

**MINUTES
BUDGET AND PERSONNEL
REGULAR MEETING
TUESDAY, AUGUST 9TH, 2022
5:30 P.M.**

THE BUDGET AND PERSONNEL COMMITTEE MET IN REGULAR SESSION IN THE COUNCIL CHAMBER AT 12 NORTH ROWE STREET, PRYOR, OKLAHOMA AT THE ABOVE DATE AND TIME.

Committee Members: _____, Choya Shropshire, Lori Siever, Randy Chitwood (alt.)

1. CALL MEETING TO ORDER.

The meeting was called to order at 5:30 p.m. by Choya Shropshire. Members present: Choya Shropshire, Lori Siever and Randy Chitwood. Members absent: none.

Others present: Dennis Nichols, Dustin Van Horn and Kemie Shropshire.

2. DISCUSS, POSSIBLY APPROVE THE MINUTES OF THE JULY 12TH, 2022, REGULAR MEETING.

Motion was made by Chitwood, second by Siever to approve the minutes of the July 12th, 2022 regular meeting. Voting yes: Shropshire and Siever. Abstaining, counting as a no vote: Chitwood. Voting no: none.

3. PETITIONS FROM THE AUDIENCE.

There were no petitions.

4. MAYOR'S REPORT.

a. Tax Reports.

Shropshire commented on the tax reports for the month.

b. Review of Financial Status.

No report.

c. General Fund Budget Review.

No report.

5. DISCUSSION AND POSSIBLE ACTION REGARDING ADDING, "EMERGENCY LEAVE SHARING TO INCLUDE SICK TIME," TO CHAPTER 13 SECTION 8 OF THE CITY OF PRYOR CREEK PERSONNEL POLICY AND PROCEDURE MANUAL.

Motion was made by Siever, second by Chitwood to approve adding, "Emergency leave sharing to include sick time," to Chapter 13 Section 8 of the City of Pryor Creek Personnel Policy and Procedure Manual. Voting yes: Siever, Chitwood, Shropshire. Voting no: none.

6. UNFORESEEABLE BUSINESS. (Any matter not reasonably foreseen prior to posting agenda.)

There was no unforeseeable business.

7. ADJOURN.

Motion was made by Siever, second by Chitwood to adjourn at 5:35 p.m. All voted yes.

Sales Tax Totals

City of Pryor Creek, OK

	2019	2020	2021	2022	2023	2024	2025
January	\$ 751,820.11	\$ 750,055.85	\$ 763,166.19	\$ 858,330.73			
February	\$ 705,422.56	\$ 747,343.85	\$ 784,577.85	\$ 965,223.87			
March	\$ 692,054.30	\$ 673,114.50	\$ 758,530.01	\$ 739,268.97			
April	\$ 707,734.29	\$ 769,552.84	\$ 805,283.96	\$ 888,320.02			
May	\$ 716,194.09	\$ 830,287.14	\$ 888,357.25	\$ 961,420.02			
June	\$ 778,619.10	\$ 931,868.08	\$ 871,739.01	\$ 844,161.50			
July	\$ 762,210.98	\$ 883,069.62	\$ 858,434.01	\$ 829,117.54			
August	\$ 772,969.72	\$ 874,325.09	\$ 815,988.59	\$ 864,954.15			
September	\$ 797,162.40	\$ 778,537.41	\$ 846,481.64	\$ 892,231.76			
October	\$ 791,341.32	\$ 743,529.37	\$ 836,959.44				
November	\$ 729,869.64	\$ 761,329.87	\$ 857,087.62				
December	\$ 752,605.85	\$ 793,356.56	\$ 828,875.55				
Total	\$8,958,004.36	\$ 9,536,370.18	\$ 9,915,481.12	\$ 7,843,028.56	\$ -	\$ -	\$ -

FISCAL YEAR

	FY 2019-2020	FY 2020-2021	FY 2021-2022	FY 2022-2023	FY 2023-2024	FY 2024-2025	FY 2025-2026
July	\$ 762,210.98	\$ 883,069.62	\$ 858,434.01	\$ 829,117.54			
August	\$ 772,969.72	\$ 874,325.09	\$ 815,988.59	\$ 864,954.15			
September	\$ 797,162.40	\$ 778,537.41	\$ 846,481.64	\$ 892,231.76			
October	\$ 791,341.32	\$ 743,529.37	\$ 836,959.44				
November	\$ 729,869.64	\$ 761,329.87	\$ 857,087.62				
December	\$ 752,605.85	\$ 793,356.56	\$ 828,875.55				
January	\$ 750,055.85	\$ 763,166.19	\$ 858,330.73				
February	\$ 747,343.85	\$ 784,577.85	\$ 965,223.87				
March	\$ 673,114.50	\$ 758,530.01	\$ 739,268.97				
April	\$ 769,552.84	\$ 805,283.96	\$ 888,320.02				
May	\$ 830,287.14	\$ 888,357.25	\$ 961,420.02				
June	\$ 931,868.08	\$ 871,739.01	\$ 844,161.50				
Total	\$ 9,308,382.17	\$ 9,705,802.19	\$ 10,300,551.96	\$ 2,586,303.45	\$ -	\$ -	\$ -



< Home

City Sales Tax Deposit Letter

- Choose a year and month, and click 'Search'.
- Results include all counties. To display a single county, enter the county.
- The past 3 years of data is available for searching. For data older than 3 years view [Archived Data](#).

For Treasurers:

Funds have been electronically transferred to your bank account, effective the date shown, for your city's tax collections received by the Oklahoma Tax Commission during the previous month.

This payment represents taxes collected during the previous month and may include interest, penalty, and delinquent remittances due from an earlier month.

If there are any questions concerning this payment, please call or write Dave Francis, (405) 522-6600, Account Maintenance Division, Oklahoma Tax Commission.

Year

Month

Entity

Effective Date	Tax, Penalty & Interest	Refunded	Suspended	Retention	Interest	Total
09-Sep-2022	896,192.24	0.00	0.00	4,480.96	520.48	892,231.76
	896,192.24	0.00	0.00	4,480.96	520.48	892,231.76

Data is updated each business day



- About
- Newsroom
- Careers
- Contact Us

Use Tax Totals

City of Pryor Creek, OK

	2019	2020	2021	2022	2023	2024	2025
January	\$ 68,525.36	\$ 128,366.65	\$ 47,239.19	\$ 163,297.12			
February	\$ 75,691.84	\$ 116,848.79	\$ 101,872.56	\$ 159,740.83			
March	\$ 82,273.50	\$ 93,213.07	\$ 70,027.53	\$ 112,038.64			
April	\$ 149,970.94	\$ 101,408.96	\$ 51,642.76	\$ 70,017.53			
May	\$ 102,655.42	\$ 81,120.35	\$ 95,247.85	\$ 76,112.48			
June	\$ 97,779.29	\$ 85,146.64	\$ 173,325.88	\$ 101,915.75			
July	\$ 139,814.46	\$ 72,780.21	\$ 68,145.11	\$ 110,868.18			
August	\$ 139,921.75	\$ 20,686.72	\$ 69,921.89	\$ 58,688.91			
September	\$ 46,037.38	\$ 61,303.56	\$ 68,791.50	\$ 87,511.99			
October	\$ 73,880.30	\$ 87,415.09	\$ 116,979.12				
November	\$ 109,959.30	\$ 85,479.26	\$ 76,090.86				
December	\$ 73,391.80	\$ 115,292.71	\$ 78,048.71				
Total	\$ 1,159,901.34	\$ 1,049,062.01	\$ 1,017,332.96	\$ 940,191.43	\$ -	\$ -	\$ -

FISCAL YEAR

	FY 2019-2020	FY 2020-2021	FY 2021-2022	FY 2022-2023	FY 2023-2024	FY 2024-2025	FY 2025-2026
July	\$ 139,814.46	\$ 72,780.21	\$ 68,145.11	\$ 110,868.18			
August	\$ 139,921.75	\$ 20,686.72	\$ 69,921.89	\$ 58,688.91			
September	\$ 46,037.38	\$ 61,303.56	\$ 68,791.50	\$ 87,511.99			
October	\$ 73,880.30	\$ 87,415.09	\$ 116,979.12				
November	\$ 109,959.30	\$ 85,479.26	\$ 76,090.86				
December	\$ 73,391.80	\$ 115,292.71	\$ 78,048.71				
January	\$ 128,366.65	\$ 47,239.19	\$ 163,297.12				
February	\$ 116,848.79	\$ 101,872.56	\$ 159,740.83				
March	\$ 93,213.07	\$ 70,027.53	\$ 112,038.64				
April	\$ 101,408.96	\$ 51,642.76	\$ 70,017.53				
May	\$ 81,120.35	\$ 95,247.85	\$ 76,112.48				
June	\$ 85,146.64	\$ 173,325.88	\$ 101,915.75				
Total	\$ 1,189,109.45	\$ 982,313.32	\$ 1,161,099.54	\$ 257,069.08	\$ -	\$ -	\$ -



< Home

City Use Tax Deposit Letter

- Choose a year and month, and click 'Search'.
- Results include all cities. To display a single city, enter the city COPO.
- The past 3 years of data is available for searching. For data older than 3 years, view [Archived Data](#)

For Treasurers:

Funds have been electronically transferred to your bank account, effective the date shown, for your city's tax collections received by the Oklahoma Tax Commission during the previous month.

This payment represents taxes collected during the previous month and may include interest, penalty, and delinquent remittances due from an earlier month.

If there are any questions concerning this payment, please call or write Dave Francis, (405) 522-6600, Account Maintenance Division, Oklahoma Tax Commission.

Year ▼

Month ▼

Entity ▼

Effective Date	Tax, Penalty & Interest	Refunded	Suspended	Retention	Interest	Total
09-Sep-2022	87,899.26	0.00	0.00	439.50	52.23	87,511.99
	87,899.26	0.00	0.00	439.50	52.23	87,511.99

Export

Data is updated each business day



Tax Commission
Follow Us

- About
- Newsroom
- Careers
- Contact Us



TOBACCO Tax Totals

City of Pryor Creek, OK

	2019	2020	2021	2022	2023	2024	2025
January	\$ 7,183.48	\$ 6,797.30	\$ 8,038.11	\$ 7,739.58			
February	\$ 4,392.65	\$ 6,340.63	\$ 5,785.89	\$ 4,945.37			
March	\$ 5,212.38	\$ 5,556.34	\$ 5,509.70	\$ 6,260.76			
April	\$ 7,092.57	\$ 9,111.80	\$ 7,684.27	\$ 5,753.23			
May	\$ 6,997.49	\$ 6,594.97	\$ 8,952.43	\$ 7,694.95			
June	\$ 7,394.72	\$ 8,343.59	\$ 7,525.81	\$ 7,196.86			
July	\$ 7,651.74	\$ 9,952.29	\$ 7,053.48	\$ 6,551.62			
August	\$ 7,002.62	\$ 8,432.39	\$ 7,836.26	\$ 4,491.53			
September	\$ 7,626.68	\$ 8,131.46	\$ 7,353.37	\$ 6,321.36			
October	\$ 6,979.41	\$ 7,502.43	\$ 6,453.01				
November	\$ 7,031.16	\$ 7,192.36	\$ 7,400.29				
December	\$ 6,403.07	\$ 7,910.53	\$ 6,894.86				
Total	\$ 80,967.97	\$ 91,866.09	\$ 86,487.48	\$ 56,955.26	\$ -	\$ -	\$ -

FISCAL YEAR

	FY 2019-2020	FY 2020-2021	FY 2021-2022	FY 2022-2023	FY 2023-2024	FY 2024-2025	FY 2025-2026
July	\$ 7,651.74	\$ 9,952.29	\$ 7,053.48	\$ 6,551.62			
August	\$ 7,002.62	\$ 8,432.39	\$ 7,836.26	\$ 4,491.53			
September	\$ 7,626.68	\$ 8,131.46	\$ 7,353.37	\$ 6,321.36			
October	\$ 6,979.41	\$ 7,502.43	\$ 6,453.01				
November	\$ 7,031.16	\$ 7,192.36	\$ 7,400.29				
December	\$ 6,403.07	\$ 7,910.53	\$ 6,894.86				
January	\$ 6,797.30	\$ 8,038.11	\$ 7,739.58				
February	\$ 6,340.63	\$ 5,785.89	\$ 4,945.37				
March	\$ 5,556.34	\$ 5,509.70	\$ 6,260.76				
April	\$ 9,111.80	\$ 7,684.27	\$ 5,753.23				
May	\$ 6,594.97	\$ 8,952.43	\$ 7,694.95				
June	\$ 8,343.59	\$ 7,525.81	\$ 7,196.86				
Total	\$ 85,439.31	\$ 92,615.87	\$ 82,582.02	\$ 17,364.51	\$ -	\$ -	\$ -



< Home

Year-To-Date Tobacco/Cig Tax

- Choose a year and month, and click 'Search'.
- Results include all COPOs. To display a single COPO, enter the COPO.
- The past 3 years of data is available for searching, For data older than 3 years view [Archived Data](#).

Fiscal Year

Entity

Search

Export

Co#	Description	Distribution Date	Amount
4909			
	Pryor	13-Sep-2022	6,321.36
			6,321.36

Data is updated each business day





(918) 783-5793
Fax: (918) 783-5786

June 13, 2022

Mayor Larry Lees
City of Pryor
P.O. Box 1167
Pryor, OK. 74362

Dear Mayor Lees:

This is to notify you in writing that Grand Gateway E.D.A./Pelivan Transit is requesting budget funding for FY- 2023 for demand response public transportation for the City of Pryor. Attached is a detailed budget for FY-2022.

Listed below is the ridership data for the City of Pryor for the Monday through Saturday demand-response transportation services:

Demand Response	FY-13	FY-14	FY-15	FY-16	FY-17	FY-18	FY-19	FY-20	FY-21
Passenger Trips	14,374	6,495	7,326	16,778	11,208	5,883	7,217	9,226	9,637
Elderly Trips	2,348	2,747	1,945	3,395	7,330	2,559	2,860	3,097	5,190
Disabled Trips	3,167	1,854	1,208	1,597	4,372	1,265	1,737	2,312	2,919

We are requesting **\$32,000** for continued support of Administration and Operational costs for a two vehicle operation to the City of Pryor for FY-23 which is a local match requirement from the grants we secure. The total budget for FY-2023 is \$224,500 and \$199,500 local match funding from federal, state, and local entities has been solicited. The City of Pryor's local match is less than 11% due to other special contracts and the OKDHS TANF rides that have benefited the city's operation in local match. Ridership in Pryor Ok, was the only service area to not see a drop in ridership during COVID-19 and has remained steady.

We again, would like to invite you and a committee to review the possibility of consolidation the CARD and Pelivan Transit transportation services together to bring more federal and state grants for transportation services to benefit the City of Pryor's operation based on ridership and revenue miles. This would be a WIN/WIN situation for all involved. We would be receptive to attending such a meeting to streamline redundant expenses currently being incurred with multiple transportation entities in Pryor and to build partnerships during these tighter funding times. This may also create extended and expanded services through this coordinated effort.

Pelivan expanded service options in the Pryor area on June 1, 2021 with the implementation of PICK Transportation. PICK Transportation is a mobility service offering on demand/curb to curb option Monday-Friday (5 PM -10 PM) and Saturdays (10 AM-2 PM) covering 21 counties in the state of Oklahoma with Pelivan acting as lead agency.

I am available to clarify any budget information and can certainly attend any meetings if needed. It is a pleasure to serve the Pryor area residents in their transportation needs.

Sincerely,



Purchase of Service Agreement

This agreement establishes a Purchase of Service Agreement made and entered into on the ____ day of _____ 2022, between the City of Pryor and Grand Gateway Economic Development Association regarding the City's financial assistance to the Association for the operation of its Pelivan Public Rural Transportation System for FY-2023.

Whereas, the City of Pryor identified certain community needs and set certain goals for the economic development of the community through its EDA Title IX Pryor Area Economic Adjustment Strategy;

And whereas, there is a need to implement programs for the City of Pryor to meet a need to provide services to attract and serve the elderly and retirees in order to become a more desirable retirement community, as well as providing a much needed service to all citizens of the community;

And whereas, the Grand Gateway Economic Development Association has a Transportation Program established under the Oklahoma Department of Transportation Section 5311 Rural Transportation Program which provides public transportation for the citizens of Pryor and has requested the City to assist in financing this program;

Grand Gateway's Pelivan Transit will assign two (2) vehicles with drivers: one vehicle for the City operation and one vehicle for the Mayes county area variable distance demand response that includes medical transportation; and one (1) dispatcher for the City of Pryor to be located at the Pelivan Transit headquarters in Big Cabin, Oklahoma, commencing **October 1, 2022 through September 30, 2023 (FY-2023)** to operate the demand-response route within the city limits, rural route (2 miles beyond City Limits and surrounding area in Mayes county from 8:00 a.m. to 4:00 p.m. Monday through Friday with the exception of Holiday's as listed below:

New Years Day
Martin Luther King, Jr. Day
Memorial Day

Labor Day
Veterans Day
Thanksgiving Day (two days)

Independence Day
Pelivan Safety Training Day

Christmas Day (two days)

City of Pryor
Purchase of Service Agreement
FY-2023
Page 2

At the end of each month, Grand gateway/Pelivan Transit will submit a report to the City of Pryor for ridership totals for the previous month based on actual ridership. The City of Pryor agrees to make one lump sum payment in the amount of \$32,000 for the entire fiscal year operation or set up monthly payments depending on their choice. Payment will be rendered beginning in October 2022.

SECTION 4. FEDERAL/STATE ASSISTANCE: The Pelivan Transit, CONTRACTOR and the City of Pryor are particularly advised that the execution and continuance of the AGREEMENT is contingent upon receipt of financial assistance from the Federal and State levels. This AGREEMENT will terminate if the Federal funding is discontinued. The State assumes no responsibility to fund this program if there is a failure of Federal funding.

The terms of this Letter of Agreement may be changed only through mutual agreement by both parties.

Edward J. Crone, Executive Dir.
Grand Gateway E.D.A
P.O. Drawer B
Big Cabin, OK. 74332

Larry Lees, Mayor, Pryor Creek
City of Pryor
P.O. Box 1167
Pryor, OK. 74362

Signed before me this _____ day
of _____, 2022

Signed before me this _____ day
of _____, 2022

Notary:

Notary:

Kendra McGeady, Pelivan Transit Director
918.244.7704

5311 Projects FY 2022		PRYOR
PELIVAN SUMMARY OF CITIES		Actual
	Rides	9,637
FY-22	Pass %	9%
	Esti miles	
CAPITAL		66,897
	Mileage %	17%
ADMINISTRATION		
	Director Salary	\$5,000.00
	Administrative Salaries	\$4,500.00
	Bookkeeper Salaries	\$1,500.00
	Fringe,total 62%	\$6,850.00
	Audit (Transit)	\$0.00
	Legal Service	\$0.00
	Travel, Administrative	\$800.00
	Advertising	\$850.00
	Subscriptions/Membership Fee	\$1,450.00
	Training Program	\$550.00
	Office furnishings	\$150.00
	Indirect Cost 30%	\$5,400.00
	Drug Testing	
	TOTAL	\$27,050.00
	Federal 80%	\$21,650.00
	Local 20%	\$5,400.00
OPERATIONAL		
	Route Supr. Salaries	\$0.00
	Dispatcher Salary	\$7,000.00
	Operations Clerk	\$3,500.00
	Drivers Salary	\$56,050.00
	Maint Mgr/Mechanic	\$3,800.00
	Mechanic Salary	\$600.00
	Fringe, total 60%	\$44,000.00
	Travel, operational	\$150.00
	Vehicle Insurance	\$16,750.00

Insurance, other		\$0.00
Office/Garage Space		\$0.00
Supplies		\$0.00
Telephone		\$1,750.00
Utilities		\$600.00
Printing		\$0.00
Postage		\$0.00
Interest Expense		\$0.00
Fuel	\$6.25 unleaded	\$36,520.00
Vehicle Maintenance, repairs		\$5,500.00
Building Maintenance, repairs		\$0.00
Equipment Maintenance, repairs		\$0.00
Indirect Cost	30%	\$34,500.00
Fees & Licensing		\$250.00
Transportation Service Agreements		0
Vehicle Service Agreement		0
Equipment Service Agreement		0
Miscellaneous		\$1,000.00
SUB-TOTAL OPERATIONAL		\$197,450.00
Less Fare Box Revenue		\$22,500.00
NET TOTAL OPERATIONAL		\$174,950.00
Federal		\$87,500.00
Local		\$87,500.00
	GRAND TOTAL	\$224,500.00
	Fed. Share	\$87,500.00
	Fares	\$22,500.00
	Local Share	\$114,500.00
	City Subsidy Fy-22	\$25,000.00
	City Subsidy FY-21	\$25,000.00
	St. Revolv	\$25,000.00
	Misc Contracts	\$15,500.00
	INCOG 5310	\$8,450.00
	DHS-Tanf Craig	\$0.00
	DHS-Tanf Delaware	\$0.00
	DHS-Tanf Mayes	\$5,000.00
	DHS-Tanf Ottawa	\$0.00

	INCOG - New Freedom	\$0.00
	INCOG - JARC	\$0.00
	Tribal Grants/Fares	\$10,500.00
	Donations/Other Grants	\$0.00
	Advertising	\$0.00
TOTAL Local Match		\$114,500.00
	% Total L.M. Met	100%
		\$0.00
Contract		
City Request		\$25,000.00
Cost per passenger		\$13.38
Cost per mile		\$1.23

Pryor Public Schools
2021-2022 Hotel/Motel Expenditure Report

Check	Check Date	To	Description	Amount
6542	2/7/2022	Lynch, Kevin	PIT Official	\$330.00
6544	2/7/2022	Puyear, Larry	PIT Official	\$110.00
6540	2/7/2022	Francis, James	PIT Official	\$220.00
6547	2/7/2022	Ragsdale, Beau	PIT Official	\$220.00
6539	2/7/2022	Meek, Harold	PIT Official	\$220.00
6546	2/7/2022	Knutson, Pete	PIT Official	\$220.00
6553	2/7/2022	Tease, Teran	PIT Official	\$220.00
6541	2/7/2022	Sheets, Joe	PIT Official	\$220.00
6554	2/7/2022	McBride, Thomas	PIT Official	\$330.00
6550	2/7/2022	Brians, Scott	PIT Official	\$110.00
6557	2/7/2022	Weary, Willie Jr.	PIT Official	\$110.00
6545	2/7/2022	Mobra, Mark	PIT Official	\$220.00
6543	2/7/2022	Wilson, Kyle	PIT Official	\$220.00
6556	2/7/2022	Corbitt, William L	PIT Official	\$110.00
6552	2/7/2022	Smith, Eliot	PIT Official	\$110.00
6538	2/7/2022	Dout, Alex	PIT Official	\$110.00
6555	2/7/2022	Fryer, Tony	PIT Official	\$220.00
6548	2/7/2022	Wilson, Ray	PIT Official	\$220.00
6537	2/7/2022	Price, Douglas	PIT Official	\$110.00
6579	2/7/2022	Snoddy, Ronald E.	PIT Official	\$110.00
6536	2/7/2022	DeVault, Mike	PIT Official	\$110.00
6551	2/7/2022	Mack, Sheldon	PIT Official	\$110.00
6566	2/9/2022	Short, Raymond	Doug Rial Tournament	\$300.00
6561	2/9/2022	Cox, Clint	Doug Rial Tournament	\$300.00
6568	2/9/2022	Dalton, Steven	Doug Rial Tournament	\$300.00
6569	2/9/2022	Pacheco, Tony	Doug Rial Tournament	\$300.00
6570	2/9/2022	Erwin, William	Doug Rial Tournament	\$300.00
6488	1/13/2022	Arbys	Hospitality Athletics	\$180.00
6617	3/21/2022	Arbys	Hospitality Athletics	\$601.25
6462	12/16/2021	Pizza Hut	Hospitality Athletics	\$209.18
6488	1/13/2022	Pizza Hut	Hospitality Athletics	\$169.49
6617	3/11/2022	Pizza Hut	Hospitality Athletics	\$107.87
6571	2/9/2022	Mid-America Grille	Hospitality Athletics	\$501.50
6617	3/11/2022	Mid-America Grille	Hospitality Athletics	\$230.00
6488	1/13/2022	Bill & Ruths	Hospitality Athletics	\$268.85
6571	2/9/2022	Bill & Ruths	Hospitality Athletics	\$510.65
6514	1/27/2022	Charlie's Chicken	Hospitality Athletics	\$1,540.58
6571	2/9/2022	JL's BBQ	Hospitality Athletics - PIT	\$1,649.00
6617	3/1/2022	Las Fuentes	Hospitality Athletics - PIT	\$1,197.60
6488	1/13/2022	Las Fuentes	Hospitality Athletics - PIT	\$679.25
6571	2/9/2022	Las Fuentes	Hospitality Athletics - PIT	\$673.37
6488	1/13/2022	Thomas Restaurant	Hospitality Athletics - PIT	\$356.54
6571	2/9/2022	Thomas Restaurant	Hospitality Athletics - PIT	\$500.44
6617	3/11/2022	Thomas Restaurant	Hospitality Athletics - PIT	\$524.00
6558	2/8/2022	Wal-Mart Stores	Hospitality Athletics	\$301.96
6603	3/8/2022	Wal-Mart Stores	Hospitality Athletics	\$269.65

Pryor Public Schools
2021-2022 Hotel/Motel Expenditure Report

6660	4/11/2022	Wal-Mart Stores	Hospitality Athletics	\$156.65
6515	1/27/2022	Homeland Supermarket	Hospitality Athletics-PIT	\$97.68
6759	5/17/2022	Arbys	Hospitality	\$262.50
6810	6/8/2022	Arbys	Hospitality	\$90.00
6759	5/17/2022	Bill & Ruths	Hospitality	\$603.60
6632	3/29/2022	Charlie's Chicken	Hospitality	\$143.10
6646	4/8/2022	Charlie's Chicken	Hospitality	\$67.60
6665	4/14/2022	Charlie's Chicken	Hospitality	\$432.59
6683	4/21/2022	Charlie's Chicken	Hospitality	\$200.70
6706	5/5/2022	Charlie's Chicken	Hospitality	\$602.10
6759	5/17/2022	Pizza Hut	Hospitality	\$404.31
6810	6/8/2022	Pizza Hut	Hospitality	\$196.14
6759	5/17/2022	Pauline's Daylight Donuts	Hospitality	\$73.00
6727	5/9/2022	Wal-Mart Stores	Hospitality	\$631.48
6800	5/31/2022	Wal-Mart Stores	Hospitality	\$284.19
6759	5/17/2022	Carl's Jr.	Hospitality	\$231.43
6759	5/17/2022	Thomas Restaurant	Hospitality	\$419.20
6810	6/8/2022	Thomas Restaurant	Hospitality	\$516.86
6700	5/5/2022	A&B Golf Shop	Hospitality Athletics	\$645.00
6700	5/5/2022	A&B Golf Shop	Hospitality Athletics	\$774.00
6700	5/5/2022	A&B Golf Shop	Hospitality Athletics	\$505.00
6759	5/17/2022	Las Fuentes	Hospitality Athletics	\$413.48
6665	4/14/2022	Charlie's Chicken	Hospitality Athletics	\$1,000.00
6810	6/8/2022	Las Fuentes	Hospitality Athletics	\$767.56
6675	4/18/2022	Bill & Ruths	Hospitality	\$181.55
6675	4/18/2022	Arbys	Hospitality	\$152.09
6593	3/3/2022	Charlie's Chicken	Hospitality	\$267.60
6675	4/18/2022	Pizza Hut	Hospitality	\$153.98
6406	11/18/2021	Arbys	Hospitality Athletics	\$107.46
6464	12/16/2021	Arbys	Hospitality Athletics	\$38.90
6336	10/8/2021	Wal-Mart Stores	Hospitality Athletics	\$47.24
6403	11/10/2021	Wal-Mart Stores	Hospitality Athletics	\$56.84
6442	12/8/2021	Wal-Mart Stores	Hospitality Athletics	\$131.68
6466	1/6/2022	Wal-Mart Stores	Hospitality Athletics	\$265.68
6826	6/17/2022	Premiere Press Graphics	Doug Rial Tournament	\$655.04
6519	1/27/2022	Premier Signs Design	PIT Tournament	\$230.00
6571	2/9/2022	Pauline's Daylight Donuts	Hospitality Athletics	\$57.00
Total				\$27,794.41

Additional funds were used throughout the year for Hospitality, additional district events and awards. If you need to see any additional receipts of amounts please let me know.

~~Current/Retired Teacher in Oklahoma~~ YES NO

Name: Joe R. W. Reed

SSN: _____

Phone: 918-902-6509

Address: 636 N 25th W PI

City: Tulsa

Zip: _____

2 Varsity Games-(2/3 man/\$55)
(Doubleheader/\$110)

Jr. Varsity Game (\$35)
Doubleheader (\$70)
Tripleheader (\$90)

Junior High 7th, 8th & 9th
\$35 per game

Mileage _____

Other (amt. _____)
\$ 115⁰⁰ Total

Joe R. W. Reed
Payment authorization signature

revised 08/06/20

Current/Retired Teacher in Oklahoma: YES NO SSN: _____ Phone: 918 407-9533

Name: Jerrin Jearce

Address: 876 E S35th N City: Tulsa Zip: 74126

2 Varsity Games - (2/3 man/\$55)
(Doubleheader/\$110)

Junior High 7th, 8th & 9th

\$35 per game

Mileage 1

Jr. Varsity Game (\$35) _____
Doubleheader (\$70) _____
Tripleheader (\$90) _____
Other (amt: _____) _____
Total \$ 110⁰⁰

Current/Retired Teacher in Oklahoma: YES _____ NO

Name: HAROLD MARK SSN _____

Phone: 918-277-4065

Address: 1625 S. 4th St City: BA

Zip: 74012

Varsity Games- (2/3 man/\$55)
 (Doubleheader/\$110)

Jr. Varsity Games (\$35)
 Doubleheader (\$70)
 Tripleheader (\$90)
 Other (amt. _____)

Junior High 7th, 8th & 9th
 \$35 per game

Mileage _____

\$ 110⁰⁰ Total

PIT

PRYOR SCHOOL'S BASKETBALL OFFICIALS PAYMENT VOUCHER

Date: 1/20/22

PLEASE FILL OUT AND RETURN TO ATHLETIC DIRECTOR

Current/Retired Teacher in Oklahoma: YES NO

Name: Beau Raybalt SSN _____

Phone: 918-671-0890

Address: 2504 S. Maple Ave. City: Broken Arrow Zip: 74012

Varsity Games- (2/3 man/\$55)

Jr. Varsity Game (\$35)

(Doubleheader/\$110)

Doubleheader (\$70)

Tripleheader (\$90)

Other (amt. _____)

Junior High 7th,8th & 9th

\$35 per game

Mileage _____

\$ 110 Total

P11

PRYOR SCHOOL'S BASKETBALL OFFICIALS PAYMENT VOUCHER Date: 1-20-22

PLEASE FILL OUT AND RETURN TO ATHLETIC DIRECTOR

Current/Retired Teacher in Oklahoma: YES NO

Name: THOMAS McBride SSN: _____ Phone: 9188796540

Address: 6259 S. Yorktown Pl. City: TULSA Zip: 74136

Varsity Games- (2/3 man/\$55) _____ Jr. Varsity Game (\$35)
 _____ (Doubleheader/\$110) _____ Doubleheader (\$70)
 _____ Tripleheader (\$90)
 _____ Other (amt. _____)

Junior High 7th,8th & 9th
 _____ \$35 per game

Mileage _____ \$ 110⁰⁰ Total

Current/Retired Teacher in Oklahoma: YES NO

Name: Pete Knutson

SSN: _____

Phone: 918 521 8491

Address: 9021 S Fulton Ave

City: Tulsa

Zip: 74137

2 Varsity Games-(2/3 man/\$55)
(Doubleheader/\$110)

- _____ Jr. Varsity Game (\$35)
- _____ Doubleheader (\$70)
- _____ Tripleheader (\$90)
- _____ Other (amt. _____)

Junior High 7th, 8th & 9th
\$35 per game

Mileage _____

\$ 110⁰⁰ Total

Current/Retired Teacher in Oklahoma: YES NO

Name: James Francis SSN: _____ Phone: 918 586 2395

Address: 1009 W Pittsburg Pl. City: Broken Arrow Zip: 74012

Varsity Games - (2/3 man/\$55) _____ Jr. Varsity Games (\$35)
_____ (Doubleheader/\$110) _____ Doubleheader (\$70)

_____ Junior High 7th, 8th & 9th _____ Tripleheader (\$90)
_____ \$35 per game _____ Other (amt. _____)

Mileage _____ \$ 110⁰⁰ Total

PIT

Current/Retired Teacher in Oklahoma: YES NO

Name: SCOTT BRIDGES SSN: _____ Phone: 918-857-6433

Address: P.O. Box 233 City: COWETA Zip: 74429

Varsity Games-(2/3 man/\$55) _____ Jr. Varsity Game (\$35)
(Doubleheader/\$110) _____ Doubleheader (\$70)

_____ Tripleheader (\$90)
_____ Other (amt. _____)

Junior High 7th,8th & 9th
_____ \$35 per game

Mileage _____ \$ 110⁰⁰ Total

Current/Retired Teacher in Oklahoma: YES NO

Current/Retired Teacher in Oklahoma: YES NO SSN.

Name: Willie Wason Jr

Phone: (918) 519-8467

Address: 2511 West Fairview St City: Tulsa

Zip: 74127

2 Varsity Games-(2/3 man/\$55)
(Doubleheader/\$110)

Jr. Varsity Game (\$35)

Doubleheader (\$70)

Tripleheader (\$90)

Other (amt.)

Junior High 7th, 8th & 9th
\$35 per game

Mileage

\$ 110⁰² Total

Current/Retired Teacher in Oklahoma: YES NO

Name: MARK MARRA

SSN: _____

Phone: 918 859 7227

Address: 9525 E 445 RD

City: Claremore

Zip: 74017

2 Varsity Games-(2/3 man/\$55)
_____ (Doubleheader/\$110)

_____ Jr. Varsity Game (\$35)
_____ Doubleheader (\$70)
_____ Tripleheader (\$90)

_____ Junior High 7th,8th & 9th
_____ \$35 per game

_____ Other (amt. _____)

Mileage _____

\$ 110⁰⁰ Total

David Hester
Payment authorization signature

revised 08/06/20

PIT

PRYOR SCHOOL'S BASKETBALL OFFICIALS PAYMENT VOUCHER

Date: 1-20-22

PLEASE FILL OUT AND RETURN TO ATHLETIC DIRECTOR

Current/Retired Teacher in Oklahoma: YES NO

Name: KEVIN LYNCH SSN: _____

Address: P.O. Box 302 City: COPAN Zip: 74022

Varsity Games- (2/3 man/\$55) _____ Jr. Varsity Game (\$35)

(Doubleheader/\$110) _____ Doubleheader (\$70)

Junior High 7th, 8th & 9th _____ Tripleheader (\$90)

\$35 per game _____ Other (amt. _____)

Mileage _____

\$ 110⁰⁰ Total

Current/Retired Teacher in Oklahoma: YES _____ NO X Phone: 919-839-2633

Name: Ryke Wilson SSN: _____

Address: 1104 Biticks St. City: LAVACA AR Zip: 72941

X Varsity Games- (2/3 man/\$55) _____ Jr. Varsity Games (\$35)
(Doubleheader/\$110) _____ Doubleheader (\$70)

_____ Tripleheader (\$90)
_____ Other (amt. _____)

Junior High 7th, 8th & 9th
_____ \$35 per game

Mileage _____

\$ 110⁰⁰ Total

PIT

PRYOR SCHOOL'S BASKETBALL OFFICIALS PAYMENT VOUCHER

Date: 1-21-22

PLEASE FILL OUT AND RETURN TO ATHLETIC DIRECTOR

Current/Retired Teacher in Oklahoma: YES NO

Name: William L. Corbett SSN:

Phone: 918-361-3551

Address: 1310 WEST XYLER ST City: TULSA

Zip: 74127

Varsity Games- (2/3 man/\$55)
(Doubleheader/\$110)

Jr. Varsity Game (\$35)
Doubleheader (\$70)
Tripleheader (\$90)
Other (amt. _____)

Junior High 7th,8th & 9th
\$35 per game

Mileage _____

\$ 110⁰⁰ Total

Current/Retired Teacher in Oklahoma: YES _____ NO

Name: Kevin Lynch SSN: _____

Phone: 918-214-3700

Address: P.O. Box 302 City: Capan

Zip: 74022

Varsity Games - (2/3 man/\$55)
(Doubleheader/\$110)

____ Jr. Varsity Games (\$35)
____ Doubleheader (\$70)
____ Tripleheader (\$90)
____ Other (amt. _____)

Junior High 7th, 8th & 9th
\$35 per game

Mileage _____

\$ 110.00 Total

Current/Retired Teacher in Oklahoma: YES NO

Name: Eliot Smith SSN: _____

Phone: 918-724-3578

Address: 2106 MARS CT City: BARTLESVILLE Zip: 74004

Varsity Games-(2/3 man/\$55)
(Doubleheader/\$110)

Jr. Varsity Game (\$35)
 Doubleheader (\$70)
 Tripleheader (\$90)
 Other (amt. _____)

Junior High 7th, 8th & 9th
\$35 per game

Mileage _____

\$ 110⁰⁰ Total

Current/Retired Teacher in Oklahoma: YES _____ NO

Name: Alex DOUT SSN _____

Phone: 918 440 4078

Address: 394180 GAP RD

City: ochelata

Zip: 74051

Varsity Games-(2/3 man/\$55)
(Doubleheader/\$110)

- Jr. Varsity Game (\$35)
- Doubleheader (\$70)
- Tripleheader (\$90)
- Other (amt. _____)

Junior High 7th,8th & 9th
\$35 per game

Mileage _____

\$ 110.⁰⁰ Total

PIT

PRYOR SCHOOL'S BASKETBALL OFFICIALS PAYMENT VOUCHER

Date: 1/21/2022

PLEASE FILL OUT AND RETURN TO ATHLETIC DIRECTOR

Current/Retired Teacher in Oklahoma: YES NO

Name: Tony Fryer SSN. _____

Phone: (918) 851-7116

Address: 69614 south 220 RD City: Wagoner

Zip: 74467

Varsity Games- (2/3 man/\$55)
 (4) (Doubleheader/\$110)

- Jr. Varsity Game (\$35)
- Doubleheader (\$70)
- Tripleheader (\$90)
- Other (amt. _____)

Junior High 7th, 8th & 9th
\$35 per game

Mileage _____

\$ 220⁰⁰ Total

Current/Retired Teacher in Oklahoma; YES

NO

Name: Thomas McBride

SSI

Phone: 918 849 2540

Address: 6259 S. Yorktown Pl.

City: Tulsa

Zip: 74136

Varsity Games - (2/3 max \$55)
(Doubleheader/\$110)

Jr. Varsity Games (\$35)

Doubleheader (\$70)

Tripleheader (\$90)

Other (amt. _____)

Junior High 7th, 8th & 9th
\$35 per game

Mileage _____

\$ 110.00 Total

Current/Retired Teacher in Oklahoma: YES _____ NO X

Name: Ray Wilson SSN _____

Phone: 918 519-0876

Address: 2539 N. Boston Pl City: Tulsa

Zip: 74106

2 Varsity Games-(2/3 man/\$55)
(Doubleheader/\$110)

_____ Jr. Varsity Game (\$35)

_____ Doubleheader (\$70)

_____ Tripleheader (\$90)

_____ Other (amt. _____)

Junior High 7th, 8th & 9th

_____ \$35 per game

Mileage _____

\$ 110⁰⁰ Total

Current/Retired Teacher in Oklahoma: YES _____ NO X

Current/Retired Teacher in Oklahoma: YES _____ NO X

Name: Kyle Wilson SSN: _____

Phone: 918-859-2633

Address: 1104 Bitticks Street City: Lavacon, Ar Zip: 72941

____ Varsity Games-(2/3 man/\$55)
✓ (Doubleheader/\$110)

____ Jr. Varsity Game (\$35)
____ Doubleheader (\$70)
____ Tripleheader (\$90)
____ Other (amt. _____)

____ Junior High 7th,8th & 9th
____ \$35 per game

Mileage _____

\$ 110⁰⁰ Total

PRYOR SCHOOL'S BASKETBALL OFFICIALS PAYMENT VOUCHER

PIT

Date: 01/22

PLEASE FILL OUT AND RETURN TO ATHLETIC DIRECTOR

Current/Retired Teacher in Oklahoma: YES NO

Name: HAROLD MARK _____ SSN _____

Address: 1625 S. 414 ST _____ City: BA _____

Phone: 918-277-4063

Zip: 74012

Varsity Games- (2/3 man/\$55)
(Doubleheader/\$110)

Jr. Varsity Game (\$35)

Doubleheader (\$70)

Tripleheader (\$90)

Other (amt. _____)

Junior High 7th, 8th & 9th
\$35 per game

Mileage _____

\$ 110 Total

Current/Retired Teacher in Oklahoma: YES NO

Current/Retired Teacher in Oklahoma: YES _____ NO

Name: MARK MOBRA SSN _____

Phone: 918 859 7227

Address: 9525 E 445 Rd City: Claremore Zip: 74017

Varsity Games - (2/3 man/\$55)
_____ (Doubleheader/\$110)

_____ Jr. Varsity Games (\$35)
_____ Doubleheader (\$70)
_____ Tripleheader (\$90)
_____ Other (amt. _____)

_____ Junior High 7th, 8th & 9th
_____ \$35 per game

Mileage _____

\$ 110⁰⁰ Total

Current/Retired Teacher in Oklahoma: YES NO

Name: Pete Knutson SSN: _____

Phone: 918 521 8491

Address: 9021 S Fulton Ave. City: Tulsa

Zip: 74137

2 Varsity Games-(2/3 man/\$55)
(Doubleheader/\$110)

____ Jr. Varsity Game (\$35)
____ Doubleheader (\$70)
____ Tripleheader (\$90)
____ Other (amt. _____)

Junior High 7th, 8th & 9th
\$35 per game

Mileage _____

\$ 110⁰⁰ Total

PIT

PRYOR SCHOOL'S BASKETBALL OFFICIALS PAYMENT VOUCHER

Date: Jan 22 2022

PLEASE FILL OUT AND RETURN TO ATHLETIC DIRECTOR

Current/Retired Teacher in Oklahoma: YES NO

Name: DOUG PRICE SSN: _____ Phone: 417.592.1642

Address: 30310 E 6TH ST City: CATOOSA Zip: 74015

Varsity Games- (2/3 man/\$55) _____ Jr. Varsity Game (\$35)
(Doubleheader/\$110) _____ Doubleheader (\$70)

Junior High 7th,8th & 9th _____ Tripleheader (\$90)
\$35 per game _____ Other (amt. _____)

Mileage _____ \$ 110 Total

Current/Retired Teacher in Oklahoma: YES _____ NO

Name: Ronald E. Snoddy

SSN: _____

Phone: 918-231-7703

Address: 10770 E 29th Pl.

City: Tulsa, Ok.

Zip: 74129

Varsity Games - (2/3 man/\$55)
(Doubleheader/\$110)

____ Jr. Varsity Games (\$35)
____ Doubleheader (\$70)
____ Tripleheader (\$90)
____ Other (amt. _____)

____ Junior High 7th, 8th & 9th
____ \$35 per game

Mileage _____

\$ 100.⁰⁰ Total

91-10

PIT

Current/Retired Teacher in Oklahoma: YES NO
Name: MIKE DeVault SSN _____

Address: 4108 W JACKSON ST City: B.A.
Varsity Games-(2/3 man/\$55)
(Doubleheader/\$110)

Junior High 7th,8th & 9th
\$35 per game
Mileage _____

Phone: 918 630 0851
Zip: 74012
Jr. Varsity Game (\$35)
Doubleheader (\$70)
Tripleheader (\$90)
Other (amt. _____)
\$ 100.⁰⁰ Total

Employed teacher in Oklahoma: YES _____ NO SSA

Name: Thomas McBride

Phone: 9188996540

Address: 6259 S. Yorktown Pl. City: Tulsa

Zip: 74136

Varsity Games-(2/3 man/\$55)
(Doubleheader/\$110)

____ Jr. Varsity Game (\$35)
____ Doubleheader (\$70)
____ Tripleheader (\$90)
____ Other (amt. _____)

____ Junior High 7th, 8th & 9th
____ \$35 per game

Mileage _____

\$ 100.00 Total

Current/Retired Teacher in Oklahoma: YES NO

Name: Sheldon Mack SSN: _____

Phone: (918) 644-1112

Address: 2613 E 29th St. N. City: Tulsa

Zip: 74110

Jr. Varsity Game (\$35)

Doubleheader (\$70)

Tripleheader (\$90)

Varsity Games-(2/3 man/\$55)

(Doubleheader/\$110)

Other (amt. _____)

Junior High 7th,8th & 9th

\$35 per game

Mileage _____

\$ 110 Total

Daryl Heston
Payment authorization signature

revised 08/06/20

PRYOR SCHOOL'S BASKETBALL OFFICIALS PAYMENT VOUCHER

Date: 1-24-22

PIT

PLEASE FILL OUT AND RETURN TO ATHLETIC DIRECTOR

Current/Retired Teacher in Oklahoma: YES NO SSN: _____ Phone: 918-902-6509

Name: Joe Sheels City: Tulsa, OK
Address: 636 N 88th W PI Zip: 74127
Varsity Games - (2/3 man/\$55) _____ Jr. Varsity Game (\$35) _____
(Doubleheader/\$110) _____ Doubleheader (\$70) _____
_____ Tripleheader (\$90) _____
_____ Other (amt. _____)

Junior High 7th, 8th & 9th
\$35 per game

Total \$ 110.00

Milazna

Current/Retired Teacher in Oklahoma: YES NO

SSN: _____

Phone: 918 407-9532

Name: Jean Year 2

City: Tulsa

Zip: 74126

Address: 676 E 53rd N
Varsity Games - (2/3 man/\$55)
(Doubleheader/\$110)

- _____ Jr. Varsity Games (\$35)
- _____ Doubleheader (\$70)
- _____ Tripleheader (\$90)
- _____ Other (amt. _____)

Junior High 7th, 8th & 9th
\$35 per game

Mileage _____

\$ ~~100.00~~ Total

PIT

PRYOR SCHOOL'S BASKETBALL OFFICIALS PAYMENT VOUCHER

Date: 1-27-22

Current/Retired Teacher in Oklahoma: YES _____ NO

Name: Ray Wilson SSN: _____ Phone: 918 514-0676

Address: 2539 N. Boston Pl City: TULSA Zip: 74102

2 Varsity Games-(2/3 man/\$55) _____ Jr. Varsity Game (\$35)
 _____ (Doubleheader/\$110) _____ Doubleheader (\$70)
 _____ Tripleheader (\$90)
 _____ Other (amt. _____)

Junior High 7th, 8th & 9th
 \$35 per game

Mileage _____ \$ ~~100~~ 110 Total

Current/Retired Teacher in Oklahoma: YES _____ NO

Name: Beau Ragdale SSN: _____

Phone: 918-671-0890

Address: 2804 S. Maple Ave

City: Broken Arrow

Zip: 74012

Varsity Games-(2/3 man/\$55)
 (Doubleheader/\$110)

Jr. Varsity Game (\$35)
 Doubleheader (\$70)
 Tripleheader (\$90)
 Other (amt. _____)

Junior High 7th,8th & 9th
 \$35 per game

Mileage _____

\$ ~~100.00~~ 110.00 Total

Current/Retired Teacher in Oklahoma: YES NO

Name: James Francis SSN: _____

Phone: 918 586 2395

Address: 1009 W Pittsburg Pl. City: Broken Arrow

Zip: 74012

Varsity Games-(2/3 man/\$55)
(Doubleheader/\$110)

____ Jr. Varsity Game (\$35)
____ Doubleheader (\$70)
____ Tripleheader (\$90)

____ Junior High 7th, 8th & 9th
\$35 per game

____ Other (amt. _____)

Daryl Heston Mileage _____
Payment authorization signature

\$ 110.00 Total

revised 08/06/20

PRYOR SCHOOL'S BASKETBALL OFFICIALS PAYMENT VOUCHER

PIT

Date: 1-22-22

PLEASE FILL OUT AND RETURN TO ATHLETIC DIRECTOR

Current/Retired Teacher in Oklahoma: YES NO

Name: LARRY PUYEAR

SSN: _____

Phone: 918-378-9690

Address: 16408 E 48TH ST

City: TULSA

Zip: 74134

Varsity Games- (2/3 man/\$55)
(Doubleheader/\$110)

- Jr. Varsity Game (\$35)
- Doubleheader (\$70)
- Tripleheader (\$90)
- Other (amt. _____)

Junior High 7th,8th & 9th
\$35 per game

Mileage _____

\$ 110 Total

Current/Retired Teacher in Oklahoma: YES _____ NO

Name: Kevin Lynch SSN. _____

Phone: 918-214-3700

Address: P.O. Box 302 City: Copan

Zip: 74022

Varsity Games - (2/3 man/\$55)
(Doubleheader/\$110)

- _____ Jr. Varsity Games (\$35)
- _____ Doubleheader (\$70)
- _____ Tripleheader (\$90)
- _____ Other (amt. _____)

_____ Junior High 7th, 8th & 9th
\$35 per game

Mileage _____

\$ 110 Total

Current/Retired Teacher in Oklahoma: YES _____ NO _____

Current/Retired Teacher in Oklahoma: YES NO

Name: CITAB SIMON

SSN: _____

Phone: 918-264-9332

Address: 1107 E. Grandstaff, Lot #1 City: Cushing

Zip: 74023

JH/HS Due \$140.00

JH Quad \$190.00

HS Quad : \$240.00

JH Tour \$225.00

HS Tournament \$450.00

Other (amt. _____)

HS - 1 Day Pool Tournament
\$300

HS Tour (1-day) \$275.00

\$ 300⁰⁰ Total

Daryl Simon

Payment authorization signature

revised 08/06/2020

PRYOR SCHOOL'S WRESTLING OFFICIALS PAYMENT VOUCHER

DATE 1-28-22

PLEASE FILL OUT AND RETURN TO ATHLETIC DIRECTOR

Current/Retired Teacher in Oklahoma: YES NO

Phone: 918 202200

Name: CLINT COX

SSN: _____

Zip: 74010

Address: 416 E Gth AVE

City: BASTOW

<input type="checkbox"/> JH/HS Duz \$140.00	<input type="checkbox"/> JH Quad \$190.00	<input type="checkbox"/> HS Qaud (\$240.00
<input type="checkbox"/> JH Tourn \$225.00	<input type="checkbox"/> HS Tournament \$450.00	<input type="checkbox"/> Other (amt. _____)
<input checked="" type="checkbox"/> HS - 1 DAY Pool Tourn # 300	<input type="checkbox"/> HS Tour (1-day) \$275.00	\$ <u>300⁰⁰</u> Total <u>Girls</u>

Current/Retired Teacher in Oklahoma: YES _____ NO

Name: STEVE DALTON

SSN: _____

Phone: 918 706-6890

Address: 14549 Hectonville Rd

City: Mounds

Zip: 74047

JH/HS Due \$140.00

JH Quad \$190.00

HS Qaud (: \$240.00

JH Tour \$225.00

HS Tournament \$450.00

Other (amt. _____)

HS-1 Day Pool Tour. \$300

HS Tour (1-day) \$275.00

\$ 300⁰⁰ Total

Current/Retired Teacher in Oklahoma: YES NO

Name: Tony Pacheco

SSN

Phone: 918-760-5110

Address: 4136 S. 31 West Avenue

City: Tulsa

Zip: 74107

JH/HS Due \$140.00

JH Quad \$190.00

HS Quad (\$240.00

JH Tour \$225.00

HS Tournament \$450.00

Other (amt. _____)

~~HS 1-DAY Pool Tourna.~~
\$ 300

HS Tour (1-day) \$275.00

\$ 300⁰⁰ Total

Current/Retired Teacher in Oklahoma: YES NO

Name: BILLERWIN SSN: _____ Phone: 918-367-774

Address: 1207 E 137TH ST City: Glenpool Zip: 74033

JH/HS Dual \$140.00 JH Quad \$190.00 HS Quad (\$240.00

JH Tour \$225.00 HS Tournament \$450.00 Other (amt. _____)

HS 1-DAY Pool Tour. HS Tour (1-day) \$275.00 \$ 300⁰⁰ Total

\$300

PRYOR SCHOOL'S WRESTLING OFFICIALS PAYMENT VOUCHER

DATE 1/28/22

PLEASE FILL OUT AND RETURN TO ATHLETIC DIRECTOR

Current/Retired Teacher in Oklahoma: YES NO

Name: Paul Ameen SSN _____ Phone: 918-230-8976

Address: 6781 FOXBRIAN DRIVE City: Tulsa Zip: 74132

<input type="checkbox"/> JH/HS Dual \$140.00	<input type="checkbox"/> JH Quad \$190.00	<input type="checkbox"/> HS Quad (\$240.00
<input type="checkbox"/> JH Tourn \$225.00	<input type="checkbox"/> HS Tournament \$450.00	<input type="checkbox"/> Other (amt. _____)
<input checked="" type="checkbox"/> HS-1 DAY Pool Tourn. \$300	<input type="checkbox"/> HS Tour (1-day) \$275.00	\$ <u>300⁰⁰</u> Total

PO # 60220448

PAULIES DAYLIGHT DONUTS
319 S MILL ST
PRYOR, OK 74361
9183738000

Merchant ID: 0516
Term #: 0001

6571
2-9-22
Store #: 5611
Ref #: 0029

Sale

XXXXXXXXXXXX9747

VISA

Entry Method: Chip

Amount: \$

57.00

Tip:

Total:

Paul Donald

01/21/22

08:08:12

Inv #: 000020

Appr Code: 060483

Transaction ID: 302021500929527

Apprvd: OnLine

Batch#: 000528

VISA CREDIT

AID: A0000000031010

TSI: 6800

TVR: 800008000

Customer Copy

THANK YOU

60220651



Restaurant 1101673

201 S. Mill
Pryor, OK 74361

3/31/2022 11:36:10 AM
Order 335553 Cashier: JENNIFER B

15 Famous Ch	77.85
15 Western	89.85
10% Senior Disc	- 16.77
SubTotal	150.93
Tax	0.00
Tax exempt ID	736032624
Total	150.93
Credit Cards	150.93

Drive Thru
Thank you for visiting!
Customer Copy

Pam Donald

60220651

6759



Restaurant 1101673

201 S. Mill
Pryor, OK 74361

3/31/2022 11:35:30 AM
Order 335552 Cashier: JENNIFER B

8 Famous Ch	41.52
Western	47.92
10% Senior Disc	- 8.94
SubTotal	80.50
Tax	0.00
Tax exempt ID	736031624
Total	80.50
Credit Cards	80.50

Drive Thru
Thank you for visiting!
Customer Copy

Pam Donald

60220651

6759
5-17-22



Restaurant 1101673

201 S. Mill
Pryor, OK 74361

4/14/2022 10:59:27 AM
Order 336912 Cashier: JENNIFER B

15 Famous Ch	77.85
15 Western	89.85
10% Senior Disc	16.77
SubTotal	150.93
Tax	0.00
Tax exempt ID	661460
Total	150.93
Credit Cards	150.93

Ticket #0

0014 Server: REYNA B (#10) Rec: 13
04/28/22 08:35, Chip T: 118 Term: 2

Thomas Restaurant
215 S. Mill Street
Pryor, OK 74361
(918)824-4700

Name: FUND_TRAVEL_2/ACTIVITY
TID 775813300002

Purchase
VISA CREDIT XXXXXXXXXXXX9747
CVM SIGN
Invoice 0001417824
Response APPROVED
Auth Code 011656

EMV DETAILS
MODE CHIP
AID A0000000031010
TVR 8080008000
IAD 06010A03A00000
TSI 6800
ARC Z3
Amount USD \$283.54

Chk Total: 283.54

Tip: _____

Total: _____

Duplicate *20# 60220702*
top copy -> customer
Suggested Gratuity
15 PERCENT 42.53
18 PERCENT 51.04
20 PERCENT 56.71

Customer Copy

Daryl Heitm

0026 Server: GABRIELA E (#6) Rec: 19
04/29/22 08:55, Chip T: 814 Term: 2

Thomas Restaurant
215 S. Mill Street
Pryor, OK 74361
(918)824-4700

Name: FUND_TRAVEL_2/ACTIVITY
TID 775813300002

Purchase
VISA CREDIT XXXXXXXXXXXX9747
CVM SIGN
Invoice 0002619205
Response APPROVED
Auth Code 082625

EMV DETAILS
MODE CHIP
AID A0000000031010
TVR 8080008000
IAD 06010A03A08000
TSI 6800
ARC Z3
Amount USD \$278.32

Chk Total: 278.32

Tip: _____

Total: _____

Duplicate *20# 60220702*
top copy -> customer
Suggested Gratuity
15 PERCENT 41.75
18 PERCENT 50.10
20 PERCENT 55.66

Customer Copy

Tom Donald

Tom Donald

Customer Copy

Duplicate
top copy -> customer
Suggested Gratuity
15 PERCENT 57.23
18 PERCENT 68.67
20 PERCENT 76.30

Chk Total: 419.20
Tip: _____
Total: 419.20

EMV DETAILS
MODE CHIP
AID A0000000031010
TVR 8080008000
IAD 06010A03A00000
TSI 6800
ARC Z3
Amount USD \$419.20

Name: FUND_TRAVEL_2/ACTIVITY
TID 775813280001
Purchase
VISA CREDIT XXXXXXXXXXXX9747
CVM SIGN
Invoice 0006596814
Response APPROVED
Auth Code 044601

0066 Server: VICTOR O (#37) Rec: 52
04/07/22 13:18, Chip T: 101 Term: 1
Thomas Restaurant
215 S. Mill Street
Pryor, OK 74361
(918)824-4700
6-17-2022

6810

6810

6-17-2022

6700
5-5-22

A & B Golf Shop

For All Your Golfing Needs!

724 E 530
Pryor, Ok. 74361
Phone (918) 825-3056 Fax (918) 825-7347

DATE: April 28, 2022
INVOICE # 4282022

Bill To: Pryor High School
Atten: Coach Greg Arnold

Pryor, OK 74361

Ship To:

Comments or Special Instructions: Boys

SALESPERSON	P.O. NUMBER	SHIP DATE	SHIP VIA	F.O.B. POINT	TERMS
					Net 30

QUANTITY	DESCRIPTION	UNIT PRICE	AMOUNT
90	Lunch Meals	\$ 5.50	\$ 495.00
15	Range Balls for a team	\$ 10.00	\$ 150.00

SUBTOTAL	\$ 645.00
TAX RATE	0.00%
SALES TAX	-
SHIPPING & HANDLING	-
TOTAL	\$ 645.00

Make all checks payable to A & B Golf Shop
If you have any questions concerning this invoice, contact Dennis Bowman, 825-3056, pryorgolfpro@sbcglobal.net

THANK YOU FOR YOUR BUSINESS!

6700
5522

A & B Golf Shop

For All Your Golfing Needs!

724 E 530
Pryor, Ok. 74361
Phone (918) 825-3056 Fax (918) 825-7347

DATE: April 19, 2022
INVOICE # 4192022

Bill To: Pryor High School
Atten: Coach Greg Arnold

Pryor, OK 74361

Ship To:

Comments or Special Instructions: Girls April 21,2022

SALESPERSON	P.O. NUMBER	SHIP DATE	SHIP VIA	F.O.B. POINT	TERMS
	60220746				Net 30

QUANTITY	DESCRIPTION	UNIT PRICE	AMOUNT
108	Lunch Meals	\$ 5.50	\$ 594.00
18	Range Balls for a team	\$ 10.00	\$ 180.00

SUBTOTAL	\$ 774.00
TAX RATE	0.00%
SALES TAX	-
SHIPPING & HANDLING	-
TOTAL	\$ 774.00

Make all checks payable to A & B Golf Shop
If you have any questions concerning this invoice, contact Dennis Bowman, 825-3056, pryorgolfpro@sbcglobal.net

THANK YOU FOR YOUR BUSINESS!

6700
5-5-22

A & B Golf Shop

For All Your Golfing Needs!

724 E 530
Pryor, Ok. 74361
Phone (918) 825-3056 Fax (918) 825-7347

DATE: April 21, 2022
INVOICE # 4212022

Bill To: Pryor High School
Atten: Coach Greg Arnold

Pryor, OK 74361

Ship To:

Comments or Special Instructions: Jr. High April 21th,

SALESPERSON	P.O. NUMBER	SHIP DATE	SHIP VIA	F.O.B. POINT	TERMS
	60220747				Net 30

QUANTITY	DESCRIPTION	UNIT PRICE	AMOUNT
70	Lunch Meals	\$ 5.50	\$ 385.00
12	Range Balls for a team	\$ 10.00	\$ 120.00

SUBTOTAL	\$ 505.00
TAX RATE	0.00%
SALES TAX	-
SHIPPING & HANDLING	-
TOTAL	\$ 505.00

Make all checks payable to A & B Golf Shop
If you have any questions concerning this invoice, contact Dennis Bowman, 825-3056, pryorgolfpro@sbcglobal.net

THANK YOU FOR YOUR BUSINESS!

LAS FUENTES MEXICAN REST
110 S MILL ST
PRYOR, OK 74361
918-824-1303
CT2-2000536802

04/07/2022 12:29

Sale

Trans #: 34 Batch #: 26

VISA CHIP
*****9747 **/**

BASE AMT: \$399.50
SUC: \$13.98
DISC: \$0.00

SUB TOTAL: \$413.48

TIP AMT: \$-----

TOTAL AMT: \$-----

Resp: APPROVAL 072864
Code: 072864
Ref #: 209718003901
TransID: 382097666341737

App Name: VISA CREDIT
AID: A0000000031010
TUR: 8080008000
TSI: 6800

THANK YOU
COME AGAIN!
CUSTOMER COPY



It's just that good!

S. Hill • PRYOR, OK 74361 • (918) 825-5825 • Fax: (918) 825-9229 • Email: foanial39@aol.com

Telexes

1481

4/14/22 INVOICE

DATE: 4-12-2022

SOLD TO		SHIP TO		OUR ORDER NO.			
CUST. ORDER NO.	DATE SHIPPED	SHIPPED VIA	TERMS	SALESMAN	F.O.B.	UNIT PRICE	AMOUNT
Fryer High School		Pam Arnold		Thank you!			884.50
Track Meet PO# 60220764		Pam Arnold		We Appreciate Your business!			199.68
Daryl [Signature]		Ribs (8oz)					53.91
		Wedges (5)					
		Rolls (1)					
		Boxed - BBQ Sauce - Utensils					
							1098.09
							No tax
							1098.09

Thank You

darah hunt
 Give us feedback @ survey.walmart.com
 Thank you! ID #:7QCSMZ7JNY



918-825-6000 Mgr:PHILLIP
 4901 S MILL ST
 PRYOR OK 74361

ST# 00022	OP# 000131	TE# 03	TR# 04562	
MLO SWT T GL	009147504189	F	2.86	0 0
MLO SWT T GL	009147504189	F	2.86	0 0
MLO SWT T GL	009147504189	F	2.86	0 0
UNSWEET TEA	009147540799	F	2.86	0 0
UNSWEET TEA	009147540799	F	2.86	0 0
LATCH BOXES	007314909733			
4 AT 1 FOR	12.48		49.92	0
FRST CKIE	007874232212	F	5.94	0
DBLCHOCCKS	007874236799	F	2.87	0
DBLCHOCCKS	007874236799	F	2.87	0
MM COOKIE	007874236798	F	2.87	0
MM COOKIE	007874236798	F	2.87	0
CC COOKIES	007874209234	F	2.87	0
CC COOKIES	007874209234	F	2.87	0
OR COOKIES	007874214833	F	2.87	0
OR COOKIES	007874214833	F	2.87	0
LVS TWN LEM	001920099041		4.97	0 0
SOFTSOAP	007418244571		1.98	0
SOFTSOAP	007418244571		1.98	0

SUBTOTAL 102.05
 TOTAL 102.05
 WALMART CREDIT TEND 102.05

WALMART CREDIT **** **** **** 1705 I 1
 APPROVAL # 790696
 REF # 1042000314
 TRANS ID - 161210479790696
 VALIDATION -
 PAYMENT SERVICE -
 AID A000000817001001
 TC DBAA9E48786A3E52
 TERMINAL # SC010751
 *NO SIGNATURE REQUIRED

07/29/21 08:19:39
 CHANGE DUE 0.00
 # ITEMS SOLD 21

TC# 2042 4092 5034 0250 4140 4



07/29/21 08:19:53
 CUSTOMER COPY

Give us feedback @ survey.walmart.com
 Thank you! ID #:7QD1FX7MD9

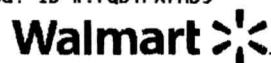

918-825-6000 Mgr:PHILLIP
 4901 S MILL ST
 PRYOR OK 74361

ST# 00022	OP# 007131	TE# 03	TR# 07177	
MLO SWT T GL	009147504189	F	2.86	0 0
MLO SWT T GL	009147504189	F	2.86	0 0
MLO SWT T GL	009147504189	F	2.86	0 0
UNSWEET TEA	009147540799	F	2.86	0 0
SC 100Z 15PK	068113178113	F		
4 AT 1 FOR	2.00		8.00	0

SUBTOTAL 19.44
 TOTAL 19.44
 WALMART CREDIT TEND 19.44

WALMART CREDIT **** **** **** 1705 I 1
 APPROVAL # 973927

REF # 1042000314
 TRANS ID 361210467973927

VALIDATION -
 PAYMENT SERVICE -
 AID A000000817001001
 TC 752DB717C90124

TERMINAL # SC010751
 *NO SIGNATURE REQUIRED
 08/04/21 08:00:02
 CHANGE DUE 0.00
 # ITEMS SOLD 8

TC# 3189 6388 6376 8262 4797



08/04/21 08:00:16
 CUSTOMER COPY

darah hunt



TC# 3505 7581 0521 2369 4760 5
 *** MEMBER COPY ***

ITEMS SOLD 12

Visit samclub.com to see your savings

Sam's Instant Savings: \$18.00

Additional Savings This Trip:

Change Due 0.00

AID A000000817001001
 TC 44E9E067FD2510D4
 TERMINAL # SC010270
 *NO SIGNATURE REQUIRED

WALMART CREDIT TEND 149.76
 WALMART CREDIT **** **** **** 1705 I 1
 APPROVAL # 410627

V INST SV 2 8 4.00-
 BOUNTY SAS 10.00-N
 8" FOAM PLT 8.00-N
 SUBTOTAL 149.76

VL	980271543	KLNX ULTRA	14.98
I	980271543	KLNX ULTRA	14.98
I	980304706	BOUNTY SAS	14.98
I	980304706	BOUNTY SAS	19.98
I	980261983	NAPPINS	19.98
I	980261983	NAPPINS	7.98
I	980244621	RED CUP 180	9.48
I	877179	12 OZ CUP	15.48
I	361387	8" FOAM PLT	12.98
I	361387	8" FOAM PLT	12.98
I	916191	ZPLC STRG G	15.98
I	916191	ZPLC STRG G	15.98
I	916191	ZPLC STRG G	15.98
I	916191	ZPLC STRG G	15.98

07/28/21 09:46 8952 06238 004 1291
 PRYOR

darah hunt
 SAM'S CLUB
 CLUB MANAGER WESLEY SMITH
 (918) 212-7037
 10#00220010

BILL & RUTHS SUB SHOP
 310 S MILL ST
 PRYOR OK 74361
 918-825-1009

****REPRINT****

Terminal ID: *****075 ***3

2/28/22 4:15 PM

VISA - MANUAL

ACT #: *****9747

CREDIT SALE

UID: 205926312354 REF #: 7989

BATCH #: 987 AUTH #: 086113

AMOUNT \$181.55

TIP \$ _____

TOTAL \$ _____

APPROVED
 CUSTOMER COPY

GUEST CHECK™

Date	Table	Guests	Server
2/28/22			Paul Pryor

APPT-SOUP/SAL-ENTREE-VEG/POT-DESSERT-BEY

Burdit Contea

2xley mix cutn Half

wrapeel Seperate

2/28/22

Tom Arnold

12:30 Tax
 Total

Thank You — Please Come Again

MONOGRAM G6000-MGRM reorder #122319 MADE IN THE USA

BILL AND RUTH
 310 S MILL ST
 PRYOR OK 74361
 918-825-1009

APPLICABLE TAXES:
 SALES TAX 17.95
 10% 17.95
 %- 17.95
 1 Misc Item 11 11.00
 21 N

TAX \$181.80
 TX1 \$17.73
 L \$181.55
 CREDIT \$181.55

6675

RBA 01418-OK-Pryor

Restaurant #01418
315 S Mill
Pryor, OK 74361
Phone 918-825-3192

2/26/2012 1:07:13 PM
Order Id: 8A00CKNNAEBR
school - Carry Out
Employee: Register 200
Total Items: 40

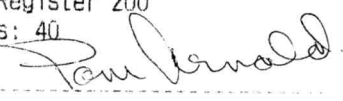

school

10 CPN - 2/\$6 Everyday Value (@6)	\$60.00
20 RB Classic	
20 BnC Classic (@4.69)	\$93.80
Sub Total	\$153.80
10% Off	-\$15.38
SALES TAX	\$13.67
Order Total	\$152.09
Visa	\$152.09
AUTHORIZED AMOUNT	\$152.09
Card#: *****9747	
Authorization: 018737	

AID: A0000000031010

--> Order Closed <--

We would love your feedback!
Visit arbys.com/feedback
Join our team!
Text RBA to 97211

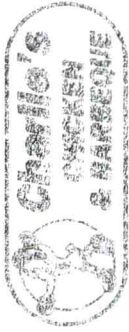

It's just that good!

34 S. MH • PRYOR, OK 74361 • (918) 225-8655 • Fax (918) 225-9228 • Email: fountain38@aol.com

1441

INVOICE

DATE: 8-22-2020

SOLD TO		SHIP TO		SALESMAN		OUR ORDER NO.	
Pryor High School		Pam Arnold		PO# 60220588		Thank you! We appreciate your business!	
CUST. ORDER NO.	DATE SHIPPED	SHIPPED VIA	TERMS	FOB			
QTY. ORDERED	B/O	QTY. SHIPPED	DESCRIPTION		UNIT PRICE	AMOUNT	
		40	Chunks & wedges Roll			267.60	
						No tax	
						<u>267.60</u>	

Pam Arnold

Thank You

PRYOR PUBLIC SCHOOLS
1100 SE 9TH ST
BURDICK CENTER
PRYOR OK 74361

(918)373-1035

BY: F-06

ADD \$7 TIP

01	1	Large Pan Cheese Beef	17.18
02	1	Large Pan Cheese Ham	17.18
03	1	Large Thin Cheese Pepperoni	16.18
04	1	Large Thin Cheese Park	16.18
05		Small Bone Out Medium	18.00
06	2	Small Bone Out Medium	12.00

COUPON (F7, F7, F7, F	24.72
Subtotal	72.00
Delivery Charge	3.99
SALLES TAX	0.00
Balance Due	75.99
Amt Tendered	
Credit Card	75.99
Amt Due	0.00

Driver gratuity
not included

EARN FREE PIZZA
WITH HUT REWARDS
ANY WAY YOU ORDER

Restrictions Apply

Join Hut Rewards for free at
PizzaHut.com/Rewards

HOW DID WE DO?

CODE: 51nf 1mr4 m20

We're always improving our pizza game!

PARTY ON THE BACK (TURN ME OVER)

PARTY ON THE BACK (TURN ME OVER)

PARTY ON THE BACK (TURN ME OVER)

PARTY ON THE BACK (TURN ME OVER)

PRYOR PUBLIC SCHOOLS
1100 SE 9TH ST
BURDICK CENTER
PRYOR OK 74361

(918)373-1035

BY: F-06

ADD \$7 TIP

01	1	Large Pan Cheese Beef	17.18
02	1	Large Pan Cheese Pork	17.18
03	1	Large Thin Cheese Beef	16.18
04	1	Large Thin Cheese	16.18
05	3	Small Bone Out Medium	18.00

COUPON (F7, F7, F7, F	24.72
Subtotal	60.00
Delivery Charge	3.99
SALLES TAX	0.00
Balance Due	63.99
Amt Tendered	
Credit Card	63.99
Amt Due	0.00

Driver gratuity
not included

EARN FREE PIZZA
WITH HUT REWARDS
ANY WAY YOU ORDER

Restrictions Apply

Join Hut Rewards for free at
PizzaHut.com/Rewards

HOW DID WE DO?

CODE: 51nf mpfe c6j

We're always improving our pizza game!

Enter the code above to tell us about
your experience at

(TURN ME OVER)

PARTY ON THE BACK (TURN ME OVER)

PARTY ON THE BACK (TURN ME OVER)

PARTY ON THE BACK (TURN ME OVER)

Tom Arnold

Tom Arnold

6462
12-16-21

RBA-01418-OK-Pryor

Restaurant #01418
315 S Mill
Pryor, OK 74361
Phone 918-825-3192

11/15/2021 5:13:51 PM
Order # 1441F
DT357
Employee # 40
Total \$ 20

DT 357

Sub Total \$50.90
Open \$ Amount -\$40.00
SALES TAX \$1.98
Order Total \$18.90
Visa AUTHORIZED AMOUNT \$38.90
Card# *****9747
Authorization: 092616

Signature
--> Order Closed <--

We would love your feedback!
Visit us at arbys.com/feedback
to join our team!
Call RBA to 211

Sub Total
SALES TAX
Order Total
Visa AUTHORIZED AMOUNT
Card#: *****9747
Authorization: 028729
AID: A000000031010

Signature
--> Order Closed <--

WE MAKE IT RIGHT
Comments, questions or information
www.arbys.com/contact-us/
PH: 1 800 599 2729

RBA-01418-OK-Pryor

Restaurant #01418
315 S Mill
Pryor, OK 74361
Phone 918-825-3192

10/7/2021 11:39:28 AM
Order Id: AAC8CKDNAEAF
teachersGreg - Eat In
Employee: Register 200
Total Items: 20

teachersGreg

10 CPN - 2/\$6-Everyday Value (06) \$60.00
20 BnC Classic

Sub Total \$50.00
Open \$ Amount -\$40.00
SALES TAX \$1.98
Order Total \$21.98
Visa AUTHORIZED AMOUNT \$21.98
Card#: *****9747
Authorization: 078615

Signature
AID: A000000031010
--> Order Closed <--

WE MAKE IT RIGHT
Comments, questions or information?
www.arbys.com/contact-us/
PH: 1 800 599 2729

10/6/2021 11:35
Order Id: AAC8CKDNAEAF
COACH ARNOLDG - Carry Out
Employee: Register 200
Total Items: 20
SP# 60320052

COACH ARNOLDG

RBA-01418-OK-Pryor

Restaurant #01418
315 S Mill
Pryor, OK 74361
Phone 918-825-3192

6464
11-18-20

PO#

Give us feedback @ survey.walmart.com
Thank you! ID #:7QDQ847FZK

Walmart * 6403

918-825-6000 Mgr:PHILLIP 11-10-21

ST# 00022	OP# 007023	TE# 05	TR# 01977	
MULTIPACK	002840015586	F	11.76	0
OATML CREME	002430004101	F	2.00	0
OATML CREME	002430004101	F	2.00	0
SNACK CAKE	002430004101	F	3.68	0
SNACK CAKE	002430004101	F	3.68	0
DR PEPPER	007800008310	F	9.78	0
DR PEPPER	007800008210	F	9.78	0
DR PEPPER	004900001063	F	9.78	0
DR PEPPER	007874227909	F	4.38	0
SUBTOTAL				56.84
TOTAL				56.84

WALMART CREDIT TEND
WALMART CREDIT **** * 2984 1 1
APPROVAL # 471051
REF # 1042000314
TRANS ID 881277656471051
VALIDATION -
PAYMENT SERVICE -
AID A000000817001001
TC 1RCC8C23BAF1955A
TERMINAL # SC010912
*NO SIGNATURE REQUIRED

[Handwritten Signature]

CHANGE DUE 13:14:06 0.00
ITEMS SOLD 9
TC# 2998 2462 4127 3656



10/04/21 13:14:21
***CUSTOMER COPY**

PO# 60220053 ✓

Give us feedback @ survey.walmart.com
Thank you! ID #:7QDDWP76MS

Walmart * 6336 10-8-2021

918-825-6000 Mgr:PHILLIP

ST# 00022	OP# 008321	TE# 01	TR# 02604	
GV .5L WATER	007874227909	F	4.38	0
GV .5L WATER	007874227909	F	4.38	0
GZ FRTPN12PK	005200004428	F	6.28	0
GZ FRTPN12PK	005200004428	F	6.28	0
GATORADE	005200004338	F	6.48	0
GATORADE	005200004338	F	6.48	0
G2 12PK GF	005200012251	F	6.48	0
G2 12PK GF	005200012251	F	6.48	0
SUBTOTAL				47.24
TOTAL				47.24

WALMART CREDIT TEND
WALMART CREDIT **** * 2984 1 1
APPROVAL # 826132
REF # 1042000314
TRANS ID - 711257660826132
VALIDATION -
PAYMENT SERVICE -
AID A000000817001001
TC 049C4202032A4153
TERMINAL # SC010270
*NO SIGNATURE REQUIRED

Home FB Officials

09/14/21 13:21:23
CHANGE DUE 0.00
ITEMS SOLD 8
TC# 3732 0459 0040 2300 2474



09/14/21 13:21:45
***CUSTOMER COPY**

Pam Arnold

Pam Arnold



11/15/21 13:25:07
***CUSTOMER COPY**

WALMART CREDIT TEND
WALMART CREDIT **** * 2984 1 1
APPROVAL # 900303
REF # 1042000314
TRANS ID - 611319699900303
VALIDATION -
PAYMENT SERVICE -
AID A000000817001001
TC 2C127D5865371898
TERMINAL # SC011010
*NO SIGNATURE REQUIRED

CHANGE DUE 13:24:55 0.00
ITEMS SOLD 12
TC# 1538 8178 6598 7081 6919

Pam BB Tournament

ST# 00022	OP# 008365	TE# 03	TR# 09277	
DR PEPPER	004900001278	F	9.78	0
DR PEPPER	007800008210	F	9.78	0
DR PEPPER	007800008310	F	9.78	0
DR PEPPER	004900001063	F	9.78	0
GV .5L WATER	007874227909	F	4.38	0
GV .5L WATER	007874227909	F	4.38	0
FOAM PLATES	004400004738	F	4.98	0
NAB MULTIPAC	004400004738	F	4.98	0
NAB MULTIPAC	004400004738	F	4.98	0
NAB MULTIPAC	004400004738	F	4.98	0
MULTIPACK	002840036144	F	15.98	0
SUBTOTAL				87.76
TOTAL				87.76

Give us feedback @ survey.walmart.com
Thank you! ID #:7QD2147PLI

Walmart *

918-825-6000 Mgr:PHILLIP

Wally 10-8-21



10/22/21 13:13
***CUSTOMER COPY**

WALMART CREDIT TEND
WALMART CREDIT **** * 2984 1 1
APPROVAL # 732584
REF # 1042000314
TRANS ID - 101295655732584
VALIDATION -
PAYMENT SERVICE -
AID A000000817001001
TC A2660C34E7EAD07
TERMINAL # SC011364
*NO SIGNATURE REQUIRED

CHANGE DUE 13:12:
ITEMS SOLD 7
TC# 3100 4676 4684 6441

ST# 00022	OP# 008268	TE# 06	TR#	
GV .5L WATER	007874227909	F	4.38	0
GV .5L WATER	007874227909	F	4.38	0
CNKE	004900001063	F	9.78	0
DR PEPPER	007800008210	F	9.78	0
DR PEPPER	007800008310	F	9.78	0
FG 11.30Z CL	002550000365	F	4.98	0
FLVD CRMR	007874233371	F	4.98	0
SUBTOTAL				47.24
TOTAL				47.24

Give us feedback @ survey.walmart.com
Thank you! ID #:7QD547F2S

Walmart *

918-825-6000 Mgr:PHILLIP

Wally 10-8-21

Give us feedback @ survey.walmart.com
Thank you! ID #:7QF4CM7HNM



918-825-6000 Mgr:PHILLIP

4901 S MILL ST
PRYOR OK 74361

ST# 00022	OP# 007131	TE# 06	TR# 03591	
GV .5L WATER	007874227909	F	4.38	0
GV .5L WATER	007874227909	F	4.38	0
GV .5L WATER	007874227909	F	4.38	0
DR PEPPER	1 007800008210	F	9.78	0
DR PEPPER	007800008310	F	9.78	0
COKE	004900001063	F	9.78	0
MULTIPACK	002840036171	F	15.98	0
NAB MULTIPAC	004400004738	F	4.98	0
NAB MULTIPAC	004400004738	F	4.98	0
NAB MULTIPAC	004400004738	F	4.98	0
NAB MULTIPAC	004400004738	F	4.98	0
NAB MULTIPAC	004400004738	F	4.98	0
NAB MULTIPAC	004400004738	F	4.98	0

SUBTOTAL 83.36
TOTAL 83.36

WALMART CREDIT TEND 83.36

WALMART CREDIT **** * 2984 I 1

APPROVAL # 643475

REF # 1042000314

TRANS ID - 541334688643475

VALIDATION -

PAYMENT SERVICE -

AID A000000817001001

TC 3BCF1524E2EEE001

TERMINAL # SC011364

*NO SIGNATURE REQUIRED

11/30/21 13:07:47

CHANGE DUE 0.00

ITEMS SOLD 12

TC# 8259 6940 4476 8164 1747



11/30/21 13:07:57

CUSTOMER COPY

Pam Arnold

Give us feedback @ survey.walmart.com
Thank you! ID #:7QFDCX7KWV



918-825-6000 Mgr:PHILLIP

4901 S MILL ST
PRYOR OK 74361

ST# 00022	OP# 008323	TE# 03	TR# 05737	
GV .5L WATER	007874227909	F	4.38	0
3 AT 1 FOR			13.14	0
DR PEPPER	1 007800008210	F	9.78	0
MULTIPACK	002840036171	F	15.98	0
MULTIPACK	002840036171	F	15.98	0
NABISCO CKY	004400002024	F		
8 AT 1 FOR			39.84	0

SUBTOTAL 94.72

TOTAL 94.72

WALMART CREDIT TEND 94.72

WALMART CREDIT **** * 2984 I 1

APPROVAL # 216901

REF # 1042000314

TRANS ID - 621341702216901

VALIDATION -

PAYMENT SERVICE -

AID A000000817001001

TC 178CEAD6AA3FA55A

TERMINAL # SC011010

*NO SIGNATURE REQUIRED

12/07/21 13:30:26

CHANGE DUE 0.00

ITEMS SOLD 14

TC# 2516 9782 7639 5992 7383



12/07/21 13:30:36

CUSTOMER COPY

Give us feedback @ survey.walmart.com
Thank you! ID #:7QFFB17K26

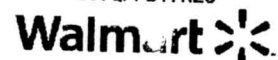

918-825-6000 Mgr:PHILLIP

4901 S MILL ST
PRYOR OK 74361

ST# 00022	OP# 006770	TE# 06	TR# 04942	
COKE	004900001063	F	9.78	0
GV NAP 400CT	007874233139	F	4.98	0
DR PEPPER	007800008310	F	9.78	0
FOAM PLATES	007874208830	F	4.24	0
MULTIPACK	002840036171	F	15.98	0
DR PEPPER	1 007800008210	F	9.78	0
GV .5L WATER	007874227909	F	4.38	0
GV .5L WATER	007874227909	F	4.38	0
GV .5L WATER	007874227909	F	4.38	0
NAB MULTIPAC	004400004738	F		
4 AT 1 FOR			19.92	0

SUBTOTAL 87.60

TOTAL 87.60

WALMART CREDIT TEND 87.60

WALMART CREDIT **** * 2984 I 1

APPROVAL # 153423

REF # 1042000314

TRANS ID - 301350684153423

VALIDATION -

PAYMENT SERVICE -

AID A000000817001001

TC 69B4615DBE9B057A

TERMINAL # SC011364

*NO SIGNATURE REQUIRED

12/16/21 13:00:19

CHANGE DUE 0.00

ITEMS SOLD 13

TC# 2671 2138 0162 4625 5696



U8He



2727 S. Memorial Drive • Tulsa, OK 74129
918-665-7083 • Fax: 918-664-5754

CUSTOMER

INVOICE

PAGE 1

INVOICE DATE 06/13/22
INVOICE NO. 00151597

SOLD TO: PRYOR HIGH SCHOOL WRESTLING
1100 SE 9TH ST
PRYOR OK 74361

SHIP TO: 038664

TOTAL DUE 655.04

SLS 1	SLS 2	DUE DATE	DISC DUE DATE	ORDER NO.	ORDER DATE	SHIP DATE	SHIP NO.
08		06/13/22		0001	10/25/21	06/01/22	038664
TERMS DESCRIPTION		CUSTOMER P.O. NUMBER			SHIP VIA		
CASH ON DELI.		60220197			UPS GROUND		
ITEM ID	UNIT OF MEASURE	ORDERED	SHIPPED	UNIT PRICE	EXTENSION		
WRESTLING MEDALS - TOTAL 216	01	216.0000	216.0000	1.6900	365.04		
8X10 CHAMPIONS PLAQUES - TOTAL 4	00	4.0000	4.0000	35.0000	140.00		
7X9 BANNER-UP PLAQUES - TOTAL 4	00	4.0000	4.0000	50.0000	200.00		
GRAND TOTAL				655.04	655.04		
TAXABLE	NONTAXABLE	FREIGHT	SALES TAX	MISC CHARGE	TOTAL		
.00	625.04	30.00	.00	.00	655.04		



PO 60220446

Purchasing, PPS <purchasing@pryorschools.org>

6519

Re: Invoice 10353 from Premier Signs & Design, LLC

1 message

Day, David <dayd@pryorschools.org>
To: PPS Purchasing <purchasing@pryorschools.org>

Thu, Jan 27, 2022 at 8:37 AM

All items received, please pay. PO attached

On Tue, Jan 18, 2022 at 3:54 PM Premier Signs & Design, LLC <quickbooks@notification.intuit.com> wrote:

INVOICE 10353



PremierSignsDesign.com

Premier Signs & Design, LLC

DUE 01/28/2022

\$210.00

Review and pay

Powered by QuickBooks

Dear PRYOR PUBLIC SCHOOLS,

Here's your invoice! We appreciate your prompt payment.
Thanks for your business!

Please send any replies to Info@PremierSignsDesign.com, do not reply to this email.

Premier Signs & Design, LLC

Wet
3-11-22

-01418-OK-P

Restaurant #01418
315 S Mill
Pryor, OK 74361
Phone 918-825-3192

4:49:23 PM
AC8CKLJALAC

Register 500
: 30

B+ Cheddar

DT362

2/\$6 Everyday Value (#6)	\$30.00
10 Tender Ched Ranch	
5 CPN - 2/\$6 Everyday Value (#6)	\$30.00
10 RB Classic	
5 CPN - 2/\$6 Everyday Value (#6)	\$30.00
10 BnC Classic	
Sub Total	\$90.00
MOB	\$90.00
*** 9747	\$90.00

Arnold
0031010

--> Order Closed <--

We would love your feedback!
Visit arbys.com/feedback
Join our team!
Text RBA to 97211

Wet
3-11-22

RBA-01418-OK-Pryor

Restaurant #01418
315 S Mill
Pryor, OK 74361
Phone 918-825-3192

11/30/2021 4:32:53 PM
Order Id: AAC8CKG2ACBL

pryor hs 4:30 - Eat In
Employee: Register 100
Total Items: 30

pryor hs 4:30

5 CPN - 2/\$6 Everyday Value (#6)	\$30.00
10 Tender Ched Ranch	
5 CPN - 2/\$6 Everyday Value (#6)	\$30.00
10 RB Classic	
5 CPN - 2/\$6 Everyday Value (#6)	\$30.00
10 BnC Classic	
Sub Total	\$90.00
PD# 60220286	
Order Total	\$90.00

Visa AUTHORIZED AMOUNT \$90.00

Card#: *****9747
Authorization: 005829

Arnold
0031010

ATD: A0000000031010

--> Order Closed <--

We would love your feedback!
Visit arbys.com/feedback
Join our team!
Text RBA to 97211

01418-OK-Pryor

Restaurant #01418
315 S Mill
Pryor, OK 74361
Phone 918-825-3192

4:25:58 PM

AC8CKLQAEAB
1 - Eat In
Register 200
125

pryor school

5 BnC Classic \$511.25
5 RB Classic \$511.25
5 Tender Ched Ranch \$511.25
MOUNT \$511.25

*****9747
ation: 14

003101

-> Order Closed <--

We would love your feedback!
Visit arbys.com/feedback
Join our team!
Text RBA to 97211

Handwritten signature

6488
1-13-22
RBA-01418-OK-Pryor

Restaurant #01418
315 S Mill
Pryor, OK 74361
Phone 918-825-3192

12/7/2021 5:24:38 PM
Order Id: AAC8CKHGACBK
pryor hs - Eat In
Employee: Register 100
Total Items: 30

pryor hs

5 CPN - 2/\$6 Everyday Value (@6) \$30.00
10 BnC Classic
5 CPN - 2/\$6 Everyday Value (@6) \$30.00
10 RB Classic
5 CPN - 2/\$6 Everyday Value (@6) \$30.00
10 Tender Ched Ranch
Sub Total: \$90.00
Order Total \$90.00
Visa \$90.00
AUTHORIZED AMOUNT \$90.00
Card#: *****9747
Authorization: 092247

AID: A0000000031010

Handwritten signature
Closed <--

We would love your feedback!
Visit arbys.com/feedback
Join our team!
Text RBA to 97211

PO# 60220286

TURN ME OVER

*Le left
3/1/22*

PIZZA HUT# 013863
501 S #1111 ST
Pryor, OK 74361
(918)825-4880
SALE

Server: RAEGAN
02/08/22
Ticket #25
4:06 PM

*****9747
DUPLICATE: 012949
Invoice #15

107.87

TIP:

Total:

I agree to pay above total amount according to card issuer agreement.

Signature



Customer Copy

Driver gratuity not included

70 \$ 1022028

PARTY ON THE BACK

THE BACK (TURN ME OVER)

PIZZA HUT
DELIVERY

** DUE NOW **
** DUE: 11/18/21 at 05:00PM **

Ticket #: 0025

Item Charge

ENTERED BY DEEDRAH 013863 12:54PM

PRYOR PIZZA
1100 SE
BURDITT

(918)

XX: F-06

AC 02 49.90

03 45.90

04 21.90

04 21.90

PARTY ON THE BACK (TURN ME OVER)

PARTY ON THE BACK

Wife
12-16-21

ON THE BACK (TURN ME OVER)

PARTY ON THE BACK (TURN ME OVER)

PART

15	1	Bottle Pepsi	2.19
OLD	16	1 Bottle Pepsi	2.19
OLD	17	1 Bottle Pepsi	2.19
OLD	18	1 Bottle Pepsi	2.19
OLD	19	1 Bottle Pepsi	2.19
OLD	20	1 Bottle Pepsi	2.19
OLD	21	1 Bottle Pepsi	2.19
OLD	22	1 Bottle Pepsi	2.19
OLD	23	1 Bottle Pepsi	2.19

COUPON	46.00
Subtotal	95.60
Deliver / Charge	3.99
SALES TAX	0.00
Balance Due	99.59
Ant. Tendered	99.59
Credit Card Amt Due	0.00

Driver gratuity not included



PIZZA HUT# 013863
501 S Mill ST
Pryor, OK 74361
(918)825-4880
SALE

*Called
12/16/21*

PARTY ON THE BACK (TURN ME OVER)

Server: ARVEN Ticket #1
11/16/21 4:35 PM
U
*****9747
APPR CODE: 047056 Invoice #15
AMOUNT: 99.59
TIP: 5.00
Total: 104.59

I agree to pay above total amount
according to card issuer agreement.

Signature: *[Signature]*

Customer Copy

Driver gratuity
not included

*PO# 60220289
9th BB
Turn*

PARTY ON THE BACK (TURN ME C

**PIZZA HUT
DELIVERY**

*6488
1-13-2022*

PARTY ON THE BACK (TURN ME OVER)

** DUE NOW **
** DUE: 12/02/21 at 04:30PM **

Ticket # 0002

Item Count: 50

ENTERED BY
INDY
013053 12/16/21 12:51PM

POW DRINKS
1100 SE 9TH ST
PULASKI CENTER

(918)825-2340

sys: F-0

01 10 Cheese Beef 49.
02 10 Pan Pizza 9.96
03 15 Soft Drink 32.05
Bottle Pepsi 32.05

Subtotal 165.50
Delivery Charge 3.99
SALES TAX 0.00
Balance Due 169.49

Aut. Entered
Credit Card 169.49
Aut. Due 3.00

Driver gratuity
not included

**EARN FREE PIZZA
WITH HUT REWARDS
ANY WAY YOU ORDER**

Restricti

ons Apply

Join Hut Rewards for free at

Pizzahut.com/Rewards

PARTY ON THE BACK (TURN ME OVER)

PARTY ON THE BACK (TURN ME OVER)

PART

60220350
1571
2-9-22



Welcome to Our Restaurant!

Promise Time: 1/20, 3:50 PM

1/13/22, 2:21 PM Ticket: Togol

Dine In Table 34
Invoice: 220113-05-1

45 Hot Turkey, Bacon & Swiss 427.50
No Drink .00
Bistro Chips .00
1 Choco cake 2 40.00
1 Brownies 20.00
1 Bags 14.00

Subtotal 501.50
Total 501.50

Pam Arnold

Suggested Tips
15%=75.23 18%=90.27 20%=100.30

RTI Tournament

Thank you for visiting us!

1/20/22 Scan to Pay



Earn Rewards!

Download Our Guest App

lelet
3/12



Welcome to Our Restaurant!

Pam Pryor Highschool

1/25/22, 12:01 PM

Ticket: Togo2

Server: Marty M

Catering

Pam Pryor Highschool

Invoice: 220120-05-2

20 Chicken Sandwich	190.00
No Drink	.00
Bistro Chips	.00
1 Chocolate cake	20.00
1 Strawberry	20.00
Subtotal	230.00
<hr/>	
Total	230.00
<hr/>	

Thank you for visiting us!

60220350

Pam Arnold.

PIT Tournament.

PO # 60220355

BILL & RUTH'S SUB SHOP ✓
310 S MILL ST 6488
PRYOR OK 74361 1-13-22
918-825-1009

Terminal ID: *****075 ***3
12/13/21 3:32 PM

VISA - MANUAL

ACCT #: *****9747

CREDIT SALE

UID: 134719428159 REF #: 6099

BATCH #: 932 AUTH #: 079590

AVS: Z

AMOUNT \$134.00

TIP \$ _____

TOTAL \$ _____

APPROVED

Pam Arnold

I AGREE TO PAY THE ABOVE TOTAL
AMOUNT ACCORDING TO CARD
ISSUER AGREEMENT
(MERCHANT AGREEMENT
IF CREDIT VOUCHER)

MERCHANT COPY

HS BB Game 12/14/21

PO # ^{Pam} 60220355

BILL & RUTH'S SUB SHOP ✓
310 S MILL ST
PRYOR OK 74361
918-825-1009

Terminal ID: *****075 ***3
12/13/21 3:30 PM

VISA - MANUAL

ACCT #: *****9747

CREDIT SALE

UID: 134742137011 REF #: 6098

BATCH #: 932 AUTH #: 031134

AVS: Z

AMOUNT \$134.85

TIP \$ _____

TOTAL \$ _____

APPROVED

Pam Arnold

I AGREE TO PAY THE ABOVE TOTAL
AMOUNT ACCORDING TO CARD
ISSUER AGREEMENT
(MERCHANT AGREEMENT
IF CREDIT VOUCHER)

MERCHANT COPY

HS WR match 12/16/21

BILL AND RUTH'S ✓
310 S MILL ST
PRYOR, OK 74361
918-8251009

REG 01-18-2022 12:14
000033

1-22-22

\$373.78

25 lb sand 224.75
50 cookies 50.00
50 chips 99.03

TL \$373.78
CREDIT \$373.78

PIT Tournament
Pam Arnold

PO # 60220355

BILL & RUTH'S SUB SHOP
310 S MILL ST
PRYOR OK 74361
918-825-1009

Terminal ID: *****068
1/18/22 12:14 PM

VISA CREDIT - INSERT
AID: A0000000031010
ACT #: *****9747

CREDIT SALE

UID: 201824498738 REF #: 4853
BATCH #: 951 AUTH #: 044343
AMOUNT \$373.78

TIP \$
TOTAL \$

APPROVED
Pam Arnold
AROC - BE0739A46EFE42E9
CUSTOMER COPY

MURUGUWAN

9800
HECK
90807
POT-DESSERT-BEV

1	LG COLD	T1	\$134.85
1	CANCEL	T1	\$2.00
1	LG COLD	T1	\$134.85
1	TOTAL	T1	\$136.85
1	TAX	T1	\$13.49
1	TOTAL	T1	\$136.85
1	TOTAL	T1	\$136.87
1	TOTAL	T1	\$136.87

6571 J
BILL AND RUTH'S
310 S MILL ST
PRYOR, OK 74361
918-8251009
REG 01-13-2022 14:32
000036

15 LG COLD T1 \$134.85
1 CANCEL T1 \$2.00
1 LG COLD T1 \$134.85
TOTAL T1 \$136.85
TAX T1 \$13.49
TOTAL T1 \$136.85
TOTAL T1 \$136.87

Pam Arnold

BILL AND RUTH'S
310 S MILL ST
PRYOR, OK 74361
918-8251009

REG 01-13-2022 14:34
000036

15 LG COLD T1 \$134.85
SUBTOTAL \$134.85
10%
%-
1 TA1 T1 -13.49
TX1 \$2.00
TL \$13.51
CREDIT \$136.87
\$136.87

reorder #122319 MADE IN THE USA



It's just that good!

6514
1-27-2022 141132
INVOICE

34 S. Mill • PRYOR, OK 74361 • (918) 325-5885 • Fax: (918) 325-9229 • Email: fountain33@aol.com

DATE: 1/5/23

S O L D	Pryor Public Schools (Pam) PO # 60220337	S H I P	We appreciate, your business.
----------------------------	--	----------------------------	----------------------------------

CUST. ORDER NO.	DATE SHIPPED	SHIPPED VIA	TERMS	SALESMAN	F.O.B.	OUR ORDER NO.
-----------------	--------------	-------------	-------	----------	--------	---------------

QTY. ORDERED	B/O	QTY. SHIPPED	DESCRIPTION	UNIT PRICE	AMOUNT
35			3 Chunk Dinner w/ drink (includes: plates, cups, ice)	11. ⁰⁸	384. ⁸⁰
2			Banana Pudding	33. ³⁹	66. ⁷⁸
1			Set of Serving Utensils		5. ⁰⁰
			Tom Arnold Thank You!		No Tax
				Total	\$459. ⁵⁸

INVCC-755-2
PRINTED IN U.S.A.

Thank You

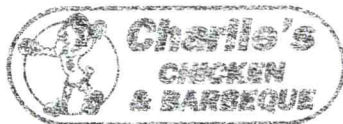

it's just that good!

1445
INVOICE

34 S. Mill • PRYOR, OK 74361 • (918) 325-5885 • Fax: (918) 825-8229 • Email: fountain38@aol.com

DATE: 1/17/22

SOLD TO	Pryor Schools		SHIP TO
	PO# 60220337		

We appreciate your business!

CUST. ORDER NO.	DATE SHIPPED	SHIPPED VIA	TERMS	SALESMAN	F.O.B.	OUR ORDER NO.
-----------------	--------------	-------------	-------	----------	--------	---------------

QTY. ORDERED	B/O	QTY. SHIPPED	DESCRIPTION	UNIT PRICE	AMOUNT
30			3 Chuck Dinners PK-GB (Boxed)		272 ⁷⁰
<i>Sarah Hunt</i>			<i>Thank You!</i>		No Tax
					<i>Total</i>

INVCC-755-2
PRINTED IN U.S.A.

Thank You



1449
INVOICE

34 S. Mill • PRYOR, OK 74361 • (918) 825-5885 • Fax: (918) 825-9229 • Email: fountain38@aol.com

DATE: 1-20-22

S O L D T O	<p>Pit</p> <p>Pam Arnold</p>	S H I P T O	<p>Thank you!</p> <p>We Appreciate your business!</p>
--	------------------------------	--	---

CUST. ORDER NO.	DATE SHIPPED	SHIPPED VIA	TERMS	SALESMAN	F.O.B.	OUR ORDER NO.
-----------------	--------------	-------------	-------	----------	--------	---------------

QTY. ORDERED	B/O	QTY. SHIPPED	DESCRIPTION	UNIT PRICE	AMOUNT
		20	Chunks: Wedges Carrot Cake Boxed - Sauce	8.68	173.60
			PO# 60220337		NO tax
					<u>173.60</u>

INVCC-755-2
PRINTED IN U.S.A.

Thank You



It's just that good!

1448
INVOICE

34 S. Mill • PRYOR, OK 74361 • (918) 825-5885 • Fax: (918) 825-8220 • Email: fountain38@aol.com

DATE: 1-20-22

SOLD TO	PIT Pam Arnold	SHIP TO	Thank you! We appreciate your business!
----------------	-------------------	----------------	--

CUST. ORDER NO.	DATE SHIPPED	SHIPPED VIA	TERMS	SALESMAN	F.O.B.	OUR ORDER NO.
-----------------	--------------	-------------	-------	----------	--------	---------------

QTY. ORDERED	B/O	QTY. SHIPPED	DESCRIPTION	UNIT PRICE	AMOUNT
		50	Chunks - wedges chc cake Boxed - Sauce PO# 60220337	\$ 8.68	434.00 No tax <hr/> 434.00

INVCC-755-2
PRINTED IN U.S.A.

Thank You



It's just that good!

1432

INVOICE

34 S. Mill • PRYOR, OK 74361 • (918) 825-8885 • Fax: (918) 825-9229 • Email: fountain38@aol.com

DATE: 12-17-2021

SOLD TO
Pryor High School
Pam
60220337

SHIP TO
Thank you!
We appreciate your business!

CUST. ORDER NO.	DATE SHIPPED	SHIPPED VIA	TERMS	SALESMAN	F.O.B.	OUR ORDER NO.
-----------------	--------------	-------------	-------	----------	--------	---------------

QTY. ORDERED	B/O	QTY. SHIPPED	DESCRIPTION	UNIT PRICE	AMOUNT
		30	chunks - pg - Roll	6.69	200.70
			Tam Donald.		No tax
			yes		200.70

INVCC-755-2
PRINTED IN U.S.A.

Thank You

PO # 60220338

JL'S BAR-B-Q ✓ 6571
5501 SOUTH MILL
PRYOR, OK 74361 2-9-22
(918) 825-RIBS (7427)

Date: 01/22/22 Time: 11:30 am

Order #: 101

COUNTER

PAM

Server: Sarah31

100 Dinners
50-Beef
50-Ribs

Paid: Paid

Payment #: 1082763

Payment Date Time: 01/22/22 11:30 am

Transaction ID: CH101

Cashier: Jeremy221

Tax ID: 45152

Merchant ID: 88430090920=JLSBAR

XXXXXXXXXXXX9747 Visa

Swiped

Invoice: 443528 Auth Code: 028611

Reference: 0011

Sub-total: \$1,649.00

Tax: Exempt

Total: \$1,649.00

Visa \$1,649.00

Tip : _____

Total : _____

Paul Donald

Customer Copy

We appreciate your business!

Please Come Again

6571 2-9-22
 PO# 60220335
 LAS FUENTES MEXICAN REST
 110 S MILL ST
 PRYOR, OK 74361
 918-824-1303
 CT2-2000536802

01/21/2022 18:02

Sale

Trans #: 85 Batch #: 25

VISA CHIP
 *****9747 **/**

BASE AMT: \$138.60
 SUC: \$4.85
 DISC: \$0.00

SUB TOTAL: \$143.45

TIP AMT: \$

TOTAL AMT: \$

Pam Donald
 Resp: APPROVAL 028625
 Code: 028625
 Ref #: 202200000169
 TransID: 302022002987505

App Name: VISA CREDIT
 AID: A0000000031010
 TUR: 8083008000
 TSI: 6800

THANK YOU
 COME AGAIN!
 CUSTOMER COPY

~~562.50~~
 FOOD FT1 \$0.25
 FOOD FT1 \$0.25
 FOOD FT1 \$0.25
 FOOD FT1 \$0.25
 FOOD FT1 \$0.25
 FOOD FT1 \$0.25
 FOOD FT1 \$0.25
 TAX1 ~~\$50.56~~
 TOTAL ~~\$562.50~~
 CASH ~~\$562.50~~
 CLERK 1 341125 00000

~~\$562.00~~
 \$ 529.92
 # 6571
 2-9-22

6571
3-11-22
 LAS FUENTES MEXICAN REST
 110 S MILL ST
 PRYOR, OK 74361
 918-824-1303
 CT2-2000536802

01/28/2022 14:07

Sale

Trans #: 48 Batch #: 32

VISA CHIP
 *****9747 **/**

BASE AMT: \$232.20
 SUC: \$8.13
 DISC: \$0.00

SUB TOTAL: \$240.33

TIP AMT: \$

TOTAL AMT: \$

Resp: APPROVAL 012783
 Code: 012783
 Ref #: 202820203091
 TransID: 462028726110718

App Name: VISA CREDIT
 AID: A0000000031010
 TUR: 8080008000
 TSI: 6800

Carol Hunt

THANK YOU
 COME AGAIN!
 CUSTOMER COPY

Las Fuentes of Oklahoma, Inc.
 110 S. Mill
 Pryor, OK 74361 ..0.. ✓

6488 8.99 x
1-13-22 75. =
 674.25 +

Las Fuentes of Oklahoma, Inc.
 110 S. Mill
 Pryor, OK 74361

5.00 +
 679.25 00

Carol Hunt 679.25 00

Transaction ID: ...
 Suprvd: Online Batch#: 000038

Customer Copy

0045

Server: CRYSTAL S (#101) Rec: 23
01/21/22 11:12, Chip T: 801 Term: 1

Thomas Restaurant
215 S. Mill Street
Pryor, OK 74361
(918)824-4700

6571
2-9-22

Name: FUND_TRAVEL_2/ACTIVITY
TID 775813280001

Purchase

VISA CREDIT XXXXXXXXXXXX9747
CVM SIGN
Invoice 0004517265
Response APPROVED
Auth Code 094612

EMV DETAILS

MODE CHIP
AID A0000000031010
TVR 8080008000
IAD 06010A03A08000
TSI 6800
ARC Z3
Amount USD \$448.48

Chk Total: 448.48

Tip: _____

Total: _____

Pam Arnold

Duplicate
top copy -> customer
Suggested Gratuity
15 PERCENT 67.27
18 PERCENT 80.73
20 PERCENT 89.70

Customer Copy

FD # 60220334

0109

Server: CLAUDIA G (#25) Rec: 83
01/22/22 13:39, Chip T: 101 Term: 1

Thomas Restaurant
215 S. Mill Street
Pryor, OK 74361
(918)824-4700

Name: FUND_TRAVEL_2/ACTIVITY
TID 775813280001

Purchase

VISA CREDIT XXXXXXXXXXXX9747
CVM SIGN
Invoice 0010919006
Response APPROVED
Auth Code 080257

EMV DETAILS

MODE CHIP
AID A0000000031010
TVR 8080008000
IAD 06010A03A08000
TSI 6800
ARC Z3
Amount USD \$51.96

Chk Total: 51.96

Tip: _____

Total: _____

Pam Arnold

Duplicate
top copy -> customer
Suggested Gratuity
15 PERCENT 7.09
18 PERCENT 8.51
20 PERCENT 9.46

Customer Copy

FD # 60220334

PO# 60220405

Give us feedback @ survey.walmart.com
Thank you! ID #:7RDMOF7P4N

Walmart

4/1/22
3-8-2022

918-825-6000 Mgr:PHILLIP
4901 S MILL ST
PRYOR OK 74361

ST# 00022	OP# 008365	TE# 04	TR# 08862		
GV .5L WATER	007874227909	F	4.58	0	
GV .5L WATER	007874227909	F	4.58	0	
GV .5L WATER	007874227909	F	4.58	0	
GV .5L WATER	007874227909	F	4.58	0	
COKE	004900001278	F	9.78	0	
DR PEPPER	007800008216	F	5.68	0	
DR PEPPER	007800008216	F	5.68	0	
DR PEPPER	007800008216	F	5.68	0	
DR PEPPER	007800008216	F	5.68	0	
DR PEPPER	007800008216	F	5.68	0	
DR PEPPER	007800008216	F	5.68	0	
MULTIPACK	002840036171	F	16.98	0	
FOAM PLATES	007874208000	F	4.56	0	
30Z CROWD F	004400005029	F	10.78	0	
30Z CROWD F	004400005029	F	10.78	0	
UTILE BTR	004400004631	F	3.98	0	
UTILE BTR	004400004631	F	3.98	0	
MULTIPACK	002840036171	F	16.98	0	
SUBTOTAL			132.62		
TOTAL			132.62		

WALMART CREDIT TEND 132.62

WALMART CRDIT **** * 2984 I 1

APPROVAL # 866130

REF # 1042000314

TRANS ID - 082039708866130

VALIDATION -

PAYMENT SERVICE -

AID A000000817001001

TC 10A551082408841C

TERMINAL # SC010995

*NO SIGNATURE REQUIRED

02/08/22 13:41:31

CHANGE DUE 0.00

ITEMS SOLD 18

TC# 8699 4614 5757 6666 1276 7

Walmart



Give them the gift
of membership
Scan to gift today.

02/08/22 13:41:45
CUSTOMER COPY

Give us feedback @ survey.walmart.com
Thank you! ID #:7RDXPB7FP5

Walmart

4/1/22

918-825-6000 Mgr:PHILLIP
4901 S MILL ST
PRYOR OK 74361

ST# 00022	OP# 007131	TE# 01	TR# 01686		
3CT BLUE TC	001117999593		2.63	0	
3CT BLUE TC	001117999593		2.63	0	
3CT BLUE TC	001117999593		2.63	0	
20Z SAV	J04400006464	F	6.98	0	
UTILE BTR	004400008845	F	5.34	0	
UTILE BTR	004400004100	F	7.98	0	
UTILE BTR	001370013761	F	5.18	0	
UTILE BTR	004200035503	F	5.34	0	
UTILE BTR	007800008216	F	9.78	0	
SUBTOTAL			48.49		
TOTAL			48.49		

WALMART CREDIT TEND 48.49

WALMART CREDIT **** * 2984 I 1

APPROVAL # 816603

REF # 1042000314

TRANS ID - 142060578816603

VALIDATION -

PAYMENT SERVICE -

AID A000000817001001

TC C46AE3A6062A51A7

TERMINAL # SC010270

*NO SIGNATURE REQUIRED

03/01/22 10:04:45

CHANGE DUE 0.00

ITEMS SOLD 9

TC# 4386 9044 3539 9198 5303



Walmart



Become a
member today
Scan for 30-day free trial.

03/01/22 10:04:58
CUSTOMER COPY

PO # 60220405

Feedback @ survey.walmart.com
Thank you! ID #: 7RD9YV7NWY



lele03

918-825-6000 Mgr: PHILLIP

4901 S MILL ST
PRYOR OK 74361

ST# 00022	OP# 006770	TE# 09	TR# 08623
GV .5L WATER	007874227909	F	3.98 0
WAS 4.38	YOU SAVED 0.40		
GV .5L WATER	007874227909	F	3.98 0
WAS 4.38	YOU SAVED 0.40		
GV .5L WATER	007874227909	F	3.98 0
WAS 4.38	YOU SAVED 0.40		
GV .5L WATER	007874227909	F	3.98 0
WAS 4.38	YOU SAVED 0.40		
GV .5L WATER	007874227909	F	3.98 0
WAS 4.38	YOU SAVED 0.40		
COKE	004900001063	F	9.78 0
COKE	004900001063	F	9.78 0
DR PEPPER	1 007800008210	F	9.78 0
DR PEPPER	1 007800008210	F	9.78 0
DR PEPPER	1 007800008210	F	9.78 0
COKE	004900001278	F	9.78 0
COKE	004900001278	F	9.78 0
DR PEPPER	007800008310	F	9.78 0
DR PEPPER	007800008310	F	9.78 0
3CT BLUE TC	001117999593		2.63 0
3CT BLUE TC	001117999593		2.63 0
3CT BLUE TC	001117999593		2.63 0
GV 2RL TOWEL	007874232973		3.67 0
GV 2RL TOWEL	007874232973		3.67 0
VNTYFAIR NAP	004200035503		4.92 0
LIQUID DISH	007874234731		4.98 0
SUBTOTAL			137.03
TOTAL			137.03

WALMART CREDIT TEND

WALMART CREDIT **** * 2984 I 1

APPROVAL # 165162
REF # 1042000314
TRANS ID - 092021560165162

VALIDATION -
PAYMENT SERVICE -
AID A000000817001001
TC 4E60644ED68EB2C4
TERMINAL # SC810169

Paul Arnold

*NO SIGNATURE REQUIRED
01/21/22 09:33:37
CHANGE DUE 0.00
ITEMS SOLD 22
TC# 6260 2444 3898 4424 8785 8



Give them the gift
of membership
Scan to gift today.

01/21/22 09:33:48
CUSTOMER COPY

Give us feedback @ survey.walmart.com
Thank you! ID #:7RD9N37KG8



918-825-6000 Mgr:PHILLIP
4901 S MILL ST
PRYOR DK 74361

ST# 00022 OP# 008365 TE# 04 TR# 05316

KFT SINGLES	002100061526 F	3.97 0
12Z KF SNG	002100006563 F	3.28 0
KFT SINGLES	002100061526 F	3.97 0
12Z KF SNG	002100006563 F	3.28 0
KFT SW SINGL	002100060469 F	3.28 0
HC 12OZ ORG	002823900612 F	5.93 0
HSY AST PRTY	003400039991 F	9.98 0
3CT BLUE TC	001117999593	2.63 0
3CT BLUE TC	001117999593	2.63 0
3CT BLUE TC	001117999593	2.63 0
3CT BLUE TC	001117999593	2.63 0
** VOIDED ENTRY **		
3CT BLUE TC	001117999593	2.63 0
MC CHC STN	061278110119 F	5.97 0
MC CHC STN	061278110119 F	5.97 0
MULTIPACK	002840036171 F	15.98 0
MULTIPACK	002840036171 F	15.98 0
PILLSBURY 20	001800073412 F	4.34 0
PILLSBURY 20	001800073412 F	4.34 0
PILLSBURY 20	001800073412 F	4.34 0
PILLSBURY 20	001800073412 F	4.34 0
PILLSBURY 20	001800073412 F	4.34 0
PILLSBURY 20	001800073412 F	4.34 0
DR PEPPER 1	007800008210 F	9.78 0
DR PEPPER 1	007800008210 F	9.78 0
DR PEPPER 1	007800008210 F	9.78 0
COKE	004900001063 F	9.78 0
GV .5L WATER	007874227909 F	3.98 0
WAS 4.38	YOU SAVED 0.40	
GV .5L WATER	007874227909 F	3.98 0
WAS 4.38	YOU SAVED 0.40	
DR PEPPER	007800008310 F	9.78 0
DR PEPPER	007800008310 F	9.78 0
DR PEPPER	007800008310 F	9.78 0
GV .5L WATER	007874227909 F	3.98 0
WAS 4.38	YOU SAVED 0.40	
GV .5L WATER	007874227909 F	3.98 0
WAS 4.38	YOU SAVED 0.40	
COKE	004900001063 F	9.78 0
COKE	004900001063 F	9.78 0
COKE	004900001278 F	9.78 0
COKE	004900001278 F	9.78 0
COKE	004900001278 F	9.78 0
COKE	004900001278 F	9.78 0
MC BNAN CRM	061278110109 F	5.97 0
MC BNAN CRM	061278110109 F	5.97 0
VN1YFAIR NAP	004200035503	4.92 0
FRUIT TRAY	068113118022 F	12.97 0
FRUIT TRAY	068113118022 F	12.97 0
WATERMELON	068113118066 F	4.48 0
LIFESAVERS	001900017030 F	9.98 0
FOAM PLATES	007874208830	4.24 0

SUBTOTAL 301.96
TOTAL 301.96

WALMART CREDIT TEND 301.96
WALMART CREDIT **** * 2984 I 1

APPROVAL # 436970
REF # 1042000314
TRANS ID - 742018594436970
VALIDATION -
PAYMENT SERVICE -
AID A000000817001001
TC EFC0215607C15CD6
TERMINAL # SC010995
*NO SIGNATURE REQUIRED

01/18/22 10:30:46
CHANGE DUE 0.00

ITEMS SOLD 43

TC# 8217 5799 8545 7727 3659 5



Give them the gift
of membership
Scan to gift today

Give us feedback @ survey.walmart.com
Thank you! ID #:7RDP2V7FH8



918-825-6000 Mgr:PHILLIP
4901 S MILL ST
PRYOR DK 74361

ST# 00022 OP# 006180 TE# 01 TR# 01503

GV .5L WATER	007874227909 F	4.58 0
GV .5L WATER	007874227909 F	4.58 0
GV .5L WATER	007874227909 F	4.58 0
GV .5L WATER	007874227909 F	4.58 0
GV .5L WATER	007874227909 F	4.58 0
GV .5L WATER	007874227909 F	4.58 0
COKE	004900001278 F	9.78 0
COKE	004900001278 F	9.78 0
COKE	004900001063 F	9.78 0
COKE	004900001063 F	9.78 0
NABISCO CKY	004400004100 F	7.98 0
DR PEPPER	007800008310 F	9.78 0
NAB MULTIPAC	004400004738 F	5.34 0
NAB MULTIPAC	004400004738 F	5.34 0
DR PEPPER	007800000386 F	3.28 0
JR PEPPER	007800000386 F	3.28 0
DR PEPPER	007800000386 F	3.28 0
DR PEPPER	007800000386 F	3.28 0

SUBTOTAL 108.16

TOTAL 108.16

WALMART CREDIT TEND 108.16

WALMART CREDIT **** * 2984 I 1

APPROVAL # 583204
REF # 1042000314
TRANS ID - 802059556583204
VALIDATION -
PAYMENT SERVICE -
AID A000000817001001
TC 4CAAF987BCFDBD56
TERMINAL # SC010270
*NO SIGNATURE REQUIRED

02/28/22 09:27:38
CHANGE DUE 0.00

ITEMS SOLD 18

TC# 5716 3936 6353 9949 5530 3



Become a
member today
Scan for 30-day free trial.

02/28/22 09:27:51
CUSTOMER COPY

PIT
Tournament

HOMELANDTM

YOUR HOMEGROWN ADVANTAGE

70 # 60220414
 925 S. MILL ST
 Store: (918) 825-5795

Pam Arnold

Your Cashier Today Is: CUSTOMER
 TRANSACTION RETRIEVED:

RETRIEVAL NUMBER: 4/82
 Welcome Rewards Member 41453824609
 CHOC CHIP COOKIE 4.29 B
 8 @ 2.79
 HMLND DRINKING W 22.32 B
 CHOC CHIP COOKIE 4.29 B
 BC UCRN FR SGR 3.49 B
 9CT CHOC PNUT BT 3.99 B
 9CT CHOC PNUT BT 3.99 B
 9CT CHOC PNUT BT 3.99 B
 9CT CHOC PNUT BT 3.99 B
 10CT SNKRDDLES 5.99 B
 10CT SNKRDDLES 5.99 B
 CHINET 7OCT APP& 8.49 T
 CHINET 7OCT APP& 8.49 T
 CHINET 7OCT APP& 8.49 T
 CHINET 7OCT APP& 8.49 T
 Grocery-Price 1.39 B
 TAX 9.65
 TAX EXEMPTION 9.65-
 **** TOTAL DUE 97.68
 OP Customer Charge 97.68
 CHANGE 0.00
 TOTAL NUMBER OF ITEMS SOLD = 22

01/22/22 12:38pm 539 30 25 810



YOUR FEEDBACK MATTERS!

Tell us about this visit at
thisgroceryvisit.com
 or scan the QR code above

Chance to WIN \$100 GIFT CARD
 3 WINNERS EACH MONTH
 Hablamos Espanol

Valid for 7 days from visit

↓ Survey code below ↓

0325 1202 2520 2391

INVOICE 1-27-22

6515

Ship To: HAC, Inc
 AR / Customer Charges
 PO Box 25008
 Oklahoma City, OK 73125



TERMS
NET 28 DAYS

STORE NUMBER	
CUSTOMER NUMBER	256661
INVOICE NUMBER	642485
DATE	012222

	PRICE	AMOUNT
	2.79	22.32
<i>Kees</i>		
<i>Flakes</i>		
TAX		0
TOTAL		97.68

CUSTOMER PURCHASE ORDER NUMBER

CASHIER B. Franklin

YES NO TAX EXEMPT STATUS

ING
 IER

6759

RBA-01418-OK-Pryor

Restaurant #01418
315 S Mill
Pryor, OK 74361
Phone 918-825-3192

4/1/2022 11:37:46 AM

Order Id: AAC8CKGNAEAR
Pryor hs - Eat In
Employee: Register 200
Total Items: 46

pryor hs

23 CPN - 2/\$6 Everyday Value (06) \$138.00
46 RB Classic
*Cheddar Sauce \$34.50
Sub Total \$172.50

Order Total \$172.50
Visa AUTHORIZED AMOUNT \$172.50
Card#: *****9747
Authorization: 085691

AID: A0000000031010
Tom Donald

--> Order Closed <--

We would love your feedback!
Visit arbys.com/feedback
Join our team!
Text RBA to 97211

60220629

6810
6-8-2022

RBA-01418-OK-Pryor

Restaurant #01418
315 S Mill
Pryor, OK 74361
Phone 918-825-3192

3/25/2022 11:10:18 AM

Order Id: AAC8CKPBAEAD
Pryor school - Eat In
Employee: Register 200
Total Items: 30

Pryor school

15 CPN - 2/\$6 Everyday Value (06) \$90.00
30 RB Classic
Sub Total \$90.00

Order Total \$90.00
Visa AUTHORIZED AMOUNT \$90.00
Card#: *****9747
Authorization: 020998

AID: A0000000031010
Tom Donald

--> Order Closed <--

We would love your feedback!
Visit arbys.com/feedback
Join our team!
Text RBA to 97211

60220629

6759

RBA-01418-OK-Pryor

Restaurant #01418
315 S Mill
Pryor, OK 74361
Phone 918-825-3192

4/21/2022 3:55:22 PM

Order Id: AAL8CKRWAEBZ
h - Eat In
Employee: Register 200
Total Items: 30

h

15 CPN - 2/\$6 Everyday Value (06) \$90.00
30 RB Classic
Sub Total \$90.00

Order Total \$90.00
Visa AUTHORIZED AMOUNT \$90.00
Card#: *****9747
Authorization: 051889

AID: A0000000031010
Tom Donald

--> Order Closed <--

We would love your feedback!
Visit arbys.com/feedback
Join our team!
Text RBA to 97211



6759

BILL & RUTH'S SUB SHOP

310 S MILL ST

PRYOR OK 74361

918-825-1009

Terminal ID: *****068 ***2

4/20/22 3:48 PM

VISA - MANUAL

ACCT #: *****9747

CREDIT SALE

UID: 211038106753 REF #: 7020

BATCH #: 321 AUTH #: 061397

AMOUNT \$150.36

TIP \$-----

TOTAL \$-----

APPROVED

CUSTOMER COPY

Terminal ID: *****068 ***2

3/28/22 2:10 PM

VISA CREDIT - INSERT

AID: A0000000031010

ACCT #: *****9747

CREDIT SALE

UID: 20872710609 REF #: 6389

BATCH #: 003 AUTH #: 028889

AMOUNT \$109.56

TIP *9.00* \$-----

TOTAL \$-----

APPROVED

CUSTOMER COPY

ARC - 076571EED1B51809

CUSTOMER COPY

Sam Donald

BILL & RUTH'S SUB SHOP

310 S MILL ST

PRYOR OK 74361

918-825-1009

Terminal ID: *****068 ***2

3/28/22 2:10 PM

VISA CREDIT - INSERT

AID: A0000000031010

ACCT #: *****9747

CREDIT SALE

UID: 20872710609 REF #: 6389

BATCH #: 003 AUTH #: 028889

AMOUNT \$109.56

TIP *9.00* \$-----

TOTAL \$-----

APPROVED

CUSTOMER COPY

ARC - 076571EED1B51809

CUSTOMER COPY

Sam Donald

4-12-22

BILL & RUTH'S SUB SHOP

310 S MILL ST

PRYOR OK 74361

918-825-1009

Terminal ID: *****068 ***2

4/13/22 4:23 PM

VISA - MANUAL

ACCT #: *****9747

CREDIT SALE

UID: 210342401023 REF #: 6856

BATCH #: 016 AUTH #: 015262

AMOUNT \$133.34

TIP \$-----

TOTAL \$-----

APPROVED

CUSTOMER COPY

ARC - 076571EED1B51809

CUSTOMER COPY

Sam Donald

12 LG GOLD 11 17.88

4 CHIPS 11 447.76

SUBTOTAL 11 447.76

10% 44.78

TAX 4

PAID \$205.34

EX1 \$24.78

TIP \$205.34

TOTAL \$205.34

TIP \$-----

TOTAL \$-----

APPROVED

CUSTOMER COPY

ARC - 076571EED1B51809

CUSTOMER COPY

Sam Donald

BILL & RUTH'S SUB SHOP

310 S MILL ST

PRYOR OK 74361

918-825-1009

Terminal ID: *****068 ***2

4/13/22 4:23 PM

VISA - MANUAL

ACCT #: *****9747

CREDIT SALE

UID: 210342401023 REF #: 6856

BATCH #: 016 AUTH #: 015262

AMOUNT \$133.34

TIP \$-----

TOTAL \$-----

APPROVED

CUSTOMER COPY

ARC - 076571EED1B51809

CUSTOMER COPY

Sam Donald

6759

BILL & RUTH'S SUB SHOP

310 S MILL ST

PRYOR OK 74361

918-825-1009

Terminal ID: *****068 ***2

3/28/22 2:10 PM

VISA CREDIT - INSERT

AID: A0000000031010

ACCT #: *****9747

CREDIT SALE

UID: 20872710609 REF #: 6389

BATCH #: 003 AUTH #: 028889

AMOUNT \$109.56

TIP *9.00* \$-----

TOTAL \$-----

APPROVED

CUSTOMER COPY

ARC - 076571EED1B51809

CUSTOMER COPY

Sam Donald

BILL & RUTH'S SUB SHOP

310 S MILL ST

PRYOR OK 74361

918-825-1009

Terminal ID: *****068 ***2

4/13/22 4:23 PM

VISA - MANUAL

ACCT #: *****9747

CREDIT SALE

UID: 210342401023 REF #: 6856

BATCH #: 016 AUTH #: 015262

AMOUNT \$133.34

TIP \$-----

TOTAL \$-----

APPROVED

CUSTOMER COPY

ARC - 076571EED1B51809

CUSTOMER COPY

Sam Donald

TURN ME OVER)

PARTY ON THE BACK (TURN ME OVER)

PARTY ON THE BACK (TURN ME OVER)

16.18
 16.18
 16.18
 16.18
 06 1 16.18
 7.14
 52.94
 3.99
 0.00
 96.93
 0.00

Amt Tendered
 Credit Card
 Amt Due

Tom Donald
 Driver gratuity # 602220635
 not included PD

PARTY ON THE BACK (TURN ME OVER)

PARTY ON THE BACK (TURN ME OVER)

✓
 6789
 5172

PIZZA HUT# 013863
 501 S Mill St
 Pryor, OK 74361
 (918)825-4880
SALE

Server: BRITANNA Ticket #26
 03/24/22 3:31 PM
 *****9747
 APPR CODE: 028618 Invoice #18
 AMOUNT: 108.12
 TIP: 5.00
 Total: 113.12

I agree to pay above total amount
 according to card issuer agreement.

Signature *Tom Donald*

Customer Copy

Driver gratuity
 not included

ACK (TURN ME OVER)

PARTY ON THE BACK (TURN ME OVER)

PARTY ON THE BACK (TURN ME OVER)

680
 ✓

PIZZA HUT# 013863
 501 S Mill St
 Pryor, OK 74361
 (918)825-4880
SALE

Server: Ticket #1
 04/29/22 11:04 AM
 *****9747
 APPR CODE: 028618 Invoice #18
 AMOUNT: 96.07
 TIP:
 Total:

I agree to pay above total amount
 according to card issuer agreement.

Signature:

Merchant Copy

Driver gratuity
 not included

Tom Donald
 Driver gratuity # 602220635
 not included PD

OVER)

PARTY ON THE BACK (TURN ME OVER)

PARTY ON THE BACK (TURN ME OVER)

Subtotal 54.08
 Delivery Charge 3.99
 SALES TAX 0.00
 Balance Due 98.07

Aut Handled
 Credit Card
 Aut Due 98.07
 0.00

Driver gratuity
 not included

EARN FREE PIZZO
 WITH OUR REWARDS
 ANY WAY YOU ORDER

RESTRICTIONS APPLY

Join Our Rewards For Free
 Pizzat.com/Rewards

HOW DID WE DO?

CODE: Enter #100 W42

We're always improving our pizza game!

Enter the code above to tell us about
 your experience at

tel: 1-800-333-3333

For Special Deals Order
 Online at Pizzat.com

PARTY ON THE BACK (TURN ME OVER)

PARTY ON THE BACK (TURN ME OVER)

P.

6759

PIZZA HUT# 013863
 501 S Mill ST
 Pryor, OK 74361
 (918)825-4880
SALE

Server: ARWEN
 04/02/22
 Ticket #1
 11:06 AM

*****9747
 APPR CODE: 080398
 Invoice #1

AMOUNT: 97.33

TIP:

Total:

Order to pay the total amount
 according to card issuer agreement.

Signature

Customer Copy

Driver gratuity
 not included

Tom Bernardi
 #60209535

PARTY ON THE BACK (TURN ME OVER)

PARTY ON THE BACK (T

6759

04 1 Large 16.18
 Cheese
 Pork
 Thin

05 1 Large 16.18
 Cheese
 Beef
 Large
 Thin

06 1 Large 16.18
 Cheese
 Pepperoni
 Large
 Thin

COUPON (OA) DISCOUNT 7.14
 Subtotal 92.94
 Delivery Charge 3.99
 SALES TAX 0.00
 Balance Due 96.93

Aut Handled
 Credit Card
 Aut Due 96.93
 0.00

Driver gratuity
 not included

**WE'RE ALWAYS
 IMPROVING OUR**

OVER)

PARTY ON THE BACK (TURN ME OVER)

PARTY ON THE BACK (TURN ME OV

Deliver Charge 3.99
SALES TAX 0.00
Balance Due 98.07

2810

98.07
0.00

Accepted
Card

Driver gratuity
not included

Daryl Hester

WIN FREE PIZZA
WITH HOT REWARDS
ANY WAY YOU ORDER

Restrict

www.pizzahut.com

Join hot rewards for free at
pizzahut.com/rewards

How did we do?

Great! 100% Great!

We're always improving our service. Thank you!

Enter the code above to tell us about
your experience at

1-800-4-A-Pizza

© 2008 Pizzeria Uno Group, Inc. All rights reserved. Pizzeria Uno Group, Inc. is a registered trademark of Pizzeria Uno Group, Inc.

For Special Deals Order
Online at Pizzahut.com



R)

PARTY ON THE BACK (TURN ME OVER)

PARTY ON THE BACK (TUR

04	1	Large	16.18
05	1	Large	16.18
06	1	Large	16.18
07	1	Large	16.18
COUPON (TA, TH, FR, SA, I)			7.74
Subtotal			104.13
Deliver Charge			3.99
TAX			0.00
Balance Due			108.12
Not Tended			108.12
Credit Card			0.00

Driver gratuity

PAULIES DAYLIGHT DONUTS
319 S MILL ST
PRYOR, OK 74361
9183738000

Merchant ID: 0516
Term #: 0001

Store #: 5611
Ref #: 0018

Sale

XXXXXXXXXXXX9747

VISA

Entry Method: Chip

Amount:\$ 56.00

Tip:

Total: 56.00

04/11/22 09:53:39

Inv #: 000013 Appr Code: 036169

Transaction ID: 302101536190577

Apprvd: Online Batch#: 000060

VISA CREDIT

AID: A0000000031010

TSI: 6800

TVR: 8000008000

Paul Donald
Customer Copy

THANK YOU

PO # 60220647

PAULIES DAYLIGHT DONUTS
319 S MILL ST
PRYOR, OK 74361
9183738000

Merchant ID: 0516
Term #: 0001

Store #: 5611
Ref #: 0026

Phone Order

XXXXXXXXXXXX9747

VISA

Entry Method: Manual

Amount:\$ 17.00

Tip:

Total:

04/05/22

Inv #: 000018

Appr Code: 036169

Transaction ID: 302095541612348

Apprvd: Online

Batch#: 000055

AVS Code: ZIP MATCH Z

CVV2 Code: MATCH M

PO #: 60220647

PO # 60220647

See to pay above total amount
according to card issuer agreement
(Merchant agreement if credit voucher)

Paul Donald

Merchant Copy

THANK YOU

Give us feedback @ survey.walmart.com
Thank you! ID #: 7RF-8M3/DMS



918-825-6000 Mgr: PHILLIP
4901 S HILL ST
PRVOR OK 74361

ST#	00022	OP#	008365	TE#	03	TR#	00694	0
42CT	CLAS	MP	002840069435	F			16.98	0
42CT	FLAV	MP	002840069437	F			16.98	0
NAB	MULTI	PAC	004400004738	F				
6	AT	1	FOR	5.34			32.04	0
NV	SMT	SLTY	001600016053	F			6.27	0
GV	5L	WATER	007874227909	F			4.58	0
GV	5L	WATER	007874227909	F			4.58	0
GV	5L	WATER	007874227909	F			4.58	0
GV	5L	WATER	007874227909	F			4.58	0
COKE			004900001278	F			9.78	0
DR	PEPPER		007800008216	F			5.68	0
COKE			004900001063	F			9.78	0
DR	PEPPER		007800008310	F			6.27	0
NV	SMT	SLTY	001600016059	F			6.27	0
SNACK	CAKE		002430004320	F			4.48	0
SNACK	CAKE		002430004350	F			4.48	0
SUBTOTAL							139.84	
TOTAL							139.84	
WALMART CREDIT TEND							2984	1

WALMART CREDIT ***** 2984 1 1
 APPROVAL # 361451
 REF # 1042000314
 TRANS ID - 2020796685361451 60220639
 VALIDATION -
 PAYMENT SERVICE -
 ATD A000000817001001
 TC E2BF49BE24AE2EA
 TERMINAL # SCOTT1010
 *NO SIGNATURE REQUIRED
 04/06/22 14:02:17
 CHANGE DUE 0.00

14:02:17

CHANGE DUE 0.00

ITEMS SOLD 20

IC# 5846 7911 4333 9989 0731 3



Become a member today
Scan for 30-day free trial.

04/06/22 14:02:30
CUSTOMER COPY

Give us feedback @ survey.walmart.com
Thank you! ID #: 7RF-827/N81



918-825-6000 Mgr: PHILLIP
4901 S HILL ST
PRVOR OK 74361

ST#	00022	OP#	002697	TE#	02	TR#	08030	0
CLBY	KC	CHEESE	026232980427	F			4.27	0
DELUXE	HAM		026232980427	F			3.99	0
TURKEY	DELI		026233420464KF	F			4.64	0
COOKWARE			001090026516	F			4.24	0
NAB	MULTI	PAC	004400004738	F			5.76	0
NAB	MULTI	PAC	004400004738	F			5.76	0
NAB	MULTI	PAC	004400004738	F			5.76	0
SNACK	CAKE		002430004320	F			4.48	0
SNACK	CAKE		002430004320	F			4.48	0
SUBTOTAL							43.38	
TOTAL							43.38	
WALMART CREDIT TEND							2984	1

WALMART CREDIT ***** 2984 1 1
 APPROVAL # 876222
 REF # 1042000314
 TRANS ID - 592011676876222
 VALIDATION -
 PAYMENT SERVICE -
 ATD A000000817001001
 TC OFF09766D740BA05
 TERMINAL # SC010669
 *NO SIGNATURE REQUIRED
 04/01/22 13:48:09
 CHANGE DUE 0.00

13:48:09

CHANGE DUE 0.00

ITEMS SOLD 9

IC# 0513 3422 6211 6131 232



Become a member today
Scan for 30-day free trial.

04/01/22 13:48:21
CUSTOMER COPY

Give us feedback @ survey.walmart.com
Thank you! ID #: 7RD/Z97KLD

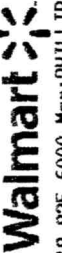

918-825-6000 Mgr: PHILLIP
4901 S HILL ST
PRVOR OK 74361

ST#	00022	OP#	000598	TE#	01	TR#	05444	0
KSHR	SLACKER		005410012378	F			2.67	0
VL	ZESTY	DIL	005410006160	F			2.67	0
7.5	OZ	ULTR	004610000221	F			2.86	0
7.5	OZ	SLIC	004610000121	F			2.86	0
8	OZ	SLICED	004610000114	F			2.86	0
7.5	OZ	SLIC	004610000121	F			2.86	0
GV	SAND	WHT	007874214813	F			0.93	0
GV	SAND	WHT	007874214813	F			0.93	0
OV	FAM	CHMO	004470007353	F			6.00	0
16Z	DE	HAN	004470007261	F			6.00	0
16OZ	DR	TURK	004470007014	F			6.00	0
16Z	MSO	CHK	004470009727	F			6.00	0
FOOD	BAG		007874234966	F			4.78	0
MUSTARD	200Z		004150000031	F			2.48	0
19ZKFT	MM	SO	002100009945	F			4.18	0
VNTY	FAIR	NAP	004200035503	F			5.34	0
3CT	BLUE	TC	001117999593	F			2.63	0
3CT	BLUE	TC	001117999593	F			2.63	0
COKE			004900001278	F			9.78	0
COKE			004900001278	F			9.78	0
DR	PEPPER		007800008210	F			8.78	0
DR	PEPPER		007800008210	F			8.78	0
DR	PEPPER		007800008310	F			8.78	0
DR	PEPPER		007800008310	F			8.78	0
GV	5L	WATER	007874227909	F			4.58	0
GV	5L	WATER	007874227909	F			4.58	0
GV	5L	WATER	007874227909	F			4.58	0
GV	5L	WATER	007874227909	F			4.58	0
42CT	CLAS	MP	002840069435	F			16.98	0
42CT	CLAS	MP	002840069435	F			16.98	0
COKE			004900001063	F			9.78	0
COKE			004900001063	F			9.78	0
CR	JCKD	CRNL	002840009971	F			1.88	0
CR	JCKD	CRNL	002840009971	F			1.88	0
GV	SWICH	WHT	007874201228	F			0.93	0
GV	SWICH	WHT	007874201228	F			0.93	0
NAB	MULTI	PAC	004400004738	F			0.93	0
4	AT	1	FOR	5.76			23.04	0
12/200Z	PNUT		007874236708	F			1.98	0
12/200Z	PNUT		007874236708	F			1.98	0
FOAM	PLATE		001370013761	F			5.18	0
SNACK	CAKE		002430004320	F			17.92	0
4	AT	1	FOR	4.48			251.58	
SUBTOTAL							251.58	
TOTAL							251.58	
WALMART CREDIT ***** 2984 1 1							251.58	

WALMART CREDIT ***** 2984 1 1
 APPROVAL # 560084
 REF # 1042000314
 TRANS ID - 3120822688560684
 VALIDATION -
 PAYMENT SERVICE -
 ATD A000000817001001
 TC 8071082D79A10E56A
 TERMINAL # SC010270
 *NO SIGNATURE REQUIRED
 03/23/22 14:07:38
 CHANGE DUE 0.00

14:07:38

CHANGE DUE 0.00

ITEMS SOLD 48

IC# 2004 0670 2249 7101 0

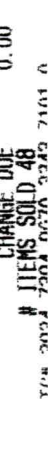
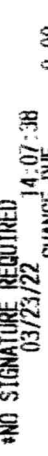

Become a member today
Scan for 30-day free trial.

03/23/22 14:07:38
CUSTOMER COPY

6727

60220639

Tom Donald

Tom Donald

60220639
Tom Donald

Give us feedback @ survey.walmart.com
Thank you! ID #: 7RF94766X

Walmart

918-825-6000 Mgr: PHILLIP
4901 S HILL ST
PRYOR OK 74361

ST# 00022 OP# 07822 IE# 03 TR# 02205
GV 5L WATER 007874227909 F 4.58 0
GV 5L WATER 007874227909 F 4.58 0
GV 5L WATER 007874227909 F 4.58 0
POWERADE 004900004566 F 4.98 0
POWERADE 004900004566 F 4.98 0
SUBTOTAL 28.68
WALMART CREDIT TEND 28.68
WALMART CREDIT **** 2984 1 1
APPROVAL # 296886
REF # 1042000314
TRANS ID - 852101690296886
VALIDATION -
PAYMENT SERVICE -
ATD A00000817001001
TC BEZG2BEF0677F97
TERMINAL # SC011010
*NO SIGNATURE REQUIRED
04/11/22 14:10:30
ITEMS SOLD 6
#0869 6776 8676 6561 4757

TC# 0869 6776 8676 6561 4757
CHANGE DUE 0.00

PO# 60220639
Walmart

Become a member today
Scan for 30-day free trial.

04/11/22 14:10:44
CUSTOMER COPY

PO# 60220639

Give us feedback @ survey.walmart.com
Thank you! ID #: 7RF8M47LB1

Walmart

918-825-6000 Mgr: PHILLIP
4901 S HILL ST
PRYOR OK 74361

ST# 00022 OP# 007545 IE# 04 TR# 06146
GV 5L WATER 007874227909 F 4.58 0
GV 5L WATER 007874227909 F 4.58 0
GV 5L WATER 007874227909 F 4.58 0
SPRITE 004900001938 F 9.78 0
DR PEPPER 1 007800008210 F 8.78 0
DR PEPPER 1 007800008210 F 8.78 0
COKE 004900001063 F 9.78 0
POWERADE 004900005074 F 4.98 0
POWERADE 004900005074 F 4.98 0
POWERADE 004900005074 F 4.98 0
SUBTOTAL 70.78
WALMART CREDIT TEND 70.78
WALMART CREDIT **** 2984 1 1
APPROVAL # 066391
REF # 1042000314
TRANS ID - 592096777066391
VALIDATION -
PAYMENT SERVICE -
ATD A00000817001001
TC AAA2767BE27295
TERMINAL # SC010995
*NO SIGNATURE REQUIRED
04/06/22 16:35:07
ITEMS SOLD 11
#6645 5703 1615 5254 7111

TC# 6645 5703 1615 5254 7111
CHANGE DUE 0.00

PO# 60220639
Walmart

Become a member today
Scan for 30-day free trial.

04/06/22 16:35:20
CUSTOMER COPY

PO# 60220639

Give us feedback @ survey.walmart.com
Thank you! ID #: 7RF9467PR2

Walmart

918-825-6000 Mgr: PHILLIP
4901 S HILL ST
PRYOR OK 74361

ST# 00022 OP# 008371 IE# 02 TR# 09433
CR SHORT BTR 005150024241 F 6.44 0
JELLY 005150001279 F 3.38 0
BKG POWDER 007874205410 F 1.36 0
BKG POWDER 007874205410 F 1.36 0
FLOUR 007007010009 F 2.42 0
FLOUR 007007010009 F 2.42 0
CC 15Z 0 002740010307 F 2.42 0
FLOUR 007007010009 F 2.42 0
FLOUR 007007010009 F 2.42 0
FLOUR 007007010009 F 2.42 0
GV COOK SPRY 007874222941 F 1.56 0
PLAIN SALT 007874235220 F 0.48 0
GV 2 007874235187 F 4.12 0
GV 2 007874235187 F 4.12 0
GV 2 007874235187 F 4.12 0
GV 2 007874235187 F 4.12 0
2LB ROLL SSG 007790011753 F 8.38 0
2LB ROLL SSG 007790011753 F 8.38 0
2LB ROLL SSG 007790011753 F 8.38 0
2LB ROLL SSG 007790011753 F 8.38 0
2LB ROLL SSG 007790011753 F 8.38 0
2LB ROLL SSG 007790011753 F 8.38 0
GV BAC TK 12 007874203089 F 3.72 0
SUBTOTAL 97.22
WALMART CREDIT TEND 97.22
WALMART CREDIT **** 2018 1 1
APPROVAL # 321386
REF # 1042000314
TRANS ID - 202101857321386
VALIDATION -
PAYMENT SERVICE -
ATD A00000817001001
TC 907A26643950A08E
TERMINAL # SC010669
*NO SIGNATURE REQUIRED
04/11/22 18:48:53
ITEMS SOLD 22
#1262 0143 2640 0000 0474

TC# 1262 0143 2640 0000 0474
CHANGE DUE 0.00

PO# 60220639
Walmart

Become a member today
Scan for 30-day free trial.

04/11/22 18:49:08
CUSTOMER COPY

PO# 60220639

6727

6800

Give us feedback @ survey.walmart.com
Thank you! ID #: 7RF6297N66



918-825-6000 Mgr.: PHILLIP
4901 S HILL ST
PRVOR OK 74361

ST# 00022	OP# 008310	IE# 04	TR# 08205	
16Z	DF HAM	004470007261	F	6.00
ROASTED	TKY	004470003050	F	2.94
SARG	PRV SLC	004610000694	F	2.38
7.5 OZ	SLIC	004610000121	F	2.18
LIFESAVERS		001900008504	F	2.18
LIFESAVERS		001900008504	F	2.18
FOAM PLATE		001370013761	F	5.34
NAB	MULTIPAC	004400004738	F	5.34
NAB	MULTIPAC	004400004738	F	5.34
NAB	MULTIPAC	004400004738	F	5.34
SNACK CAKE		002430004320	F	17.92
4 AT	1 FOR	4.48		0.93
GV SAND	WHI	007874214813	F	0.93
GV SWITCH	WHI	007874201228	F	0.93
BOUNTY	NAP	003700034885	F	3.17
GV .5L	WATER	007874227909	F	27.48
6 AT	1 FOR	4.58		8.78
DR PEPPER		007800008310	F	8.78
DR PEPPER		007800008310	F	8.78
DR PEPPER		007800008310	F	8.78
DR PEPPER		007800008210	F	8.78
DR PEPPER		007800008210	F	8.78
DR PEPPER		007800008210	F	150.13
DR PEPPER		007800008210	F	150.13
SUBTOTAL				2984.11
WALMART CREDIT TEND				0.00
APPROVAL # 834363				
REF # 1042000314				
TRANS ID - 622110668834363				
VALIDATION -				
PAYMENT SERVICE -				
AID A000000817001001				
TC F0602087EC351238				
TERMINAL # SC010995				
*NO SIGNATURE REQUIRED				
04/20/22 13:34:44				
# ITEMS SOLD 30				
TC# 3815 8513 5321 5595 3711 1				

WALMART CREDIT TEND 0.00
 APPROVAL # 834363
 REF # 1042000314
 TRANS ID - 622110668834363
 VALIDATION -
 PAYMENT SERVICE -
 AID A000000817001001
 TC F0602087EC351238
 TERMINAL # SC010995
 *NO SIGNATURE REQUIRED
 04/20/22 13:34:44
 CHANGE DUE
 # ITEMS SOLD 30
 TC# 3815 8513 5321 5595 3711 1



Become a member today
 Scan for 30-day free trial.

04/20/22 13:35:02
 CUSTOMER COPY

6800

Give us feedback @ survey.walmart.com
Thank you! ID #: 7RFBSW7PHY

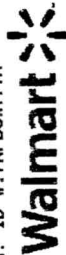

918-825-6000 Mgr.: PHILLIP
4901 S HILL ST
PRVOR OK 74361

ST# 00022	OP# 009598	IE# 04	TR# 09212	
GV .5L	WATER	007874227909	F	18.32
4 AT	1 FOR	4.58		9.22
NV OH	48CL	001600017384	F	5.34
NAB	MULTIPAC	004400004738	F	5.34
NAB	MULTIPAC	004400004738	F	5.34
NAB	MULTIPAC	004400004738	F	5.34
POWERADE		004900005643	F	9.96
2 AT	1 FOR	4.96		9.96
POWERADE		004900005075	F	8.78
2 AT	1 FOR	4.98		8.78
DR PEPPER		007800008310	F	81.04
DR PEPPER		007800008210	F	81.04
SUBTOTAL				2984.11
WALMART CREDIT TEND				0.00
APPROVAL # 413570				
REF # 1042000314				
TRANS ID - 242117699413570				
VALIDATION -				
PAYMENT SERVICE -				
AID A000000817001001				
TC 82A31ADD2C680509				
TERMINAL # SC010995				
*NO SIGNATURE REQUIRED				
04/27/22 14:25:44				
# ITEMS SOLD 14				
TC# 0782 0220 2640 0304 3424				

WALMART CREDIT TEND 0.00
 APPROVAL # 413570
 REF # 1042000314
 TRANS ID - 242117699413570
 VALIDATION -
 PAYMENT SERVICE -
 AID A000000817001001
 TC 82A31ADD2C680509
 TERMINAL # SC010995
 *NO SIGNATURE REQUIRED
 04/27/22 14:25:44
 CHANGE DUE
 # ITEMS SOLD 14
 TC# 0782 0220 2640 0304 3424



Become a member today
 Scan for 30-day free trial.

04/27/22 14:25:57
 CUSTOMER COPY

6800

Give us feedback @ survey.walmart.com
Thank you! ID #: 7RFCS97MQM

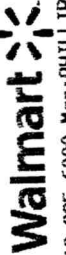

918-825-6000 Mgr.: PHILLIP
4901 S HILL ST
PRVOR OK 74361

ST# 00022	OP# 008437	IE# 03	TR# 07497	
42CL	FLAV MP	002840006943	F	16.98
PADR	SUG MIN	007874227233	F	2.98
CHOC	MN DNT	007874227234	F	2.98
CIN	MINI DNT	007874227235	F	2.98
DR PEPPER		007800008210	F	6.78
GV .5L	WATER	007874227909	F	4.58
GV .5L	WATER	007874227909	F	4.58
GV .5L	WATER	007874227909	F	4.58
GV .5L	WATER	007874227909	F	4.58
GV .5L	WATER	007874227909	F	53.02
GV .5L	WATER	007874227909	F	53.02
SUBTOTAL				2984.11
WALMART CREDIT TEND				0.00
APPROVAL # 793763				
REF # 1042000314				
TRANS ID - 242119479793763				
VALIDATION -				
PAYMENT SERVICE -				
AID A000000817001001				
TC FBFAE911F34372AD				
TERMINAL # SC011010				
*NO SIGNATURE REQUIRED				
04/29/22 08:19:42				
# ITEMS SOLD 9				
TC# 2166 9158 5239 9993 7373				

WALMART CREDIT TEND 0.00
 APPROVAL # 793763
 REF # 1042000314
 TRANS ID - 242119479793763
 VALIDATION -
 PAYMENT SERVICE -
 AID A000000817001001
 TC FBFAE911F34372AD
 TERMINAL # SC011010
 *NO SIGNATURE REQUIRED
 04/29/22 08:19:42
 CHANGE DUE
 # ITEMS SOLD 9
 TC# 2166 9158 5239 9993 7373



Become a member today
 Scan for 30-day free trial.

04/29/22 08:20:00
 CUSTOMER COPY



It's just that good!

U632
3-29-22

1479

INVOICE

• PRYOR, OK 74361 • (918) 825-5885 • Fax: (918) 825-9229 • Email: fountain38@aol.com

DATE: 3-25-22

SOLD TO	Pryor Public Schools Pam	SHIP TO	We appreciate your BUSINESS!
----------------	-----------------------------	----------------	---------------------------------

CUST. ORDER NO.	DATE SHIPPED	SHIPPED VIA	TERMS	SALESMAN	F.O.B.	OUR ORDER NO.
-----------------	--------------	-------------	-------	----------	--------	---------------

QTY. ORDERED	B/O	QTY. SHIPPED	DESCRIPTION	UNIT PRICE	AMOUNT
90			Chunks	1.59	143.10
PO. #		60220631	Pam Arnold Thank You!		

INVC-755-2
PRINTED IN U.S.A.

Thank You

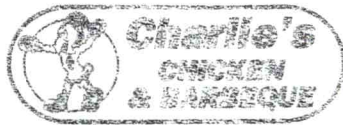

It's just that good!

34 S. Mill • PRYOR, OK 74361 • (918) 825-5885 • Fax: (918) 825-0229 • Email: fountain38@aol.com

1493
INVOICE

6706
5-5-22

DATE: 4-28-2022

S O L D T O	Pryor High School Pam Arnold PO# 60220631	S H I P T O	Thank you! We Appreciate your business!
--	---	--	---

CUST. ORDER NO.	DATE SHIPPED	SHIPPED VIA	TERMS	SALESMAN	F.O.B.	OUR ORDER NO.
		470# 60220852				

QTY. ORDERED	B/O	QTY. SHIPPED	DESCRIPTION	UNIT PRICE	AMOUNT
		90	Chunks - wedges - Rolls Boxed - Sauce <i>Daryl Hester</i>		602.10 No tax <hr/> <u>602.10</u>

INVCC-755-2
PRINTED IN U.S.A.

Thank You



It's just that good!

6683
4-21-22

1489

INVOICE

34 S. MAIN • PRYOR, OK 74361 • (918) 925-5885 • Fax: (918) 925-9129 • Email: fountain38@aol.com

DATE: 4-15-22

SOLD TO	Pryor High School		SHIP TO	Thank you!	
	Pam Arnold PO# 60220631			We Appreciate your business!	

CUST. ORDER NO.	DATE SHIPPED	SHIPPED VIA	TERMS	SALESMAN	F.O.B.	OUR ORDER NO.
-----------------	--------------	-------------	-------	----------	--------	---------------

QTY. ORDERED	B/O	QTY. SHIPPED	DESCRIPTION	UNIT PRICE	AMOUNT
		30	chunks and wedges Rolls - Sauce Boxed		200 70
			<i>Pam Arnold</i>		No tax
					<u>200 70</u>

INVCC-755-2
PRINTED IN U.S.A.

Thank You



It's just that good!

34 S. Mill • PRYOR, OK 74361 • (918) 825-5285 • Fax: (918) 825-9239 • Email: fountain38@aol.com

1482

INVOICE

6646
4-8-22

DATE: 4-1-22

S O L D	Pryor High School Pam Arnold	S H I P T O	Thank you! We appreciate your business!
----------------------------	---------------------------------	--	---

CUST. ORDER NO.	DATE SHIPPED	SHIPPED VIA	TERMS	SALESMAN	F.O.B.	OUR ORDER NO.
-----------------	--------------	-------------	-------	----------	--------	---------------

QTY. ORDERED	B/O	QTY. SHIPPED	DESCRIPTION	UNIT PRICE	AMOUNT
		240	Chunks <i>Daryl Weston</i> PO # 60220631		67.60 <hr/> No tax <hr/> 67.60

INVCC-755-2
PRINTED IN U.S.A.

Thank You



It's just not good!

34 S. MAIN • PRYOR, OK 74361 • (918) 825-5838 • Fax: (918) 825-9228 • Email: fountain3@aol.com

Teles

1481

414-21 INVOICE

DATE: 4-12-2022

SOLD TO		SHIP TO			
Fryer High School		Thank you!			
Pam Arnold		We Appreciate!			
Track meet PO# 60220764		Your business!			
CUST. ORDER NO.	DATE SHIPPED	SHIPPED VIA	OUR ORDER NO.		
TERMS	SALESMAN	F.O.B.			
QTY. ORDERED	B/O	QTY. SHIPPED	DESCRIPTION	UNIT PRICE	AMOUNT
			Ribs (802)		884.50
			Wedges (5) } per person		159.68
			Rolls (1)		53.91
			Boxed - BBQ Sauce - utensils		1098.09
			Boxed - BBQ Sauce - utensils		No tax
					1098.09

INVC-7552
PRINTED IN U.S.A.

Thank You Teles
4-14-22

PO # 08.09

PO 60220764



It's just that good!

44445
4-14-22

1483

INVOICE

34 S. Mill • PRYOR, OK 74361 • (918) 825-5855 • Fax: (918) 325-9239 • Email: fountain38@aol.com

DATE: 4-7-22

SOLD TO	Pryor High School Dawn Arnold 60220631	SHIP TO	Thank you! We appreciate your business!
----------------	--	----------------	--

CUST. ORDER NO.	DATE SHIPPED	SHIPPED VIA	TERMS	SALESMAN	F.O.B.	OUR ORDER NO.
-----------------	--------------	-------------	-------	----------	--------	---------------

QTY. ORDERED	B/O	QTY. SHIPPED	DESCRIPTION	UNIT PRICE	AMOUNT
		25	(B) Chicken - wedges - Roll		
		25	(B) Chicken - pj - Rolls Boxed		
					250.50
					127.25
					377.75

INVCC-755-2
PRINTED IN U.S.A.

Thank You

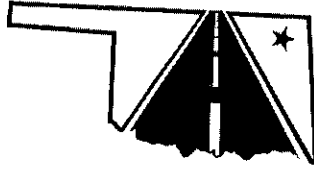

PRYOR MAIN STREET

2021- 2022 Hotel- Motel Allocation Expense Report

Amount Allocated- Expenses Submitted- **\$13,284.56**

Pryor Main Street - 8 South Vann, Pryor, OK 74361- Phone: (918)373-1373

Email: mainstreetpryor@gmail.com

Ballmom Designs.....	\$1031.95
Canva.....	\$118.97
Fresh Powder 918 LLC.....	\$2610
Highway 69ers.....	\$250
Kristy's Twisties Balloons.....	\$312.50
Little Cabin Catering.....	\$200
Mary Sue's Mobile Petting Zoo.....	\$550
Mayes County Event Center.....	\$750
Mid-Town Rentals.....	\$83.13
M & M Properties.....	\$4500
Party Perfect Rentals.....	\$911.06
Party Pro Rents.....	\$132.57
Sam's Club.....	\$179.82
Staples.....	\$104.56
The Sound DJ Services.....	\$1200
Tribe Circus Arts.....	\$350
Total.....	\$13,284.56

Ballmom Designs

Payment Type	Invoice #	Description	Amount
Check #1548	2206211	6.21.22 Tshirts for Downtown Promotion	\$355.95
Check #1456		8.24.21 Tshirts for Dancing with Pryor Stars Event	\$676
Total			\$1031.95

Pryor Main Street -8 South Vann, Pryor, OK 74361 - P: (918)373-1373
Email: mainstreetpryor@gmail.com

-

Canva

Payment Type	Invoice #	Description	Amount
Card 7967	21487415	2.4.22 Monthly subscription to design Service for event, business, and organization posters.	\$12.99
Card 7967	21977426	3.4.22 Monthly subscription to design Service for event, business, and organization posters.	\$12.99
Card 7967	36656515	3.23.22 Printed posters for Capitol Day advertising our events and programs in OKC	\$80
Card 7967	12485798	5.4.22 Monthly subscription to design Service for event, business, and organization posters.	\$12.99
Total			\$118.97

Pryor Main Street -8 South Vann, Pryor, OK 74361 - P: (918)373-1373

Email: mainstreetpryor@gmail.com

Fresh Powder 918 LLC (4.27.22)

Payment Type	Invoice #	Description	Amount
Check #1537	1481	Powder Coating for tornado monument	\$2610
Total			\$2610

Highway 69ers (Jason Wood) (5.26.22)

Payment Type	Invoice#	Description	Amount
Check #1546	203	Entertainment for Event	\$250
Total			\$250

Kristy's Twisties Balloons (4.20.22)

Payment Type	Invoice #	Description	Amount
Check # 1534	1901	Balloon artist for Downtown Carnival Event	\$312.50
Total			\$312.50

Little Cabin Catering (5.26.22)

Payment Type	Invoice #	Description	Amount
Check #1543			\$200
Total			\$200

Mary Sue's Mobile Petting Zoo (4.21.22)

Payment Type	Invoice #	Description	Amount
Check #1532	66	Petting zoo at Downtown Carnivla event	\$550
Total			\$550

Mayes County Fairground (8.12.21)

Payment Type	Invoice #	Description	Amount
Check #1454	198007	Event Center rental for Dancing with the Pryor Stars	\$750
Total			\$750

Pryor Main Street -8 South Vann, Pryor, OK 74361 - P: (918)373-1373

Email: mainstreetpryor@gmail.com

The Sound DJ Services (8.12.21)

Payment Type	Invoice #	Description	Amount
Card #7697	0169	DJ and lighting for Dancing with the Pryor Stars Event	\$1200
Total			\$1200

Tribe Circus Arts (4.22.22)

Payment Type	Invoice #	Description	Amount
Check #1535	0135	Entertainment for the Downtown Carnival	\$350
Total			\$350

Pryor Main Street -8 South Vann, Pryor, OK 74361 - P: (918)373-1373
Email: mainstreetpryor@gmail.com

Screenprinting, Embroidery, Banners Promotional Products
 1605 Larkspur Ct · Pryor OK 74361
 918.691.7652 merideth3@sbcglobal.net



ORDER: Jennie LaFave
PO: Pryor Main Street - Dancing with the Stars
DATE: 8.24.2021

FRONT:
 2/C Full front -white and gold ink

BACK:
 1/C Back - white ink

SHIRT DESCRIPTION	QUANTITY:	SIZE:	COST:	TOTAL:
Gildan Dryblend	12	S	\$10.00	\$120.00
COLOR: Black	18	M	\$10.00	\$180.00
	22	L	\$10.00	\$220.00
	22	XL	\$10.00	\$220.00
	12	2XL	\$12.00	\$144.00
	4	3XL	\$13.00	\$52.00

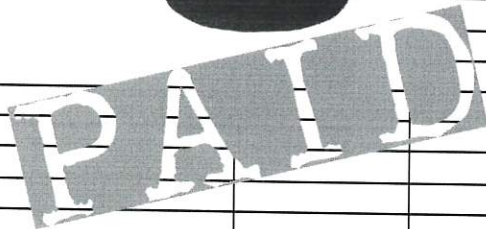

SUB TOTAL:	\$936.00
TRADE OUT TABLE:	\$260.00
TAX:	exempt
TOTAL:	\$676.00

Thank you for your order!

Fwd: Your Canva invoice

Pryor Main Street <mainstreetpryor@gmail.com>
To: info.mainstreetpryor@gmail.com

Fri, Jul 15, 2022 at 3:45 PM

hotel/motel

----- Forwarded message -----
From: **Canva** <no-reply@canva.com>
Date: Wed, May 4, 2022 at 10:07 AM
Subject: Your Canva invoice
To: <mainstreetpryor@gmail.com>



Your invoice

Thank you for your purchase! Your invoice details are below.

INVOICE

03410-12485798

DATE OF ISSUE

May 4, 2022

BRAND ID

BADcebRmIRg
Jennie VanBuskirk's team

BILLED TO

Card (Visa - 7967)

Details

ITEM	AMOUNT
Subscription charges	\$12.99

Charged:

\$12.99

[View details](#)

[View all invoices](#)

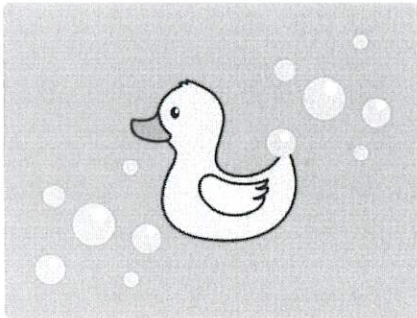

Did you know?

Bubbles keep your bath water warmer longer.

You received this email because you made a purchase on Canva. If this was sent to you by mistake, please contact support.



Made for you with  from Canva
Canva®, 110 Kippax St, NSW 2010, Australia

Date: Wed, 23 Mar 2022 20:06:35 +0000

Subject: Your **Canva invoice**



Your invoice

Thank you for your purchase! Your invoice details are below.

INVOICE

03368-36656515

DATE OF ISSUE

Mar 23, 2022

BRAND ID

BADcebRmIRg
Jennie VanBuskirk's team

BILLED TO

Card (Visa - 7967)

Details

ITEM	AMOUNT
Print items	\$55.00
Shipping	\$25.00

Charged:

\$80.00

Your invoice

Canva

Thank you for your purchase! Your invoice details are below.

INVOICE

03349-21977426

DATE OF ISSUE

Mar 4, 2022

BRAND ID

BADcebRmIRg
Jennie VanBuskirk's team

BILLED TO

Card (Visa - 7967)

Details

ITEM

AMOUNT

Subscription charges

\$12.99

Charged:

\$12.99

[View details](#)

[View all invoices](#)

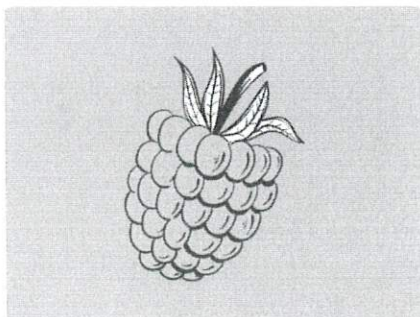

Did you know?

Grapes explode if you put them in the microwave.



Canva Your invoice

Thank you for your purchase! Your invoice details are below.

INVOICE

03321-21487415

DATE OF ISSUE

Feb 4, 2022

BRAND ID

BADcebRmIRg
Jennie VanBuskirk's team

BILLED TO

Card (Visa - 7967)

Details

ITEM

AMOUNT

Subscription charges

\$12.99

Charged:

\$12.99

[View details](#)

[View all invoices](#)



Fresh Powder 918 LLC

2737 Old Highway 20 E
(918)-833-2149
freshpowder918@yahoo.com

INVOICE
INV1481

DATE
04/27/2022

DUE DATE
05/27/2022

PO #
1481

BALANCE DUE
USD \$2,610.00

BILL TO

Pryor Main Street

DESCRIPTION	RATE	QTY	AMOUNT
Sand Blasting \$100.00 Per Hour	\$100.00	3.5	\$350.00
Powder Coating Materials Exterior Copper Vein / PureCoat Gloss Clear / Exterior Black Vein	\$460.00	1	\$460.00
80 sq ft. 3/8" plate Powder coated in IFS Exterior Copper Vein base, IFS Purecoat Gloss Clear Coat	\$13.00	80	\$1,040.00
8' x 4' 8" Aluminum Plate Washed, 220 grit sanded to prep, and clear coated in IFS Purecoat Gloss Clear Coat	\$230.00	1	\$230.00
8' Frame, 4" Sq Tubing Sand blasted, and powder coated in IFS Exterior Black Vein base, IFS Purecoat Gloss Clear Coat	\$225.00	2	\$450.00
Pick up from Elite Manufacturing. Delivered to Pryor Public Library. Truck & Trailer	\$40.00	2	\$80.00

TOTAL **\$2,610.00**

BALANCE DUE **USD \$2,610.00**

Invoice
Jason Wood HWY 69rs

BILL TO
Pryor Main Street
Point of Contact: Jennie LaFave, Jason Wood

Invoice# 203
Date May 26, 2022
Due Date May 26, 2022

Item	Quantity	Price	Amount
------	----------	-------	--------

Live music for event	1	\$250.00	\$250.00
----------------------	---	----------	----------

Subtotal \$250.00
Total \$250.00
Amount due \$250.00





**KRISTIE'S TWISTIES BALLOONS
AND ENTERTAINMENT**

215 N ORPHAN ST
PRYOR. OK
74361

PRYOR MAIN STREET
8 S. VANN ST
PRYOR. OK
74361

INVOICE NO: 1901

SERVICE

TIME

PRICE

Professional balloon artist

2.5 HRS.
HR

\$125.00

\$312.50

SUB TOTAL

EVENT DETAILS

\$312.50 DUE

ENTERTAINMENT/ HIRED BY:
PRYOR MAIN STREET

EVENT DATE

4-20-22

THANK YOU!
WE LOOK FORWARD
TO YOUR EVENT

MAKE YOUR PAYMENT TO

Remaining balance is due the day
of your event

KRISTIE'S TWISTIES BALLOONS
AND ENTERTAINMENT
CHECK OR PAY ONLINE WITH ANY MAJOR
CREDIT CARD
WWW.KRISTIESTWISTIES.COM
CELL 918-850-8478



Little Cabin Catering
31590 S 4320 Rd
Big Cabin, OK 74332

Pryor Main Street
% Jennie LaFave

May 26, 2022

PMS Farm to Table Dinner

Honey Glazed Carrots, Asparagus, Blueberry Cheesecake

TOTAL \$200.00

Payment due upon delivery.

Thank you for your business!

RECEIPT

No. 198007

DATE 8-12-21

\$ 750⁰⁰

FROM Fryor Main Street (Jenny Lafave) Seven Hundred Fifty Dollars & ²⁹/₁₀₀ DOLLARS

FOR RENT
 FOR Marys County Event Center

ACCT.	
PAID	750 ⁰⁰
DUE	

- CASH
- CHECK
- MONEY ORDER
- CREDIT CARD

FROM 8-12-21 TO 8-13-21

BY Jenny Lafave

A-1152
T-4161

Invoice

Mary Sue's Mobile Petting Zoo LLC

Marysuesmobilepettingzoo@gmail.com
 P.O. Box 1384
 Haskell OK 74436
 (918)230-9261



BILL TO

Pryor Main Street
 Point of Contact: Jennie LaFave, Marsha White

Invoice # 66
Date Apr 21, 2022
Due date Apr 21, 2022

Item	Quantity	Price	Amount
Big Party Package Petting Zoo, Pony Carousel, and Farm Barrel Train Ride,	1	\$550.00	\$550.00

Subtotal \$550.00
 Total \$550.00

Amount Due **\$550.00**

Midtown Rental, Sales & Serv

302 S.J.M Davis Blvd.
Claremore, OK 74017
918-342-0775

CONTRACT# 65191 INVOICE# 66010

DATE/TIME IN: 04/22/2022 11:08 AM

DATE/TIME OUT: 04/21/2022 12:19 PM

Closed Contract/Invoice

ADDRESS AT WHICH EQUIPMENT WILL BE USED

RENTED AND/OR SOLD TO

Account #: 16374

Pryor Main Street
8 S. Vann
PRYOR, OK 74361

918-772-8251

WRITTEN BY	CHECKED IN BY	AGENT'S NAME	JOB LOCATION
Tonya	Tonya		
CAR LICENSE NO.	DRIVER'S LICENSE NUMBER	P.O. NO. OR JOB NO.	DATE AND TIME DUE IN
			04/22/2022 12:19 PM

ITEMS RENTED AND/OR SOLD

Item #	Description	Qty	Out / In	Rates	Days	Date&Time In	Amount
PS-001-01	Dunk Tank	0	1	24H 75.00	1	04/22/2022 11:08 AM	75.00
Quantity Rtn/AmtChgd: 1/ 75.00							

Thank you for choosing Midtown Rental
 *RETURN EQUIPMENT CLEAN, TO AVOID ADDITIONAL FEES
 *CUSTOMER IS RESPONSIBLE FOR ALL TIRE REPAIRS/DAMAGES
 *\$6.00/GAL FEE FOR ALL EQUIPMENT NOT RETURNED FULL
 *FOR RENTAL EQUIPMENT ISSUES, CALL US IMMEDIATELY OR WE CANNOT ADJUST YOUR TIME

DAMAGE WAIVER CHARGE (DWC) 10%

DWC IS NOT INSURANCE.

CC #: 0001 Approval: 274667

Total Rental	75.00
Environmental fee	1.13
Subtotal	76.13
Sales Tax (ST)	7.00
Total	83.13
Less Deposit	83.13
Balance Due	0.00

We greatly appreciate your business!!

Payment: CrCard

M&M Properties, LLC

22 South Adair Street
Pryor, OK 74361
(918) 630-1231
montylittlefield@gmail.co
m



INVOICE

BILL TO

Pryor Main Street
8 S. Vann St.
Pryor, Ok 74361

INVOICE # 1035

DATE 04/25/2022

DUE DATE 04/25/2022

ACTIVITY	DESCRIPTION	AMOUNT
Scope of Work	Labor and material for concrete, stamping, staining, and installation	5,545.00
Discount	Donated services	-1,045.00

We Appreciate Your Business.

Any 30 days overdue balances will accrue a monthly 6% late fee.

PAYMENT

4,500.00

BALANCE DUE

\$0.00

PAID



Party Perfect Event Rentals/Mershon
Events

How was your experience?



\$911.06

Custom Amount

\$911.06

Total

\$911.06

Party Perfect Event Rentals/Mershon Events

918-258-7368



Visa 7967 (On File)

Aug 6 2021 at 4:41 PM

VISA

#FghF

Auth code: 242123



6511 E 44th Street
 Tulsa, OK 74145
 www.partyprorents.com
 918-622-8102 Phone

Status: Quote

Quote #: q27728

Will Call: Tue 4/26/2022 8:00AM

Return: Thu 4/28/2022 2:00PM

Operator: Sarah Peschong

Customer #: 23271

Pryor Main Street, Inc

Phone 918-825-1095

PO Box 216

Job Descr: Monument

Pryor, OK 74362

Thank you for selecting Party Pro Rents!

Ordered By: Jennie

Salesman: Sarah Peschong sarah@partyprorents.com

CPU

Qty	Key	Items	Each	Status	Event End Date	Price	
30	31030	Chair Grey Plastic Folding	\$1.50	Rental	Thu 4/28/2022	\$45.00	
10	Linear Feet	Linear Feet of 10' Tall Pipe and Drape	\$6.50	Rental	Thu 4/28/2022	\$65.00	
If linear feet is under 50', customer is responsible for set up and breakdown. Arrangements can be made for set-up by Party Pro Rents for linear feet over 50' as long as a contact is onsite at time of delivery.							
2	B257DS	Upright 9'-16' Telescoping Pipe Slip Fit	\$0.00	Rental	Thu 4/28/2022	\$0.00	
2	B516	Base 24"x24" Slip Fit W/Pin	\$0.00	Rental	Thu 4/28/2022	\$0.00 /	
4	PremierBL10	Drape 10'T x 72"W Black Premier	\$0.00	Rental	Thu 4/28/2022	\$0.00	
1	draperodstelesco	Drape Rod 10-8-6 Adjustable	\$0.00	Rental	Thu 4/28/2022	\$0.00	
						Discount / Disc%	\$0.00 /
						Discount / Disc%	\$0.00 /

Please call to confirm Quote to a Reservation.

Quote

THIS IS NOT A RESERVATION. GUARANTEE PRODUCT AVAILABILITY FOR YOUR EVENT. RENTALS ARE ON A FIRST COME, FIRST SERVED BASIS. A NON-REFUNDABLE 25% DEPOSIT IS REQUIRED TO SECURE RENTALS FROM A QUOTE TO A RESERVATION. THERE WILL NOT BE A REFUND FOR ANY REASON INCLUDING A PANDEMIC AND GOVERNMENT SHUTDOWN. HOWEVER, WE WILL BE HAPPY TO MOVE YOUR EVENT DATE AND APPLY THE DEPOSIT TO A FUTURE EVENT DATE.

A QUOTE DOES NOT

Rental:	\$110.00
Damage Waiver:	\$13.20
Subtotal:	\$123.20
ja County (7281) 8.517%:	\$9.37
Total:	\$132.57
Paid:	\$0.00
Amount Due:	\$132.57



sam's club

Self Checkout

CLUB MANAGER BERNARD RUGGIERI
(918) 877 - 4546

04/19/22 10:41 9825 04839 096 9096

Putt

E	251870	COTTON CAND	7.72	E
E	251870	COTTON CAND	7.72	E
E	251870	COTTON CAND	7.72	E
E	251870	COTTON CAND	7.72	E
E	251870	COTTON CAND	7.72	E
E	251870	COTTON CAND	7.72	E
E	251870	COTTON CAND	7.72	E
E	251870	COTTON CAND	7.72	E
E	709743	AIRHEAD 90CF	11.84	E
E	709743	AIRHEAD 90CF	11.84	E
E	9949	CHARMS B/POF	11.12	E
E	53615	SKT TROP SHF	27.98	E
E	380414	HSV 3OCT UTF	22.82	E
E	990000374	SPK FUN SIZE	12.48	E
E	33408	COOKIE TRAYF	19.98	E
		SUBTOTAL	179.82	
		TOTAL	179.82	
		DEBIT TEND	179.82	
		CHANGE DUE	0.00	

EFT DEBIT PAY FROM PRIMARY
179.82 TOTAL PURCHASE
Debit **** * 5780 I 0
NETWORK ID. 0076 APPR CODE 131273

Debit
AID 80000000042203
AAC 773909A88904FD53
TERMINAL # SC010282

New! Free shipping for Plus members.
Learn more: samsclub.com/freeshipping
Visit samsclub.com to see your savings

ITEMS SOLD 15

TC# 5616 2993 0511 1997 0481 0



Fwd: Order Confirmation

1 message

Pryor Main Street <mainstreetpryor@gmail.com>
To: info.mainstreetpryor@gmail.com

Fri, Jul 15, 2022 at 12:19 PM

hotel/motel

----- Forwarded message -----

From: <copyprintsupport@staples.com>

Date: Sun, Apr 17, 2022 at 5:16 PM

Subject: Order Confirmation

To: <mainstreetpryor@gmail.com>



Hello Jennie

Thank you for choosing Staples. Below is the summary of your recent order. We will send you another email when it's ready for pickup.

Order Number: 6932141034

Order Date: Apr. 17th, 2022

Express Pickup: Ready by 11:00am on Apr. 19th

Store Pickup Items

Tulsa Store • 10302 East 71st South, Tulsa, OK, 74133

Pickup Person: Jennie Marlin

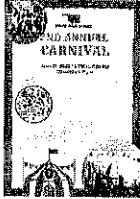

Carnival Flyer-2.pdf

Simple Print

Qty: 20
Price: \$12.76

No Binding • Single Sided • Color Ink • 24# Standard White



Store Wide Sale 25% off.pdf

Simple Print

Qty: 3
Price: \$11.48

No Binding • Single Sided • Color Ink • 110# Index White



Create Your Own Postcards

Qty: 50
Price: \$18.99

5.5x4.3 in • Gloss Stock

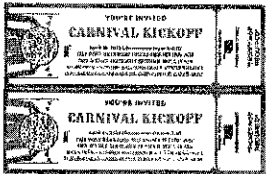

Create Your Own Postcards

Qty: 50
Price: \$18.99

5.5x4.3 in • Gloss Stock

Order Summary

Pickup Subtotal \$62.22

Express Pickup \$18.67

Estimated Tax

\$6.89

Order Total

\$87.78

Pickup Person Info

Pickup Person - Jennie Marlin

Phone - 9183731373

Email - mainstreetpryor@gmail.com

Payment Method

Your order was paid online. Please have a valid ID along with a copy of this order confirmation. Once pay online orders are produced, your credit card will be charged and you will receive a "Ready for Pick Up" notification email.

Need Help?

Call 1-888-333-3199



Maina Curtsinger <info.mainstreetpryor@gmail.com>

Fwd: Order Confirmation

Pryor Main Street <mainstreetpryor@gmail.com>
To: info.mainstreetpryor@gmail.com

Fri, Jul 15, 2022 at 12:20 PM

hotel/motel

----- Forwarded message -----

From: <copyprintsupport@staples.com>

Date: Thu, Nov 4, 2021 at 11:17 AM

Subject: Order Confirmation

To: <mainstreetpryor@gmail.com>



Hello Jennie

Thank you for choosing Staples. Below is the summary of your recent order.
We will send you another email when it's ready for pickup.

Order Number: 6930462638

Order Date: Nov. 4th, 2021

Store Pickup Items

Tulsa Store • 10302 East 71st South, Tulsa, OK, 74133

Pickup Person: Jennie Marlin



Lights on Downtown-2.png

Simple Print

Qty

Price

20

\$15.46

No Binding • Single Sided • True

Order Summary

Pickup Subtotal	\$15.46
Estimated Tax	\$1.32
Order Total	\$16.78

Pickup Person Info

Pickup Person - Jennie Marlin

Phone - 9183731373

Email - mainstreetpryor@gmail.com

Payment Method

Your order was paid online. Please have a valid ID along with a copy of this order confirmation. Once pay online orders are produced, your credit card will be charged and you will receive a "Ready for Pick Up" notification email.

Invoice from **The Sound**

 [Download PDF](#)

i The shipping and billing information are hidden from view to protect your privacy. Log in to view this invoice or ask the vendor for a PDF copy.



The Sound

Brady Salyers
1863 N. 4425 RD
Salina, OK 74365
UNITED STATES

 thesound74365@gmail.com

Bill to

ma*****@gmail.com

Items

Audio and lighting service DWTS

1 x \$1,200.00

\$1,200.00

Subtotal

\$1,200.00

Total

\$1,200.00

Invoice #0169
Issued : Aug 12, 2021
Due : Aug 12, 2021

Last updated on August 13, 2021 at 12:33:32 PM PDT

Balance due: \$0.0

Feedback

Original invoice total \$1,200.00

Total amount paid \$1,200.00

Payment activity

Payment - 8/13/21 \$1,200.00

Powered by  **PayPal**

Copyright © 1999–2022 PayPal. All rights reserved. [PayPal Privacy](#)



TRIBE CIRCUS ARTS

JILLIAN EDWARDS

Located in the Cross Creek Warehouses
12808 S. Memorial Dr., Unit 111, Bixby, OK 74008

PAID

RECEIPT #0135

PREPARED FOR

PRYOR MAIN STREET

Carnival event

PAID DATE
APRIL 22, 2022

ITEM	QTY	PRICE	TOTAL
Performance	2.5 HRS	\$140/hour	\$350

\$350



Claremore, OK 74018-0189
(855) 226-5722 | RCBbank.com
Member FDIC

Total Enclosed

12

Pryor Main Street Inc
8 S Vann
Pryor OK 74361

Checking Accounts

Account Title: Pryor Main Street Inc

Get Text Banking for free! Fraud detection made easy. No bank fees.
No hassle. No problem. Sign up today through our mobile banking app.
Standard carrier fees for text messaging may apply.

Corporate Free Checking
Account Number

XXXXXXXXXXXX7473

Images Enclosed

12

Statement Dates 8/02/21 thru 8/31/21

Days in the statement period 30

[Redacted]

[Redacted]

[Redacted]

[Redacted]

[Redacted]

[Redacted]

[Redacted]

[Redacted]

[Redacted]

Date 8/31/21
Primary Account
Total Enclosed

Page 3
XXXXXXXXXXXX7473
12

Corporate Free Checking

XXXXXXXXXXXX7473 (Continued)

Checks and Withdrawals

Date	Description	Amount
8/06	[REDACTED]	[REDACTED]
8/06	[REDACTED]	[REDACTED]
8/06	[REDACTED] CCD	[REDACTED]
8/06	[REDACTED]	[REDACTED]
8/09	[REDACTED]	[REDACTED]
8/09	[REDACTED]	[REDACTED]
8/09	DBT CRD 1900 08/06/21 26100602 SQ *PARTY PERFECT EVENT R gosq.comOK Card# 7967	911.06-
8/10	[REDACTED]	[REDACTED]
8/10	[REDACTED]	[REDACTED]
8/11	[REDACTED]	[REDACTED]
8/11	[REDACTED]	[REDACTED]
8/11	[REDACTED]	[REDACTED]
8/11	[REDACTED]	[REDACTED]
8/16	DBT CRD 1900 08/13/21 24852524 PAYPAL *SOUND 402-361-1111 Card# 7967	1,200.00-

Credit **Total Deposit**

Bank: RCB Bank
 Branch #: 4
 Branch Name: Pryor
 Teller ID: SANDI RSON1
 Drawer #: 428
 Trans #: 44
 Misc: 778 Commercial Dep.

Date/Time: [REDACTED]

SUBSTITUTE IMAGE / VIRTUAL DOCUMENT

AUXILIARY	R/T	ACCOUNT	PC/TC AMOUNT
[REDACTED]	[REDACTED]	[REDACTED]	[REDACTED]

Credit **Total Deposit**

Bank: RCB Bank
 Branch #: 4
 Branch Name: Pryor
 Teller ID: Idarnell
 Drawer #: 440
 Trans #: 58
 Misc: 778 Commercial Dep.

Date/Time: 08/24/2021 2:32 PM

SUBSTITUTE IMAGE / VIRTUAL DOCUMENT

AUXILIARY	R/T	ACCOUNT	PC/TC AMOUNT
[REDACTED]	[REDACTED]	[REDACTED]	[REDACTED]

Credit **Total Deposit**

Bank: RCB Bank
 Branch #: 4
 Branch Name: Pryor
 Teller ID: knaxton
 Drawer #: 434
 Trans #: 31
 Misc: 778 Commercial Dep.

Date/Time: [REDACTED]

SUBSTITUTE IMAGE / VIRTUAL DOCUMENT

AUXILIARY	R/T	ACCOUNT	PC/TC AMOUNT
[REDACTED]	[REDACTED]	[REDACTED]	[REDACTED]

Credit **Total Deposit**

Bank: RCB Bank
 Branch #: 4
 Branch Name: Pryor
 Teller ID: CWilson1
 Drawer #: 418
 Trans #: 178
 Misc: 778 Commercial Dep.

Date/Time: 08/24/2021 2:33 PM

SUBSTITUTE IMAGE / VIRTUAL DOCUMENT

AUXILIARY	R/T	ACCOUNT	PC/TC AMOUNT
[REDACTED]	[REDACTED]	[REDACTED]	[REDACTED]

Credit **Total Deposit**

Bank: RCB Bank
 Branch #: 4
 Branch Name: Pryor
 Teller ID: knaxton
 Drawer #: 434
 Trans #: 78
 Misc: 778 Commercial Dep.

Date/Time: [REDACTED]

SUBSTITUTE IMAGE / VIRTUAL DOCUMENT

AUXILIARY	R/T	ACCOUNT	PC/TC AMOUNT
[REDACTED]	[REDACTED]	[REDACTED]	[REDACTED]

Credit **Total Deposit**

Bank: RCB Bank
 Branch #: 4
 Branch Name: Pryor
 Teller ID: SANDI-RSON1
 Drawer #: 428
 Trans #: 83
 Misc: 778 Commercial Dep.

Date/Time: 08/24/2021 2:33 PM

SUBSTITUTE IMAGE / VIRTUAL DOCUMENT

AUXILIARY	R/T	ACCOUNT	PC/TC AMOUNT
[REDACTED]	[REDACTED]	[REDACTED]	[REDACTED]

Credit **Total Deposit**

Bank: RCB Bank
 Branch #: 4
 Branch Name: Pryor
 Teller ID: SANDI RSON1
 Drawer #: 428
 Trans #: 72
 Misc: 778 Commercial Dep.

Date/Time: [REDACTED]

SUBSTITUTE IMAGE / VIRTUAL DOCUMENT

AUXILIARY	R/T	ACCOUNT	PC/TC AMOUNT
[REDACTED]	[REDACTED]	[REDACTED]	[REDACTED]

Credit **Total Deposit**

Bank: RCB Bank
 Branch #: 4
 Branch Name: Pryor
 Teller ID: SANDI-RSON1
 Drawer #: 428
 Trans #: 82
 Misc: 778 Commercial Dep.

Date/Time: [REDACTED]

SUBSTITUTE IMAGE / VIRTUAL DOCUMENT

AUXILIARY	R/T	ACCOUNT	PC/TC AMOUNT
[REDACTED]	[REDACTED]	[REDACTED]	[REDACTED]

PRYOR MAIN STREET INC
 PO BOX 216
 8 S VANN ST PH 010-828-1006
 PRYOR OK 74801

1454
08-13/2021

Date: 8-5-21

Pay to the Order of: Maver County \$ 750.00
Seven hundred fifty Dollars

RCB BANK
 For: Event center

PRYOR MAIN STREET INC
 PO BOX 216
 8 S VANN ST PH 010-828-1006
 PRYOR OK 74801

1456
08-24/2021

Date: 8-20-21

Pay to the Order of: Ballman Designs \$ 676.00
Six hundred & seventy six dollars Dollars

RCB BANK
 For: T. Shirk

Check: 1454 Amount: \$750.00 Date: 8/13/2021

Check: 1456 Amount: \$676.00 Date: 8/24/2021

PRYOR MAIN STREET INC
 PO BOX 216
 8 S VANN ST PH 010-828-1006
 PRYOR OK 74801

1457
08-24/2021

[REDACTED]

PRYOR MAIN STREET INC
 PO BOX 216
 8 S VANN ST PH 010-828-1006
 PRYOR OK 74801

1458
08-24/2021

[REDACTED]

Date 11/30/21
Primary Account
Total Enclosed

Page 2
XXXXXXXXXXXX7473
5

Corporate Free Checking

XXXXXXXXXXXX7473 (Continued)

Checks and Withdrawals

Date Description Amount

[REDACTED]

11/05 DBI CRD 1900 11/05/21 26105127 16.78-
STAPLES 00111443
800-33333300K
Card# 7967

[REDACTED]

Corporate Free Checking XXXXXXXXXXXXX7473 (Continued)

Deposits and

[REDACTED]	[REDACTED]	[REDACTED]
[REDACTED]	22/03/08 CCD	[REDACTED]
[REDACTED]	[REDACTED]	[REDACTED]
[REDACTED]	22/03/14 CCD	[REDACTED]
3/28	Ch [REDACTED]	[REDACTED]
Ch [REDACTED]	[REDACTED]	[REDACTED]
Da [REDACTED]	[REDACTED]	[REDACTED]
3/01	[REDACTED]	[REDACTED]
[REDACTED]	[REDACTED]	[REDACTED]
3/02	9215986202 22/03/02 52477 [REDACTED] CCD	[REDACTED]
3/04	DBT CRD 1800 03/04/22 29000034 CANVA* 103349-21977426 HTTPSCANVA.CODE Card# 7967	12.99-
[REDACTED]	[REDACTED]	[REDACTED]
[REDACTED]	[REDACTED]	[REDACTED]
3/07	[REDACTED] SHO	24.00-
[REDACTED]	[REDACTED]	[REDACTED]
3/07	[REDACTED] 22/03/07 5 [REDACTED] CCD	[REDACTED]
[REDACTED]	[REDACTED]	[REDACTED]
[REDACTED]	[REDACTED]	[REDACTED]
3/08	[REDACTED] PPD	[REDACTED]
[REDACTED]	[REDACTED]	[REDACTED]
[REDACTED]	[REDACTED]	[REDACTED]
[REDACTED]	[REDACTED]	43.91-

Corporate Free Checking XXXXXXXXXXXX7473 (Continued)

Date	Description	Amount
4/11	[REDACTED] OF PRY.	[REDACTED]
4/11	[REDACTED] 01123	[REDACTED]
4/14	[REDACTED] 00565	[REDACTED]
4/14	[REDACTED]	[REDACTED]
4/19	[REDACTED]	[REDACTED]
4/20	[REDACTED]	[REDACTED]
4/20	[REDACTED]	[REDACTED]
4/22	[REDACTED] 67	[REDACTED]
4/22	[REDACTED] 28145295	[REDACTED]
4/22	DBT CRD 1900 04/21/22 27030026 MIDTOWN RENTAL SALES & SE CLAREMOREOK Card# 7967	88.13-
4/27	[REDACTED]	[REDACTED]
4/27	DBT CRD 1900 04/26/22 20900018 PARTY PRO RENTS 918-6228102OK Card# 7967	377.80-
	[REDACTED]	4.80-

RCB BANK *Don* **CHECKING WITHDRAWAL**
NOT NEGOTIABLE

ACCOUNT # [REDACTED] AMOUNT OF WITHDRAWAL [REDACTED]

Check: 0 Amount: [REDACTED]

Credit **Total Deposit**

Bank: [REDACTED] Date: 4/22/22 3:15 PM
Branch #: [REDACTED]
Drawer #: 431
Trans #: 100
Misc: [REDACTED]

SUBSTITUTE IMAGE / VIRTUAL DOCUMENT

Credit **Total Deposit**

Bank: RCB Bank
Branch #: 4
Branch Name: Pryor
Teller ID: DIXONG
Drawer #: 431
Trans #: 105
Misc: Ten Commercial Dep.

SUBSTITUTE IMAGE / VIRTUAL DOCUMENT

Check: 0 Amount: [REDACTED]

Credit **Total Deposit**

Bank: RCB Bank
Branch #: 4
Branch Name: Pryor
Teller ID: SANDI-RISON1
Drawer #: 428
Trans #: 7
Misc: Ten BIA Deposit

SUBSTITUTE IMAGE / VIRTUAL DOCUMENT

PRYOR MAIN STREET INC 1533
PO BOX 216 04-1254/1001
8 SWANN ST PH 818-825-1095
PRYOR OK 74361

4/20/22

Pay to the Order of: *M+M Properties* \$14500
four thousand five hundred 00/100 Dollars

RCB BANK
For: *Concrete - monument* *[Signature]*

Check: 1533 Amount: \$4,500.00 Date: 4/25/2022 Check Ck#1533

PRYOR MAIN STREET INC 1534
PO BOX 216 04-1254/1001
8 SWANN ST PH 818-825-1095
PRYOR OK 74361

4/21/22

Pay to the Order of: *Kristie's Twister* \$312.50
three hundred twelve 50/100 Dollars

RCB BANK
For: *Baloney* *[Signature]*

Check: 1534 Amount: \$312.50 Date: 4/22/2022 Check Ck#1534

PRYOR MAIN STREET INC 1535
PO BOX 216 04-1254/1001
8 SWANN ST PH 818-825-1095
PRYOR OK 74361

4/21/22

Pay to the Order of: *Jilliam Edwards* \$350
three hundred fifty dollars Dollars

RCB BANK
For: *Performance* *[Signature]*

Check: 1535 Amount: \$350.00 Date: 4/25/2022 Check Ck#1535

PRYOR MAIN STREET INC 1536
PO BOX 216 04-1254/1001
8 SWANN ST PH 818-825-1095
PRYOR OK 74361

[REDACTED]

RCB BANK

Check: 1536 Amount: [REDACTED] Date: [REDACTED] Check Ck#1536

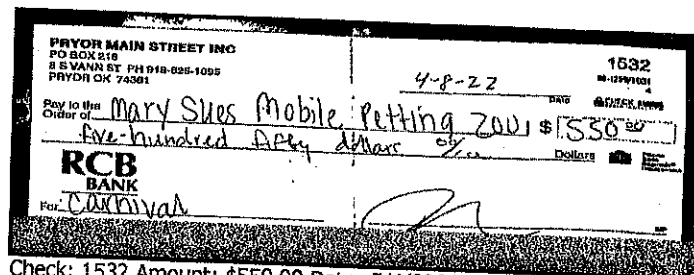
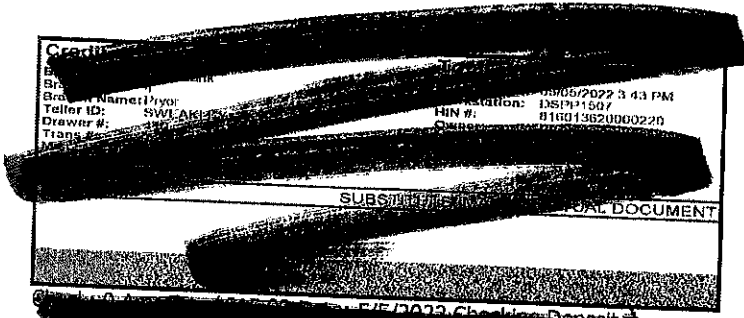

Check: 1532 Amount: \$550.00 Date: 5/4/2022 Check Ck#1532

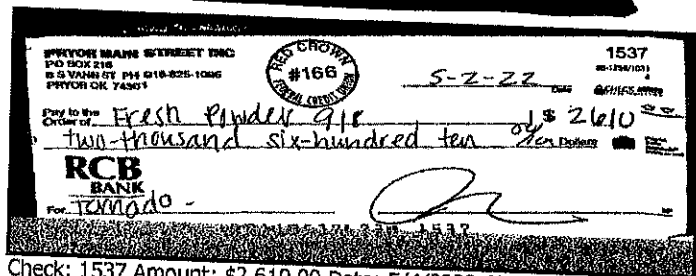

Check: 1537 Amount: \$2,610.00 Date: 5/4/2022 Check Ck#1537

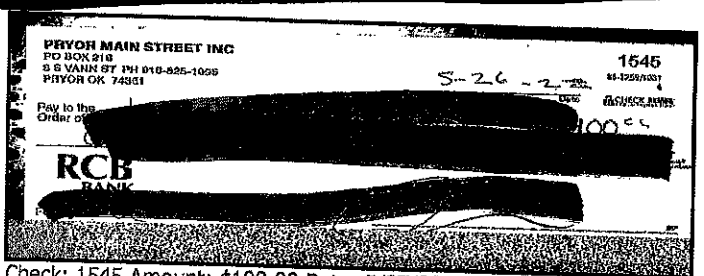
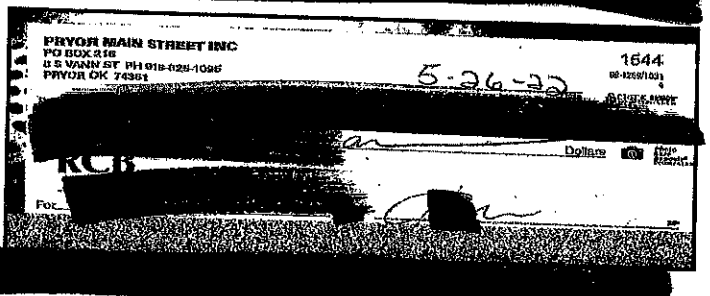
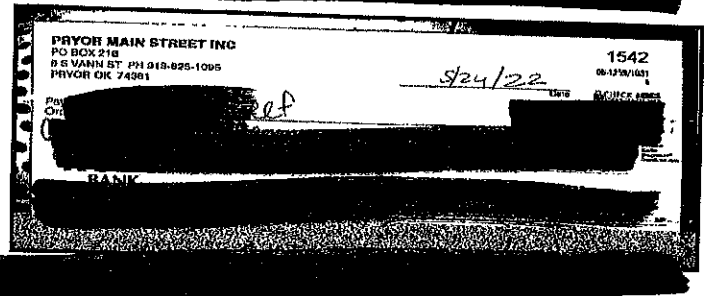
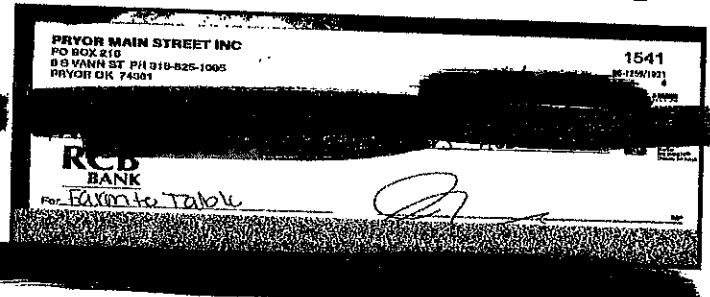
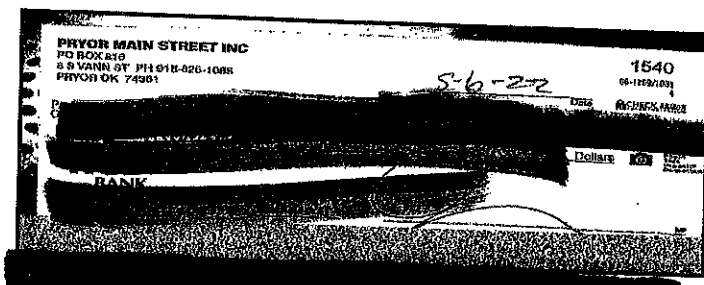
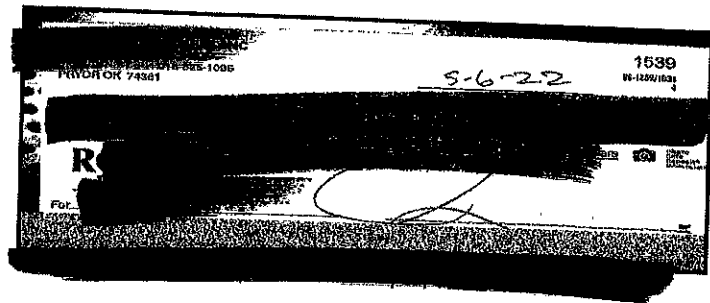

Check: 1545 Amount: \$100.00 Date: 5/27/2022 Check Ck#1545

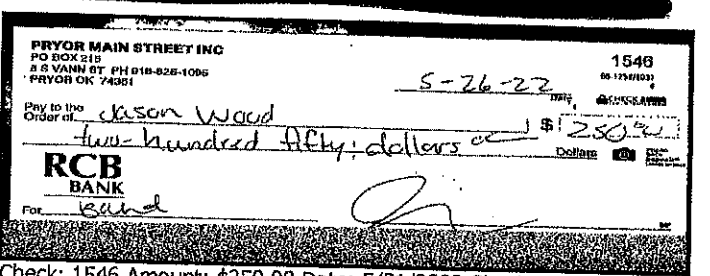

Check: 1546 Amount: \$250.00 Date: 5/31/2022 Check Ck#1546

RCB BANK CHECKING DEPOSIT

Bank Name: [REDACTED] Total Deposit: [REDACTED]

Branch: [REDACTED]

Branch Name: Pryor Teller ID: [REDACTED] Amount: \$481.00

Drawer #: [REDACTED] Amount: \$481.00

Trans #: [REDACTED] Amount: \$481.00

Min: [REDACTED]

NET DEPOSIT

Credit

Bank: [REDACTED] Total Deposit: [REDACTED]

Branch: [REDACTED]

Branch Name: Pryor Workstation: 74888

Teller ID: [REDACTED] Amount: \$500.00

Drawer #: [REDACTED] Amount: \$500.00

Trans #: [REDACTED] Amount: \$500.00

Min: [REDACTED]

IMAGE / VIRTUAL DOCUMENT

Credit

Branch Name: Pryor Total Deposit: [REDACTED]

Teller ID: [REDACTED] Amount: \$3,628.10

Drawer #: [REDACTED] Amount: \$3,628.10

Owner: Pryor Main Street Inc

Amount: \$3,628.10

SUBSTITUTE IMAGE / VIRTUAL DOCUMENT

PRYOR MAIN STREET INC

PO BOX 216 1538
 8 S VANN ST PH 010-825-1095
 PRYOR OK 74961 06-12/2021

Pay to the Order of: [REDACTED]

RCB BANK

Check: 1538 Amount: \$260.00 Date: 6/6/2022 Check Ck#1538

PRYOR MAIN STREET INC

PO BOX 216 1543
 8 S VANN ST PH 010-825-1095
 PRYOR OK 74961 06-12/2021

Pay to the Order of: Little Cabin Catenns

Two hundred dollars \$ 200.00

For: EATIN TO TABLE

Date: 6/3/22

RCB BANK

Check: 1543 Amount: \$200.00 Date: 6/3/2022 Check Ck#1543

PRYOR MAIN STREET INC

PO BOX 216 1547
 8 S VANN ST PH 010-825-1095
 PRYOR OK 74961 06-12/2021

Pay to the Order of: [REDACTED]

RCB BANK

PRYOR MAIN STREET INC

PO BOX 216 1548
 8 S VANN ST PH 010-825-1095
 PRYOR OK 74961 06-12/2021

Pay to the Order of: Ballman Designs

Three hundred fifty-five dollars and 95 cents \$ 355.95

For: SHIRTS

Date: 6/21/22

RCB BANK

Check: 1548 Amount: \$355.95 Date: 6/21/2022 Check Ck#1548

pacc
PRYOR AREA
CHAMBER OF COMMERCE

2021-2022 Hotel-Motel Allocation Expense Report

Amount Allocated 43,737.40
Expenses Submitted \$ 34,221.64

Remainder \$9,515.76

Allocated Funds for PACC Building Back Room Renovation \$9,889.65
Sound Abatement
CORI Project

-313.89

bacc
**PRYOR AREA
CHAMBER OF COMMERCE**

Pryor Area Chamber of Commerce
100 E. Graham Ave.
Pryor, OK 74361
918.825.0157
info@pryorchamber.com

CONFERENCES	\$	250.00
DIGITAL MEDIA SERVICES & MARKETING	\$	4,018.74
GREEN COUNTRY MARKETING	\$	4,351.00
HOTELS/MOTELS	\$	1,037.88
JEFFERSON HIGHWAY		\$1,416.75
LEAF - COPIER EQUIPMENT/SERVICE	\$	4,368.84
MEMBERCLICKS - PERSONIFY	\$	3,325.91
MISCELLANEOUS	\$	5,442.52
NORTHEAST OKLAHOMA REGIONAL ALLIANCE	\$	150.00
PRINT ADVERTISING	\$	5,360.00
SPONSORSHIPS	\$	4,500.00
TOTAL EXPENSES SUBMITTED	\$	34,221.64
TOTAL ALLOCATED		43,737.40
AMOUNT TO BE SPENT	\$	9,515.76

baac
PRYOR AREA
CHAMBER OF COMMERCE

Pryor Area Chamber of Commerce
100 E. Graham Ave.
Pryor, OK 74361
918.825.0157
info@pryorchamber.com

CONFERENCES

Check #	Payee	Description	Amount
	Green Country Tourism	2022 Annual Meeting	\$ 250.00
TOTAL			\$ 250.00



Green Country Tourism
2512 E 71st Street, Ste. G
Tulsa, OK 74136-5533

Invoice

Date	6/23/2022
Invoice #	12818

Bill To
Pryor Chamber of Commerce Barbara Hawkins PO Box 367 Pryor, OK 74362

Item Code	Description	Amount
Annual Meeting	Sapphire Sponsor Annual Meeting 2022 Includes 2 ticket for the meeting	250.00

Your partnership is appreciated.

Green Country Tourism
2512 E 71st Street, Suite G
Tulsa, OK 74136
918.744.0588
Admin@GreenCountryOk.com
Fed ID: 73-0931478

Total	\$250.00
Balance Due	\$250.00

baac
PRYOR AREA
CHAMBER OF COMMERCE

Pryor Area Chamber of Commerce
100 E. Graham Ave.
Pryor, OK 74361
918.825.0157
info@pryorchamber.com

DIGITAL MEDIA SERVICES & MARKETING

Check #	Payee	Description	Amount
18742	Business Card	Adobe Creative Cloud	\$ 19.99
18742	Business Card	Adobe	\$ 29.99
18742	Business Card	GoDaddy.com	\$ 19.17
18742	Business Card	Canva	\$ 12.95
18742	Business Card	Constant Contact	\$ 95.00
18742	Business Card	Adobe	\$ 29.99
18764	Business Card	Adobe Creative Cloud	\$ 29.99
18764	Business Card	Adobe	\$ 29.99
18764	Business Card	USPS	\$ 330.00
18764	Business Card	Canva	\$ 12.95
18764	Business Card	Constant Contact	\$ 95.00
18764	Business Card	Adobe	\$ 29.99
18780	Business Card	Adobe Creative Cloud	\$ 29.99
18780	Business Card	Adobe	\$ 29.99
18780	Business Card	Canva	\$ 12.95
18780	Business Card	Constant Contact	\$ 95.00
18780	Business Card	Adobe	\$ 29.99
18796	Business Card	Adobe Creative Cloud	\$ 29.99
18796	Business Card	Adobe	\$ 29.99
18796	Business Card	Canva	\$ 12.99

18796	Business Card	Constant Contact	\$ 95.00
18796	Business Card	Adobe	\$ 29.99
18814	Business Card	Adobe Creative Cloud	\$ 29.99
18814	Business Card	Adobe	\$ 29.99
18814	Business Card	GoDaddy.com	\$ 38.34
18814	Business Card	Canva	\$ 12.95
18814	Business Card	Wave HourlyCIO (Google Workspace)	\$ 216.00
18814	Business Card	Wave HourlyCIO (Google Workspace)	\$ 216.00
18814	Business Card	Constant Contact	\$ 95.00
18814	Business Card	Adobe	\$ 29.99
18833	Business Card	Adobe Creative Cloud	\$ 29.99
18833	Business Card	Adobe	\$ 29.99
18833	Business Card	Facebook	\$ 19.99
18833	Business Card	Content Marketing Bundle	\$ 200.00
18833	Business Card	Canva	\$ 12.95
18833	Business Card	Constant Contact	\$ 95.00
18833	Business Card	Adobe	\$ 29.99
18845	Business Card	Adobe Creative Cloud	\$ 29.99
18845	Business Card	Adobe	\$ 29.99
18845	Business Card	Canva	\$ 12.95
18845	Business Card	Adobe	\$ 29.99
18845	Business Card	Asknet Iobitsoft	\$ 65.87
18845	Business Card	Asknet Iobitsoft	\$ 6.58
18857	Business Card	Adobe Creative Cloud	\$ 29.99
18857	Business Card	Adobe	\$ 29.99
18857	Business Card	Microsoft	\$ 297.00
18857	Business Card	Canva	\$ 12.95
18857	Business Card	Adobe	\$ 29.99
18857	Business Card	SmileBox	\$ 47.88
18870	Business Card	Constant Contact	\$ 40.00
18870	Business Card	Adobe Creative Cloud	\$ 29.99
18870	Business Card	GoDaddy.com	\$ 80.68
18870	Business Card	Adobe	\$ 29.99
18870	Business Card	Facebook	\$ 6.27
18870	Business Card	Microsoft	\$ 54.99
18870	Business Card	Canva	\$ 12.95

18870	Business Card	Adobe	\$ 23.88
18870	Business Card	Adobe	\$ 29.99
18897	Business Card	Constant Contact	\$ 125.00
18897	Business Card	Adobe Creative Cloud	\$ 29.99
18897	Business Card	Adobe	\$ 29.99
18897	Business Card	Facebook	\$ 3.73
18897	Business Card	Canva	\$ 12.95
18897	Business Card	GoDaddy.com	\$ 30.16
18897	Business Card	Adobe	\$ 29.99
	Business Card	Constant Contact	\$ 125.00
	Business Card	Adobe Creative Cloud	\$ 29.99
	Business Card	Adobe	\$ 29.99
	Business Card	GoDaddy.com	\$ 30.16
	Business Card	USPS PO Boxes Online	\$ 70.00
	Business Card	USPS PO Boxes Online	\$ 160.00
	Business Card	Canva	\$ 12.95
	Business Card	Dropbox	\$ 119.88
	Business Card	Adobe	\$ 29.99
TOTAL			\$ 4,018.74

Transactions

Posting Date	Transaction Date	Description	Reference Number	Amount
08/09	08/07	PAYMENT - THANK YOU TOTAL PAYMENTS AND OTHER CREDITS FOR THIS PERIOD		
HAWKINS, BARBARA				
Account Number: 1774				
Purchases and Other Charges				
07/22	07/21	ADOBE CREATIVE CLOUD 4085366000 CA	52704871202700808336932	19.99
07/22	07/22	ADOBE *800-833-8687 ADOBE.LY/ENUSCA	55432861203200506408234	29.99
08/04	08/03	DNH*GODADDY.COM 480-5058855 AZ	75418231215127287286018	19.17
08/10	08/09	CANVA* I03142-26291282 CAMDEN DE	82305091221000016520340	12.95
08/16	08/14	EIG*CONSTANTCONTACT.CO 855-2295506 MA	75418231226128004707283	95.00
8	08/15	ADOBE *800-833-8687 ADOBE.LY/ENUSCA	55432861227200420487781	29.99

Finance Charge Calculation

Your Annual Percentage Rate (APR) is the annual interest rate on your account.

	Annual Percentage Rate	Balance Subject to Interest Rate	Finance Charges by Transaction Type
PURCHASES		\$0.00	\$0.00
CASH		\$0.00	\$0.00

V = Variable Rate (rate may vary), Promotional Balance = APR for limited time on specified transactions.

Reward Summary

Beginning Balance	
Earned	
Redeemed	.00
Adjustments	.00

To redeem your Cash Rewards call 1.800.673.1044, or visit www.bankofamerica.com

PRYOR AREA
CHAMBER OF COMMERCE, INC.

P.O. BOX 367
PRYOR, OK 74362

BUILDING A BETTER COMMUNITY TODAY - FOR TOMMORROW

RCB BANK

P.O. Box 8 Pryor, OK 74362
(918)825-4321 Member FDIC

018742

AY **** NINE HUNDRED SEVENTY THREE & 39/100 DOLLARS

TO THE
ORDER OF:

Business Card
PO Box 15796
Wilmington, DE 19886

DATE
09/10/21

AMOUNT
\$ **973.39

VOID AFTER 90 DAYS



AUTHORIZED SIGNATURE



⑈018742⑈ ⑆103112594⑆ 04000121004⑈

PRYOR AREA CHAMBER OF COMMERCE, INC.

018742

Vendor ID: BOFAMERICA

Name: Business Card
Check Date:
Check Amount:

09/10/21
973.39

MEMO:

Acct. # 5474976700308445

PRYOR AREA CHAMBER OF COMMERCE, INC.

018742

Vendor ID: BOFAMERICA

Name: Business Card
Check Date:
Check Amount:

09/10/21
973.39

MEMO:

Acct. # 5474976700308445

Transactions

Posting Date	Transaction Date	Description	Reference Number	Amount
HAWKINS, BARBARA				
Account Number: 1774				
Purchases and Other Charges				
08/23	08/21	ADOBE CREATIVE CLOUD 4085366000 CA	52704871233700889233902	29.99
08/23	08/22	ADOBE *800-833-6687 ADOBE.LY/ENUSCA	55432861234100449181406	29.99
08/24	08/23	USPS PO 3967320210 PRYOR OK	02305371236000540413142	330.00
09/15	09/14	EIG*CONSTANTCONTACT.CO 855-2295506 MA	75418231257130162398790	95.00
09/15	09/15	ADOBE *800-833-6687 ADOBE.LY/ENUSCA	55432861258200871985521	29.99
09/15	09/14	CANVA* I03173-32552338 CAMDEN DE	82305091252000016716080	12.95

Finance Charge Calculation

Your Annual Percentage Rate (APR) is the annual interest rate on your account.

	Annual Percentage Rate	Balance Subject to Interest Rate	Finance Charges by Transaction Type
PURCHASES			
CASH		\$0.00	\$0.00

V = Variable Rate (rate may vary), Promotional Balance = APR for limited time on specified transactions.

Important Messages

Returned Payment Fee

Effective August 20, 2021, you will no longer be assessed a fee for any payment on your Account that is returned to us unpaid.

PRYOR AREA
CHAMBER OF COMMERCE, INC.
P.O. BOX 367
PRYOR, OK 74362
BUILDING A BETTER COMMUNITY TODAY - FOR TOMORROW

RCB BANK
P.O. Box # Pryor, OK 74362
(918)972-6321 Member FDIC

018764

PAY **** TWO THOUSAND SEVEN HUNDRED TWENTY NINE & 50/100 DOLLARS
DATE 10/05/21 AMOUNT \$ **2729.58

TO THE ORDER OF: Business Card
PO Box 16786
Wilmington, DE 19886

VOID AFTER HOLDING
Cholka
AUTHORIZED SIGNATURE

0002 958312 10072021 1 8 0018
256783 3474976700208445 8K0GB56
RCB BANK OF AMERICA NA
604

13 Check 256783 10/7/2021 18 53 49 Sm Bus 15796 ZK0GB6L 62

CHECK HERE IF MOBILE DEPOSIT
DO NOT WRITE FROM THIS AREA FROM BANK

ENCLOSURE HERE

Transactions

Posting Date	Transaction Date	Description	Reference Number	Amount
10/08	10/07		2811530000000584503178	

TOTAL PAYMENTS AND OTHER CREDITS FOR THIS PERIOD

10/18 10/18

TOTAL FINANCE CHARGE FOR THIS PERIOD

HAWKINS, BARBARA
Account Number: 1774

Purchases and Other Charges

		ADOBE CREATIVE CLOUD 4085366000 CA	52704871264700568603534	29.99
		ADOBE *800-833-6687 ADOBE.LY/ENUSCA	55432861285200889010883	29.99
10/11	10/09	CANVA* 103203-22688701 CAMDEN DE	82305091282000017636166	12.95
10/15	10/14	EIG*CONSTANTCONTACT.CO 855-2295506 MA	75418231287132197295904	95.00
10/18	10/15	ADOBE *800-833-6687 ADOBE.LY/ENUSCA	55432861288200686512902	29.99

TOTAL PURCHASES AND OTHER CHARGES FOR THIS PERIOD

Finance Charge Calculation

Your Annual Percentage Rate (APR) is the annual interest rate on your account.

	Annual Percentage Rate	Balance Subject to Interest Rate	Finance Charges by Transaction Type
PURCHASES			
CASH		\$0.00	\$0.00

V = Variable Rate (rate may vary), Promotional Balance = APR for limited time on specified transactions.

Reward Summary

Beginning Balance		Other Bonuses
Earned		
Redeemed	.00	
Adjustments	.00	Ending Balance

To redeem your Cash Rewards call 1.800.673.1044, or visit www.bankofamerica.com

PRYOR AREA
CHAMBER OF COMMERCE, INC.

P.O. BOX 367
PRYOR, OK 74362

BUILDING A BETTER COMMUNITY TODAY - FOR TOMMORROW

018780

RCB BANK

P.O. Box 8 Pryor, OK 74362
(918)825-4321 Member FDIC

PAY **** NINE HUNDRED ELEVEN & 92/100 DOLLARS

TO THE
ORDER OF:

DATE

AMOUNT

11/04/21

\$

**911.92

Business Card
PO Box 15796
Wilmington, DE 19886

VOID AFTER 90 DAYS

Cholke

AUTHORIZED SIGNATURE



⑈018780⑈ ⑆103112594⑆ 04000121004⑈

PRYOR AREA CHAMBER OF COMMERCE, INC.

018780

Vendor ID: BOFAMERICA

Name: Business Card

Check Date:

11/04/21

Check Amount:

911.92

MEMO:

Acct. # 5474976700308445

Transactions

Posting Date	Transaction Date	Description	Reference Number	Amount
11/08	11/07		31115300000000546969115	

TOTAL PAYMENTS AND OTHER CREDITS FOR THIS PERIOD

HAWKINS, BARBARA
Account Number: 1774

Purchases and Other Charges

10/22	10/21	ADOBE CREATIVE CLOUD 4085366000 CA	52704871294700656016213	29.99
10/22	10/22	ADOBE *800-833-6687 ADOBE.LY/ENUSCA	55432861295200770500111	29.99

11/10	11/09	CANVA* I03234-35251206 CAMDEN DE	82305091313000012131265	12.95
11/15	11/14	EIG*CONSTANTCONTACT.CO 855-2295506 MA	75418231318134264587497	95.00
11/15	11/15	ADOBE *800-833-6687 ADOBE.LY/ENUSCA	55432861319200886986115	29.99

TOTAL PURCHASES AND OTHER CHARGES FOR THIS PERIOD

Finance Charge Calculation

Your Annual Percentage Rate (APR) is the annual interest rate on your account.

	Annual Percentage Rate	Balance Subject to Interest Rate	Finance Charges by Transaction Type
PURCHASES		\$0.00	\$0.00
CASH		\$0.00	\$0.00

V = Variable Rate (rate may vary), Promotional Balance = APR for limited time on specified transactions.

Important Messages

The United States Postal Service (USPS) began changing first class mail delivery timeframes in October. This change may result in mailed statements, new or replacement cards and payments you mail taking longer to arrive. For fast and easy access to your account information and to schedule payments 24/7 for your Bank of America credit card and loan accounts, use our Mobile Banking app and Online Banking digital solutions.

Mobile Banking requires that you download the Mobile Banking app and is only available for select mobile devices. Message and data rates may apply.

Reward Summary

Beginning Balance	
Earned	
Redeemed	.00
Adjustments	.00

To redeem your Cash Rewards call 1.800.673.1044, or visit www.bankofamerica.com

PRYOR AREA
CHAMBER OF COMMERCE, INC.

P.O. BOX 367
PRYOR, OK 74362

BUILDING A BETTER COMMUNITY TODAY - FOR TOMMORROW

RCB BANK

P.O. Box 8 Pryor, OK 74362
(918)825-4321 Member FDIC

018796

Y **** NINE HUNDRED FIFTY & 8/100 DOLLARS

TO THE
ORDER OF:

DATE

AMOUNT

12/07/21

\$

**950.08

Business Card
PO Box 15796
Wilmington, DE 19886

VOID AFTER 90 DAYS

[Handwritten Signature]

AUTHORIZED SIGNATURE



⑈018796⑈ ⑆103112594⑆ 04000121004⑈

PRYOR AREA CHAMBER OF COMMERCE, INC.

018796

Vendor ID: BOFAMERICA

Name: Business Card
Check Date:
Check Amount:

12/07/21
950.08

MEMO:

Acct. # 5474976700308445

PRYOR AREA CHAMBER OF COMMERCE, INC.

018796

Vendor ID: BOFAMERICA

Name: Business Card
Check Date:
Check Amount:

12/07/21
950.08

MEMO:

Acct. # 5474976700308445

(1)

PRYOR AREA CHMBR OF COMM

November 19, 2021 - December 18, 2021

Page 3 of 4

Transactions

Posting Date	Transaction Date	Description	Reference Number	Amount
12/15	12/11	PAYMENT - THANK YOU	3491530000000518629107	
TOTAL PAYMENTS AND OTHER CREDITS FOR THIS PERIOD				

HAWKINS, BARBARA
Account Number: 1774

Purchases and Other Charges

11/22	11/21	ADOBE CREATIVE CLOUD 4085366000 CA	52704871325700747201132	29.99
11/22	11/22	ADOBE *800-833-6687 ADOBE.LY/ENUSCA	55432861326200039973888	29.99
11/29	11/28	DNH*GODADDY.COM 480-5058855 AZ	75418231330135108155544	38.34
12/10	12/09	CANVA*103264-35419633 CAMDEN DE	82305091343000013289066	12.95
12/14	12/13	WAVE - *HOURLYCIO 317-4260411 IN	75418231347136397650808	216.00
12/14	12/13	WAVE - *HOURLYCIO 317-4260411 IN	75418231347136396548920	216.00
12/15	12/14	EIG*CONSTANTCONTACT.CO 855-2295506 MA	75418231348136436663423	95.00
12/15	12/15	ADOBE *800-833-6687 ADOBE.LY/ENUSCA	55432861349200619160545	29.99
TOTAL PURCHASES AND OTHER CHARGES FOR THIS PERIOD				\$1,251.43

Finance Charge Calculation

Your Annual Percentage Rate (APR) is the annual interest rate on your account.

	Annual Percentage Rate	Balance Subject to Interest Rate	Finance Charges by Transaction Type
PURCHASES	27.99%	\$0.00	\$0.00
CASH	26.24% V	\$0.00	\$0.00

V = Variable Rate (rate may vary), Promotional Balance = APR for limited time on specified transactions.

Reward Summary

Beginning Balance	1,101.21	Other Bonuses	4.48
Earned	12.16		
Redeemed	.00		
Adjustments	.00	Ending Balance	1,117.85

To redeem your Cash Rewards call 1.800.673.1044, or visit www.bankofamerica.com

PRYOR AREA
CHAMBER OF COMMERCE, INC.

P.O. BOX 367
PRYOR, OK 74362

BUILDING A BETTER COMMUNITY TODAY - FOR TOMMORROW

RCB BANK

P.O. Box 8 Pryor, OK 74362
(918)825-4321 Member FDIC

018814

**** ONE THOUSAND TWO HUNDRED FIFTY ONE & 43/100 DOLLARS

TO THE
ORDER OF:

DATE

AMOUNT

01/03/22

\$

**1251.43

Business Card
PO Box 15796
Wilmington, DE 19886

VOID AFTER 90 DAYS

AUTHORIZED SIGNATURE



⑈018814⑈ ⑆103112594⑆ 04000121004⑈

PRYOR AREA CHAMBER OF COMMERCE, INC.

018814

Vendor ID: BOFAMERICA

Name: Business Card

Check Date:

01/03/22

Check Amount:

1,251.43

MEMO:

Acct. # 5474976700308445

PRYOR AREA CHAMBER OF COMMERCE, INC.

018814

Vendor ID: BOFAMERICA

Name: Business Card

Check Date:

01/03/22

Check Amount:

1,251.43

MEMO:

Acct. # 5474976700308445

Transactions

Posting Date	Transaction Date	Description	Reference Number	Amount
01/11	01/08	PAYMENT - THANK YOU	01115300000000572804320	
TOTAL PAYMENTS AND OTHER CREDITS FOR THIS PERIOD				
HAWKINS, BARBARA				
Account Number: 1774				
Purchases and Other Charges				
12/22	12/21	ADOBE CREATIVE CLOUD 4085366000 CA	52704871355700836575969	29.99
12/22	12/22	ADOBE *800-833-6687 ADOBE.LY/ENUSCA	55432861356200007350229	29.99
01/03	12/31	FACEBK 7A6VKATXQ2 Menlo Park CA	15270211365000103813633	19.99
01/06	01/05	CONTENT MARKETING BUND ALLYN WA	82711162006000002466977	200.00
01/10	01/09	CANVA* I03295-21824919 CAMDEN DE	82305092009000011933270	12.95
01/17	01/14	EIG*CONSTANTCONTACT.CO 855-2295506 MA	75418232014138533668264	95.00
01/17	01/15	ADOBE *800-833-6687 ADOBE.LY/ENUSCA	55432862015200903329229	29.99
TOTAL PURCHASES AND OTHER CHARGES FOR THIS PERIOD				

Finance Charge Calculation

Your Annual Percentage Rate (APR) is the annual interest rate on your account.

	Annual Percentage Rate	Balance Subject to Interest Rate	Finance Charges by Transaction Type
PURCHASES		\$0.00	\$0.00
CASH		\$0.00	\$0.00

V = Variable Rate (rate may vary), Promotional Balance = APR for limited time on specified transactions.

Important Messages

YOUR FINANCE CHARGES IN 2021 WERE

Reward Summary

Beginning Balance		Other Bonuses
Earned		
Redeemed	.00	
Adjustments	.00	Ending Balance

To redeem your Cash Rewards call 1.800.673.1044, or visit www.bankofamerica.com

PRYOR AREA
CHAMBER OF COMMERCE, INC.

P.O. BOX 367
PRYOR, OK 74362

BUILDING A BETTER COMMUNITY TODAY - FOR TOMMORROW

RCB BANK

P.O. Box 8 Pryor, OK 74362
(918)825-4321 Member FDIC

018833

Y ***** ONE THOUSAND ONE HUNDRED FIFTEEN & 0/100 DOLLARS

TO THE
ORDER OF:

DATE 02/02/22 AMOUNT \$ **1115.00

Business Card
PO Box 15796
Wilmington, DE 19886

VOID AFTER 90 DAYS

AUTHORIZED SIGNATURE



⑈018833⑈ ⑆103112594⑆ 04000121004⑈

PRYOR AREA CHAMBER OF COMMERCE, INC.

018833

Vendor ID: BOFAMERICA

Name: Business Card

Check Date: 02/02/22

Check Amount: 1,115.00

MEMO:

Acct. # 5474976700308445

PRYOR AREA CHAMBER OF COMMERCE, INC.

018833

Vendor ID: BOFAMERICA

Name: Business Card

Check Date: 02/02/22

Check Amount: 1,115.00

MEMO:

Acct. # 5474976700308445

Transactions

Posting Date	Transaction Date	Description	Reference Number	Amount
02/10	02/09	PAYMENT - THANK YOU	0411530000000531119053	
TOTAL PAYMENTS AND OTHER CREDITS FOR THIS PERIOD				

HAWKINS, BARBARA
Account Number: 1774

Posting Date	Transaction Date	Description	Reference Number	Amount
01/31	01/29	TOTAL PAYMENTS AND OTHER CREDITS FOR THIS PERIOD		
Purchases and Other Charges				

01/24	01/21	ADOBE CREATIVE CLOUD 4085366000 CA	52704872021700529499131	29.99
01/24	01/22	ADOBE *800-833-6687 ADOBE.LY/ENUSCA	55432862022200905234683	29.99

02/10	02/09	CANVA* I03326-36316483 CAMDEN DE	82305092040000017180562	12.95
02/15	02/15	ADOBE *800-833-6687 ADOBE.LY/ENUSCA	55432862046200892456036	29.99

02/17	02/16	ASKNET *IOBITSOFT 415-423-2165 CA	55432862047200352533042	65.87
02/17	02/16	ASKNET *IOBITSOFT 415-423-2165 CA	55432862047200352533059	6.58
TOTAL PURCHASES AND OTHER CHARGES FOR THIS PERIOD				

Finance Charge Calculation

Annual Percentage Rate (APR) is the annual interest rate on your account.

	Annual Percentage Rate	Balance Subject to Interest Rate	Finance Charges by Transaction Type
PURCHASES		\$0.00	\$0.00
CASH		\$0.00	\$0.00

V = Variable Rate (rate may vary), Promotional Balance = APR for limited time on specified transactions.

Important Messages

YOUR FINANCE CHARGES IN 2021 WERE

Reward Summary

Beginning Balance		Other Bonuses
Earned		
Redeemed	.00	
Adjustments	.00	Ending Balance

To redeem your Cash Rewards call 1.800.673.1044, or visit www.bankofamerica.com

PRYOR AREA
CHAMBER OF COMMERCE, INC.

P.O. BOX 367
PRYOR, OK 74362

BUILDING A BETTER COMMUNITY TODAY - FOR TOMMORROW

RCB BANK
P.O. Box 8 Pryor, OK 74362
(918)825-4321 Member FDIC

018845

AY ***** ONE THOUSAND ONE HUNDRED SEVENTY SEVEN & 55/100 DOLLARS

TO THE
ORDER OF:

DATE

AMOUNT

03/08/22

\$

**1177.55

Business Card
PO Box 15796
Wilmington, DE 19886

VOID AFTER 90 DAYS

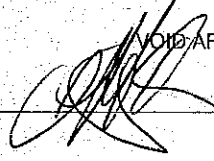

AUTHORIZED SIGNATURE



⑈018845⑈ ⑆103112594⑆ 04000121004⑈

PRYOR AREA CHAMBER OF COMMERCE, INC.

018845

Vendor ID: BOFAMERICA

Name: Business Card

Check Date:

03/08/22

Check Amount:

1,177.55

MEMO:

Acct. # 5474976700308445

PRYOR AREA CHAMBER OF COMMERCE, INC.

018845

Vendor ID: BOFAMERICA

Name: Business Card

Check Date:

03/08/22

Check Amount:

1,177.55

MEMO:

Acct. # 5474976700308445

Cardholder Activity Summary

Account Number Credit Limit	Total Activity	Payments and Other Credits	Balance Transfer Activity	Cash Advance Activity	Purchases and Other Charges	Fees Charged
HAWKINS BARBARA		0.00	0.00	0.00		0.00

Transactions

Posting Date	Transaction Date	Description	Reference Number	Amount
PRYOR AREA CHMBR OF COMM				
Account Number: 8445				
Payments and Other Credits				
03/11	03/10	PAYMENT - THANK YOU	07015300000000590765428	
TOTAL PAYMENTS AND OTHER CREDITS FOR THIS PERIOD				

HAWKINS, BARBARA				
Account Number: 1774				
Purchases and Other Charges				
02/22	02/21	ADOBE CREATIVE CLOUD 4085366000 CA	52704872052700620571699	29.99
02/22	02/22	ADOBE *800-833-6687 ADOBE.LY/ENUSCA	55432862053200927494473	29.99
02/28	02/26	MSFT * E0600HQOW0 MSBILL.INFO WA	15270212057000012463729	297.00
03/10	03/09	CANVA* I03354-35630174 CAMDEN DE	82305092068000014937474	12.95
03/15	03/15	ADOBE *800-833-6687 ADOBE LY/FNIUSCA	55432862074200418728764	29.99
03/17	03/17	SMILEBOX SMILEBOX.COM 360-797-5269 WA	55432862076200040666398	47.88
TOTAL PURCHASES AND OTHER CHARGES FOR THIS PERIOD				

Finance Charge Calculation

Your Annual Percentage Rate (APR) is the annual interest rate on your account.

	Annual Percentage Rate	Balance Subject to Interest Rate	Finance Charges by Transaction Type
PURCHASES		\$0.00	\$0.00
CASH		\$0.00	\$0.00

V = Variable Rate (rate may vary), Promotional Balance = APR for limited time on specified transactions.

Reward Summary

Beginning Balance		Other Bonuses
Earned		
Redeemed	.00	
Adjustments	.00	Ending Balance

To redeem your Cash Rewards call 1.800.673.1044, or visit www.bankofamerica.com

PRYOR AREA
CHAMBER OF COMMERCE, INC.

P.O. BOX 367
PRYOR, OK 74362

BUILDING A BETTER COMMUNITY TODAY - FOR TOMMORROW

RCB BANK

P.O. Box 8 Pryor, OK 74362
(918)825-4321 Member FDIC

018857

AY **** ONE THOUSAND TWO HUNDRED EIGHTY NINE & 6/100 DOLLARS

TO THE
ORDER OF:

DATE

AMOUNT

04/06/22

\$

**1289.06

Business Card
PO Box 15796
Wilmington, DE 19886

VOID AFTER 90 DAYS

Cholke

AUTHORIZED SIGNATURE



⑈018857⑈ ⑆103112594⑆ 04000121004⑈

PRYOR AREA CHAMBER OF COMMERCE, INC.

018857

Vendor ID: BOFAMERICA

Name: Business Card

Check Date:

04/06/22

Check Amount:

1,289.06

MEMO:

Acct. # 5474976700308445

PRYOR AREA CHAMBER OF COMMERCE, INC.

018857

Vendor ID: BOFAMERICA

Name: Business Card

Check Date:

04/06/22

Check Amount:

1,289.06

MEMO:

Acct. # 5474976700308445

Transactions

Posting Date	Transaction Date	Description	Reference Number	Amount
04/11	04/10	PAYMENT - THANK YOU	10015300000000551705383	
TOTAL PAYMENTS AND OTHER CREDITS FOR THIS PERIOD				
HAWKINS, BARBARA				
Account Number: 1774				
Purchases and Other Charges				
03/21	03/19	EIG*CONSTANTCONTACT.CO 855-2295506 MA	75418232078143054981438	40.00
03/22	03/21	ADOBE CREATIVE CLOUD 4085366000 CA	52704872080700713365245	29.99
03/22	03/21	DNH*GODADDY.COM 480-5058855 AZ	75418232080143188115495	80.68
03/22	03/22	ADOBE *800-833-6687 ADOBE.LY/ENUSCA	55432862081200528957510	29.99
03/31	03/31	FACEBK S65BJKXQ2 Menlo Park CA	15270212090000210893635	6.27
04/05	04/04	MS OFFICE STORE LONDON LND	85383902094000007400346	54.99
04/11	04/09	CANVA* I03385-23947429 CAMDEN DE	82305092099000015500040	12.95
04/11	04/10	ADOBE *800-833-6687 ADOBE.LY/ENUSCA	55432862100200311973085	23.88
04/15	04/15	ADOBE *800-833-6687 ADOBE.LY/ENUSCA	55432862105200833518728	29.99
TOTAL PURCHASES AND OTHER CHARGES FOR THIS PERIOD				
Fees Charged				
04/05	04/05	INTERNATIONAL TRANSACTION FEE	85383902094000007400346	
TOTAL FEES FOR THIS PERIOD				

Finance Charge Calculation

Your Annual Percentage Rate (APR) is the annual interest rate on your account.

	Annual Percentage Rate	Balance Subject to Interest Rate	Finance Charges by Transaction Type
PURCHASES		\$0.00	\$0.00
CASH		\$0.00	\$0.00

V = Variable Rate (rate may vary), Promotional Balance = APR for limited time on specified transactions.

Reward Summary

Beginning Balance		Other Bonuses
Earned		
Redeemed	.00	
Adjustments	.00	Ending Balance

To redeem your Cash Rewards call 1.800.673.1044, or visit www.bankofamerica.com

PRYOR AREA
CHAMBER OF COMMERCE, INC.

P.O. BOX 367
PRYOR, OK 74362

BUILDING A BETTER COMMUNITY TODAY - FOR TOMMORROW

018870

RCB BANK

P.O. Box 8 Pryor, OK 74362
(918)825-4321 Member FDIC

PAY **** NINE HUNDRED SEVEN & 75/100 DOLLARS

TO THE
ORDER OF:

Business Card
PO Box 15796
Wilmington, DE 19886

DATE 04/27/22 AMOUNT \$ **907.75

VOID AFTER 90 DAYS

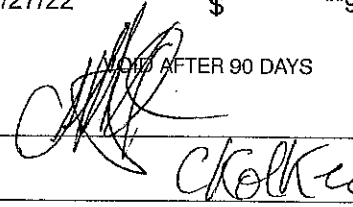

AUTHORIZED SIGNATURE



⑈018870⑈ ⑆103112594⑆ 04000121004⑈

PRYOR AREA CHAMBER OF COMMERCE, INC.

018870

Vendor ID: BOFAMERICA

Name: Business Card

Check Date:

04/27/22

Check Amount:

907.75

MEMO:

Acct. # 5474976700308445

PRYOR AREA CHAMBER OF COMMERCE, INC.

018870

Vendor ID: BOFAMERICA

Name: Business Card

Check Date:

04/27/22

Check Amount:

907.75

MEMO:

Acct. # 5474976700308445

PRYOR AREA CHMBR OF COMM

April 19, 2022 - May 18, 2022
Page 3 of 6

Transactions

Posting Date	Transaction Date	Description	Reference Number	Amount
05/02	05/02	PAYMENT - THANK YOU	1221530000000591148440	
TOTAL PAYMENTS AND OTHER CREDITS FOR THIS PERIOD				

HAWKINS, BARBARA
Account Number: 1774

Purchases and Other Charges				
04/20	04/19	EIG*CONSTANTCONTACT.CO 855-2295506 MA	75418232109145272754417	125.00
04/22	04/21	ADOBE CREATIVE CLOUD 4085366000 CA	52704872111/0080/922441	29.99
04/25	04/22	ADOBE *800-833-6687 ADOBE.LY/ENUSCA	55432862112200995462351	29.99
05/02	04/30	FACEBK H86GTEPXQ2 Menlo Park CA	15270212120000036513627	3.73
05/10	05/09	CANVA* I03415-19691920 CAMDEN DE	82305092129000013790277	12.95
05/16	05/13	DNH*GODADDY.COM 4805058855 AZ	55131582134400909159182	30.16
05/16	05/15	ADOBE *800-833-6687 ADOBE.LY/ENUSCA	55432862135200229214670	29.99
TOTAL PURCHASES AND OTHER CHARGES FOR THIS PERIOD				

Finance Charge Calculation

Your Annual Percentage Rate (APR) is the annual interest rate on your account.

	Annual Percentage Rate	Balance Subject to Interest Rate	Finance Charges by Transaction Type
PURCHASES		\$0.00	\$0.00
CASH		\$0.00	\$0.00

V = Variable Rate (rate may vary). Promotional Balance = APR for limited time on specified transactions.

Reward Summary

Beginning Balance		Other Bonuses
Earned		
Redeemed	.00	
Adjustments	.00	Ending Balance

To redeem your Cash Rewards call 1.800.673.1044, or visit www.bankofamerica.com

PRYOR AREA
CHAMBER OF COMMERCE, INC.

P.O. BOX 367
PRYOR, OK 74362

BUILDING A BETTER COMMUNITY TODAY - FOR TOMMORROW

RCB BANK

P.O. Box 8 Pryor, OK 74362
(918)825-4321 Member FDIC

018897

Y **** ONE THOUSAND THREE HUNDRED NINETY NINE & 55/100 DOLLARS

TO THE
ORDER OF:

DATE

AMOUNT

06/07/22

\$

**1399.55

VOID AFTER 90 DAYS

Business Card
PO Box 15796
Wilmington, DE 19886



AUTHORIZED SIGNATURE



⑈018897⑈ ⑆103112594⑆ 04000121004⑈

PRYOR AREA CHAMBER OF COMMERCE, INC.

018897

Vendor ID: BOFAMERICA

Name: Business Card

Check Date:

06/07/22

Check Amount:

1,399.55

MEMO:

Acct. # 5474976700308445

PRYOR AREA CHAMBER OF COMMERCE, INC.

018897

Vendor ID: BOFAMERICA

Name: Business Card

Check Date:

06/07/22

Check Amount:

1,399.55

MEMO:

Acct. # 5474976700308445

TRANSACTIONS

Posting Date	Transaction Date	Description	Reference Number	Amount
06/13	06/12	PAYMENT - THANK YOU	1641530000000571332179	
TOTAL PAYMENTS AND OTHER CREDITS FOR THIS PERIOD				

HAWKINS, BARBARA
Account Number: 1774

Purchases and Other Charges				
05/20	05/19	EIG*CONSTANTCONTACT.CO 855-2295506 MA	75418232139147634364749	125.00
05/23	05/21	ADOBE CREATIVE CLOUD 4085366000 CA	52704872141700507491020	29.99
05/23	05/22	ADOBE *800-833-6687 ADOBE.LY/ENUSCA	55432862142200425893732	29.99
05/30	05/27	DNH*GODADDY.COM 480-505-8855 AZ	55432862147200194294612	30.16
06/10	06/09	CANVA* I03446-28505555 CAMDEN DE	82305092160000015190864	12.95
06/15	06/15	DROPBOX*T63Z5X9XTSM3 DROPBOX.COM CA	55432862166200901227851	119.88
06/15	06/15	ADOBE *800-833-6687 ADOBE.LY/ENUSCA	55432862166200918573867	29.99

Your Annual Percentage Rate (APR) is the annual interest rate on your account

	Annual Percentage Rate	Balance Subject to Interest Rate	Finance Charges by Transaction Type
PURCHASES		\$0.00	\$0.00
CASH		\$0.00	\$0.00

V = Variable Rate (rate may vary) Promotional Balance = APR for limited time on specified transactions

Beginning Balance		Other Bonuses
Earned		
Redeemed	.00	
Adjustments	.00	Ending Balance

To redeem your Cash Rewards call 1.800.673.1044 or visit www.bankofamerica.com

bacc
PRYOR AREA
CHAMBER OF COMMERCE

Pryor Area Chamber of Commerce
100 E. Graham Ave.
Pryor, OK 74361
918.825.0157
info@pryorchamber.com

GREEN COUNTRY MARKETING

Check #	Payee	Description	Amount
18767	Green Country Tourism	1/2 Page Ad - 2022 Guide to Green Country	\$ 2,211.00
18818	Green Country Tourism	2022 Membership Investment	\$ 350.00
18818	Green Country Tourism	Christmas Luncheon	\$ 10.00
18849	Green Country Tourism	Green Country Publications (w/co-ops)	\$ 1,780.00
TOTAL			\$ 4,351.00

Green Country Tourism
2512 E 71st Street, Ste. G
Tulsa, OK 74136-5533

Phone #918-744-0588

Invoice

Date	10/5/2021
Invoice #	10/5/2021

Bill To
Pryor Chamber of Commerce Barbara Hawkins PO Box 367 Pryor, OK 74362

acct # 125000

Item Code	Description	Amount
1/2 Page	1/2 Page Ad: Guide to Green Country 2022	2,211.00

Thank you for your participation. We appreciate you.

Green Country Tourism, 2512 E. 71st Street, Ste G,
Tulsa, OK 74136
Phone #: 73-0931478

Total	\$2,211.00
Balance Due	\$2,211.00

PRYOR AREA
CHAMBER OF COMMERCE, INC.
P.O. BOX 367
PRYOR, OK 74362

BUILDING A BETTER COMMUNITY TODAY - FOR TOMMORROW

RCB BANK
P.O. Box 8 Pryor, OK 74362
(918)825-4321 Member FDIC

018767

**** TWO THOUSAND TWO HUNDRED ELEVEN & 0/100 DOLLARS

TO THE
ORDER OF:

DATE
10/13/21

AMOUNT
\$ **2211.00

Green Country Tourism
2512 E 71st Street Ste G
Tulsa, OK 74136-5533

VOID AFTER 90 DAYS

CKolker

AUTHORIZED SIGNATURE



⑈018767⑈ ⑆103112594⑆ 04000121004⑈

PRYOR AREA CHAMBER OF COMMERCE, INC.

018767

Vendor ID: GC TOURISM

Name: Green Country Tourism
Check Date: 10/13/21
Check Amount: 2,211.00

MEMO:

Invoice #10/5/2021

PRYOR AREA CHAMBER OF COMMERCE, INC.

018767

Vendor ID: GC TOURISM

Name: Green Country Tourism
Check Date: 10/13/21
Check Amount: 2,211.00

MEMO:

Invoice #10/5/2021



Green Country Tourism
 2512 E 71st Street, Ste. G
 Tulsa, OK 74136-5533

Invoice

Date	12/22/2021
Invoice #	12/22/2021

Bill To
Pryor Chamber of Commerce Barbara Hawkins PO Box 367 Pryor, OK 74362

Item Code	Description	Amount
Membership	Membership Investment - Green Country Marketing Association is a non-profit, private sector, tourism marketing association. Federal tax exempt under IRS Code 501c6 Number 73-0931478. Membership investment is a tax deductible business expense.	350.00
<div data-bbox="522 1602 1076 1703" data-label="Text"> <p>Thank you for your participation. We appreciate you.</p> </div>		

Green Country Tourism
 2512 E. 71st Street, Ste. G
 Tulsa, OK 74136

Fed ID# 73-0931478

918-744-0588

Admin@GreenCountryOk.com

Total	\$350.00
Balance Due	\$350.00



Green Country Tourism
 2512 E 71st Street, Ste. G
 Tulsa, OK 74136-5533

Invoice

Date	12/22/2021
Invoice #	12/22/2021

Bill To
Pryor Chamber of Commerce Barbara Hawkins PO Box 367 Pryor, OK 74362
Account # 126750

Item Code	Description	Amount
Misc Admin	Christmas luncheon	10.00
<div data-bbox="516 1575 1068 1675" data-label="Text"> <p>Thank you for your participation. We appreciate you.</p> </div>		

Green Country Tourism
 2512 E. 71st Street, Ste. G
 Tulsa, OK 74136

Phone ID#: 73-0931478

918-744-0588

Admin@GreenCountryOk.com

Total	\$10.00
Balance Due	\$10.00

PRYOR AREA
CHAMBER OF COMMERCE, INC.

P.O. BOX 367
PRYOR, OK 74362

BUILDING A BETTER COMMUNITY TODAY - FOR TOMMORROW

RCB BANK

P.O. Box 8 Pryor, OK 74362
(918)825-4321 Member FDIC

018818

PAY **** THREE HUNDRED SIXTY & 0/100 DOLLARS

TO THE
ORDER OF:

DATE

AMOUNT

01/05/22

\$

**360.00

Green Country Tourism
2512 E 71st Street Ste G
Tulsa, OK 74136-5533

VOID AFTER 90 DAYS

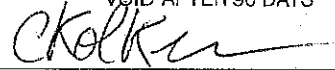

AUTHORIZED SIGNATURE



⑈018818⑈ ⑆103112594⑆ 04000121004⑈

PRYOR AREA CHAMBER OF COMMERCE, INC.

018818

Vendor ID: GC TOURISM

Name: Green Country Tourism

Check Date: 01/05/22

Check Amount: 360.00

MEMO:

Invoice # 12/22/2021 Membership
Invoice #12/22/2021 Christmas Luncheon

PRYOR AREA CHAMBER OF COMMERCE, INC.

018818

Vendor ID: GC TOURISM

Name: Green Country Tourism

Check Date: 01/05/22

Check Amount: 360.00

MEMO:

Invoice # 12/22/2021 Membership
Invoice #12/22/2021 Christmas Luncheon



Green Country Tourism
 2512 E 71st Street, Ste. G
 Tulsa, OK 74136-5533

Invoice

Date	10/4/2021
Invoice #	12526

Bill To
Pryor Chamber of Commerce Barbara Hawkins PO Box 367 Pryor, OK 74362

acct # 125000

Item Code	Description	Amount
Full Pg GREEN COUNTRY Public...	Two full pages with 6 advertisers in Co-Op Less Advertisers costs	2,830.00 -1,050.00
<div data-bbox="532 1566 1086 1667" data-label="Text"> <p>Thank you for your participation. We appreciate you.</p> </div>		

Green Country Tourism
 2512 E. 71st Street, Ste. G
 Tulsa, OK 74136

ad ID#: 73-0031478

918-744-0588

Admin@GreenCountryOk.com

Total	\$1,780.00
Balance Due	\$1,780.00

PRYOR AREA
CHAMBER OF COMMERCE, INC.

P.O. BOX 367
PRYOR, OK 74362

BUILDING A BETTER COMMUNITY TODAY - FOR TOMMORROW

RCB BANK

P.O. Box 8 Pryor, OK 74362
(918)825-4321 Member FDIC

018849

AY **** ONE THOUSAND SEVEN HUNDRED EIGHTY & 0/100 DOLLARS

TO THE
ORDER OF:

DATE 03/15/22 AMOUNT \$ **1780.00

Green Country Tourism
2512 E 71st Street Ste G
Tulsa, OK 74136-5533

VOID AFTER 90 DAYS

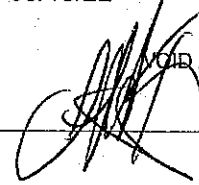

AUTHORIZED SIGNATURE



⑈018849⑈ ⑆103112594⑆ 04000121004⑈

PRYOR AREA CHAMBER OF COMMERCE, INC.

018849

Vendor ID: GC TOURISM

Name: Green Country Tourism
Check Date: 03/15/22
Check Amount: 1,780.00

MEMO:

Invoice #12526

PRYOR AREA CHAMBER OF COMMERCE, INC.

018849

Vendor ID: GC TOURISM

Name: Green Country Tourism
Check Date: 03/15/22
Check Amount: 1,780.00

MEMO:

Invoice #12526

baac
PRYOR AREA
CHAMBER OF COMMERCE

Pryor Area Chamber of Commerce
100 E. Graham Ave.
Pryor, OK 74361
918.825.0157
info@pryorchamber.com

HOTEL/MOTEL

Check #	Description	Amount
18780	Hotel Pryor (Rocklahoma Volunteer Accommodation)	\$ 358.62
18780	America's Best Value Inn (Rocklahoma Volunteer Accommodation)	\$ 79.26
	Hotel Pryor (Missoula Children's Theatre)	\$ 600.00
TOTAL		\$ 1,037.88

Transactions

Posting Date	Transaction Date	Description	Reference Number	Amount
10/08	10/07	PAYMENT - THANK YOU	2811530000000584503178	
TOTAL PAYMENTS AND OTHER CREDITS FOR THIS PERIOD				

10/18 10/18

HAWKINS, BARBARA
Account Number: 1774

Purchases and Other Charges				
09/20	09/17	HOTEL PRYOR PRYOR OK Arr: 09/17/21 Dep: 09/17/21 Inv: HO0004	55432861261200861658414	358.62
09/20	09/19	AMERICAS BEST VALUE IN PRYOR OK Arr: 09/19/21 Dep: 09/19/21 Inv: HO0005	55432861263200236587197	79.26

TOTAL PURCHASES AND OTHER CHARGES FOR THIS PERIOD

Finance Charge Calculation

Your Annual Percentage Rate (APR) is the annual interest rate on your account.

	Annual Percentage Rate	Balance Subject to Interest Rate	Finance Charges by Transaction Type
PURCHASES			
CASH		\$0.00	\$0.00

V = Variable Rate (rate may vary). Promotional Balance = APR for limited time on specified transactions.

Reward Summary

Beginning Balance		Other Bonuses
Earned		
Redeemed	.00	
Adjustments	.00	Ending Balance

To redeem your Cash Rewards call 1.800.673.1044, or visit www.bankofamerica.com

PRYOR AREA
CHAMBER OF COMMERCE, INC.

P.O. BOX 367
PRYOR, OK 74362

BUILDING A BETTER COMMUNITY TODAY - FOR TOMMORROW

018780

RCB BANK

P.O. Box 8 Pryor, OK 74362
(918)825-4321 Member FDIC

PAY **** NINE HUNDRED ELEVEN & 92/100 DOLLARS

TO THE
ORDER OF:

Business Card
PO Box 15796
Wilmington, DE 19886

DATE 11/04/21 AMOUNT \$ **911.92

VOID AFTER 90 DAYS

Cholke
AUTHORIZED SIGNATURE



⑈018780⑈ ⑆103112594⑆ 04000121004⑈

PRYOR AREA CHAMBER OF COMMERCE, INC.

018780

Vendor ID: BOFAMERICA

Name: Business Card
Check Date:
Check Amount:

11/04/21
911.92

MEMO:

Acct. # 5474976700308445

PRYOR AREA ARTS AND HUMANITIES COUNCIL

6 North Adair

Pryor, OK 74361

Pryor Area Chamber of Commerce
100 East Graham Avenue
Pryor, OK 74361

Thank you for helping bring Missoula Children's Theatre to Pryor. The musical production of Johnny Appleseed was a success enjoyed by all.

Pryor Area Chamber of Commerce agreed to support this production by contributing \$600.00 to help pay the hotel accommodations for the two directors for the week. The directors, Theresa Ann Smith and Morgan Victoria Bruewer, stayed at Hotel Pryor checking in Sunday afternoon, June 5, 2022 and checking out Sunday morning, June 12, 2022. The total cost of the two rooms was \$1,464.96. An invoice is attached. Please send your check to

Pryor Area Arts and Humanities Council
6 North Adair
Pryor, OK 74361

Again, thank you for helping us bring children's theatre to Pryor.

Sincerely,

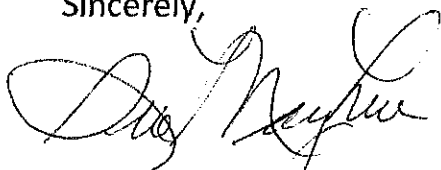

Sue C. Mayhue
Treasurer

Enc:

PRYOR AREA ARTS AND HUMANITIES COUNCIL

6 North Adair

Pryor, OK 74361

Invoice

Assistance with Hotel Accommodations for two Missoula Children's Theatre
Directors

\$600.00

MISSOULA CHILDREN'S THEATRE

A PRODUCTION OF MCT, INC.

Celebrating our 50th year of touring, the Missoula Children's Theatre International Tour has fostered developmental life skills in more than a million kids. Prior to Covid, we worked with 65,000 children in more than 1,100 communities in all 50 states and 17 countries each year. Our reach is increasing once again, but like all performing arts organizations, Covid-19 has had a devastating impact on our budget. One of the many ways the Missoula Children's Theatre remains vibrant is through generous donors all over the world. If you would like to help support MCT, **GIVE** online by visiting MCTinc.org or via **text** by texting "MCTGive" to 44321.

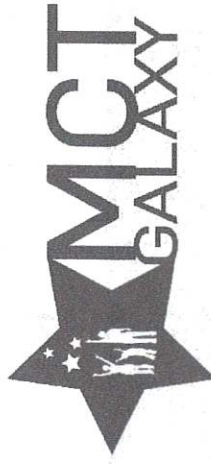

"Guess what? I made it...I'm in the play!"

On stage or behind the scenes, your children are STARS! We invite you to honor that experience with a "star" in the MCT Galaxy, located in MCT headquarters in Missoula, MT! To see a sample of the MCT Galaxy and learn more about this exciting way to celebrate your star and support MCT, search "galaxy" in the search bar on our website. Stars are only \$50 and can be customized with a name, the memory you wish to commemorate, date and location.

 [Missoula Children's Theatre](https://www.facebook.com/missoulatheatre)
 [@mctinc](https://twitter.com/mctinc)  [@missoulatheatre](https://www.instagram.com/missoulatheatre)

Missoula Children's Theatre
200 N. Adams, Missoula, MT 59802-4718
MCTinc.org 406-728-1911 tour@MCTinc.org



Written by
MICHAEL MCGILL
JIM CARON

Music and Lyrics by
MICHAEL MCGILL
JIM CARON
TOM TEN EYCK
DAVID SIMMONS

Copyright © 2019 MCT, Inc.
MISSOULA CHILDREN'S THEATRE (MCT, INC.)
200 North Adams Missoula, Montana 59802-4718
Phone 406-728-1911 Fax 406-721-0637
MCTinc.org

All Rights Reserved
Pryor Area Arts and Humanities Council says
thank you to Pryor Public Schools, to the Oklahoma Arts
Council and to Pryor Area Chamber of Commerce for
supporting this production.



Hotel Pryor

5401 S Mill Street , Pryor , Oklahoma, 74361, USA

Phone: 918-981-8900; Fax: 918-981-8901

E-mail: sleepmcalester@gmail.com

Name	Theresa Ann Smith		Folio No.	050622125254428	
Address	7832 HANCOCK ST NEW PORT RICHEY, FL, 346536234, USA				
Phone #	918 386 2624		Room	211 (NK)	
ID Type	Driver License	ID #	S5XXXXXXXXXX00	# of Guest	2
Issue Place	NEW PORT RICHEY	ID Country	USA	Date In	Jun/05/2022 02:56:00 PM
Vehicle Info.			Date Out	Jun/12/2022 11:00:00 AM	
Company					

Particulars		Total
Rental Charges	Rate Type: Best Available	595.00
Occupancy Tax		88.48
		683.48
Add : Other Charges		
Charges		49.00
		49.00
	Total Charges	732.48
Less : Payments		
Payment By Guest		732.48
		732.48
		0.00

NOTICE TO GUESTS: This property is privately owned and the management reserves the right to refuse service to anyone. Management will not be responsible for accidents or injury to guests or for loss of money, jewelry or valuables of any kind. Management will not be responsible for any item left in the room.

CHECKOUT TIME: 11:00 AM SELF REGISTRATION ONLY

I AGREE that my liability for this bill is not waived and agree to be held personally liable in the event that the indicated person or company failed to pay for any part or full amount of these charges including any missing/damaged items, etc.. I agree that if an attorney is retained to collect these charges, I will pay all reasonable attorney's fees and costs incurred. If payment is by credit card you are authorized to charge my account for all charges incurred, including any and all damages/missing items, etc.. I agree that the sole purpose of renting this room is for my own residency only.

Guest Signature _____
Date _____

Checked-In By Jenny
Checked-Out By
Printed By Jenny
Printed Date 6/11/2022 6:00 PM

Hotel Pryor

5401 S Mill Street , Pryor , Oklahoma, 74361, USA

Phone: 918-981-8900; Fax: 918-981-8901

E-mail: sleepmcalester@gmail.com

Name	Morgan Victoria Bruewer		Folio No.	050622125016849	
Address	1903 SE 12TH TER CAPE CORAL, FL, 33990-0000, USA				
Phone #	918 386 2624		Room	208 (NK)	
ID Type	Driver License	ID #	B6XXXXXXXXX70	# of Guest	2
Issue Place	CAPE CORAL	ID Country	USA	Date In	Jun/05/2022 02:52:00 PM
Vehicle Info.			Date Out	Jun/12/2022 11:00:00 AM	
Company					

Particulars		Total
Rental Charges	Rate Type: Best Available	595.00
Occupancy Tax		88.48
		683.48
Add : Other Charges		
Charges		49.00
		49.00
	Total Charges	732.48
Less : Payments		
Payment By Guest		732.48
		732.48
		0.00

NOTICE TO GUESTS: This property is privately owned and the management reserves the right to refuse service to anyone. Management will not be responsible for accidents or injury to guests or for loss of money, jewelry or valuables of any kind. Management will not be responsible for any item left in the room.

CHECKOUT TIME: 11:00 AM SELF REGISTRATION ONLY

I AGREE that my liability for this bill is not waived and agree to be held personally liable in the event that the indicated person or company failed to pay for any part or full amount of these charges including any missing/damaged items, etc.. I agree that if an attorney is retained to collect these charges, I will pay all reasonable attorney's fees and costs incurred. If payment is by credit card you are authorized to charge my account for all charges incurred, including any and all damages/missing items, etc.. I agree that the sole purpose of renting this room is for my own residency only.

Guest Signature _____
Date _____

Checked-In By Jenny
Checked-Out By
Printed By Jenny
Printed Date 6/11/2022 5:59 PM

baac
PRYOR AREA
CHAMBER OF COMMERCE

Pryor Area Chamber of Commerce
100 E. Graham Ave.
Pryor, OK 74361
918.825.0157
info@pryorchamber.com

JEFFERSON HIGHWAY

Check #	Description	Amount
18742	Jefferson Highway Proclamation Signing (Hotel Accommodation)	\$ 187.17
18851	Jefferson Highway Books	\$ 385.00
18897	Jefferson Highway Association Dues	\$ 255.00
	Jefferson Highway Hotel Expense—La Quinta Pittsburg, KS—OS Conference	\$ 406.08
	Jefferson Highway Hotel Expense—Caseys Pittsburg, KS—OS Conference	\$ 56.12
	Jefferson Highway Hotel Expense—La Quinta Pittsburg, KS—OS Conference (CREDIT)	\$ 127.38
TOTAL		\$ 1,416.75

Transactions

Posting Date	Transaction Date	Description	Reference Number	Amount
08/09	08/07	PAYMENT - THANK YOU		
		TOTAL PAYMENTS AND OTHER CREDITS FOR THIS PERIOD		

HAWKINS, BARBARA
Account Number: 1774

Purchases and Other Charges

08/06	08/04	STAYBRIDGE SUITES OKLAHOMA CITYOK <small>Arr: 08/03/21 Dep: 08/04/21 Inv: 1153921</small>	52704871217708558625449	187.17
-------	-------	--	-------------------------	--------

Finance Charge Calculation

Your Annual Percentage Rate (APR) is the annual interest rate on your account.

	Annual Percentage Rate	Balance Subject to Interest Rate	Finance Charges by Transaction Type
PURCHASES		\$0.00	\$0.00
CASH		\$0.00	\$0.00

V = Variable Rate (rate may vary). Promotional Balance = APR for limited time on specified transactions.

Reward Summary

Beginning Balance	
Earned	
Redeemed	.00
Adjustments	.00

To redeem your Cash Rewards call 1.800.673.1044. or visit www.bankofamerica.com

PRYOR AREA
CHAMBER OF COMMERCE, INC.

P.O. BOX 367
PRYOR, OK 74362

BUILDING A BETTER COMMUNITY TODAY - FOR TOMMORROW

RCB BANK

P.O. Box 8 Pryor, OK 74362
(918)825-4321 Member FDIC

018742

PAY **** NINE HUNDRED SEVENTY THREE & 39/100 DOLLARS

TO THE
ORDER OF:

DATE
09/10/21

AMOUNT
\$ **973.39

Business Card
PO Box 15796
Wilmington, DE 19886

VOID AFTER 90 DAYS

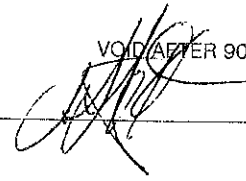

AUTHORIZED SIGNATURE



⑈018742⑈ ⑈103112594⑈ 04000121004⑈

PRYOR AREA CHAMBER OF COMMERCE, INC.

018742

Vendor ID: BOFAMERICA

Name: Business Card
Check Date:
Check Amount:

09/10/21
973.39

MEMO:

Acct. # 5474976700308445

PRYOR AREA CHAMBER OF COMMERCE, INC.

018742

Vendor ID: BOFAMERICA

Name: Business Card
Check Date:
Check Amount:

09/10/21
973.39

MEMO:

Acct. # 5474976700308445

**THE BIBLE BOOKSTORE
THE BOOK EXCHANGE**

**3 N. ADAIR ST.
PRYOR, OK 74361
(918) 825-6015**

CUSTOMER'S ORDER NO.		PHONE		DATE 3-29-22	
NAME Pryor Area					
ADDRESS Chamber of Commerce					
CASH	C.O.D.	CHARGE	ON ACCT.	MDSE. RET'D.	PAID OUT
		25 Jeff Hwy	15.40		385.00
SOLD BY					RECEIVED BY
					TOTAL 385.00

C PRODUCT 609 All claims and returned goods MUST be accompanied by this bill.

217158

Thank You

PRYOR AREA
CHAMBER OF COMMERCE, INC.

P.O. BOX 367
PRYOR, OK 74362

BUILDING A BETTER COMMUNITY TODAY - FOR TOMMORROW

RCB BANK

P.O. Box 8 Pryor, OK 74362
(918)825-4321 Member FDIC

018851

AY **** THREE HUNDRED EIGHTY FIVE & 0/100 DOLLARS

TO THE
ORDER OF:

The Book Exchange
3 North Adair Street
Pryor, OK 74361

DATE 03/29/22 AMOUNT \$ **385.00

VOID AFTER 90 DAYS

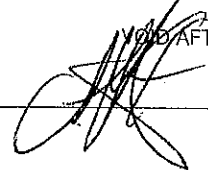

AUTHORIZED SIGNATURE



⑈018851⑈ ⑆103112594⑆ 04000121004⑈

PRYOR AREA CHAMBER OF COMMERCE, INC.

018851

Vendor ID: BOOK

Name: The Book Exchange
Check Date: 03/29/22
Check Amount: 385.00

MEMO:

Jefferson Highway Books

PRYOR AREA CHAMBER OF COMMERCE, INC.

018851

Vendor ID: BOOK

Name: The Book Exchange
Check Date: 03/29/22
Check Amount: 385.00

MEMO:

Jefferson Highway Books

Posting Date	Transaction Date	Description	Reference Number	Amount
05/02	05/02	PAYMENT - THANK YOU	1221530000000591148440	
TOTAL PAYMENTS AND OTHER CREDITS FOR THIS PERIOD				

HAWKINS, BARBARA
Account Number: 1774

Purchases and Other Charges

04/26	04/25	JEFFERSON HIGHWAY ASSO 828-5531828 MO	85500392115900015702103	255.00
-------	-------	---------------------------------------	-------------------------	--------

TOTAL PURCHASES AND OTHER CHARGES FOR THIS PERIOD

Your Annual Percentage Rate (APR) is the annual interest rate on your account

	Annual Percentage Rate	Balance Subject to Interest Rate	Finance Charges by Transaction Type
PURCHASES		\$0.00	\$0.00
CASH	/	\$0.00	\$0.00

V = Variable Rate (rate may vary) Promotional Balance = APR for limited time on specified transactions

Beginning Balance		Other Bonuses
Earned		
Redeemed	.00	
Adjustments	.00	Ending Balance

To redeem your Cash Rewards call 1 800 673 1044, or visit www.bankofamerica.com

PRYOR AREA
CHAMBER OF COMMERCE, INC.
P.O. BOX 367
PRYOR, OK 74362

BUILDING A BETTER COMMUNITY TODAY - FOR TOMMORROW

RCB BANK
P.O. Box 8 Pryor, OK 74362
(918)825-4321 Member FDIC

018897

**** ONE THOUSAND THREE HUNDRED NINETY NINE & 55/100 DOLLARS

TO THE
ORDER OF:

DATE

AMOUNT

06/07/22

\$

**1399.55

VOID AFTER 90 DAYS

Business Card
PO Box 15796
Wilmington, DE 19886



AUTHORIZED SIGNATURE



⑈018897⑈ ⑆103112594⑆ 04000121004⑈

PRYOR AREA CHAMBER OF COMMERCE, INC.

018897

Vendor ID: BOFAMERICA

Name: Business Card

Check Date:

06/07/22

Check Amount:

1,399.55

MEMO:

Acct. # 5474976700308445

PRYOR AREA CHAMBER OF COMMERCE, INC.

018897

Vendor ID: BOFAMERICA

Name: Business Card

Check Date:

06/07/22

Check Amount:

1,399.55

MEMO:

Acct. # 5474976700308445

60

1038110005

Posting Date	Transaction Date	Description	Reference Number	Amount
06/13	06/12	PAYMENT - THANK YOU	16415300000000571332179	
TOTAL PAYMENTS AND OTHER CREDITS FOR THIS PERIOD				

HAWKINS, BARBARA
Account Number: 1774

Payments and Other Credits				
06/06	06/04	LA QUINTA INNS AND SUI PITTSBURG KS Arr: 06/02/22 Dep: 06/04/22 Inv: 006124	55432862157200007241278	- 126.78
06/17	06/17	RBT KUM&GO 3861 PRYOR EasySavings NY	05587452168000000152968	- 0.60
TOTAL PAYMENTS AND OTHER CREDITS FOR THIS PERIOD				- \$127.38
Purchases and Other Charges				

06/06	06/03	+ CASEYS #3924 PITTSBURG KS	05436842155300230152550	56.12
06/06	06/04	+ LA QUINTA INNS AND SUI PITTSBURG KS + Arr: 06/02/22 Dep: 06/04/22 Inv: 006124	55432862157200007241252	406.08

Your Annual Percentage Rate (APR) is the annual interest rate on your account

	Annual Percentage Rate	Balance Subject to Interest Rate	Finance Charges by Transaction Type
PURCHASES		\$0.00	\$0.00
CASH		\$0.00	\$0.00

V = Variable Rate (rate may vary) Promotional Balance = APR for limited time on specified transactions

Beginning Balance		Other Bonuses
Earned		
Redeemed	00	
Adjustments	00	Ending Balance

To redeem your Cash Rewards call 1 800 673 1044 or visit www.bankofamerica.com

PRYOR AREA
CHAMBER OF COMMERCE, INC.
P.O. BOX 367
PRYOR, OK 74362
BUILDING A BETTER COMMUNITY TODAY - FOR TOMMORROW

RCB BANK
P.O. Box 8 Pryor, OK 74362
(918)825-4321 Member FDIC

018910

PAY **** ONE THOUSAND THREE HUNDRED EIGHTY FIVE & 67/100 DOLLARS

TO THE
ORDER OF:

DATE
07/05/22

AMOUNT

\$ **1385.67

VOID AFTER 90 DAYS

Business Card
PO Box 15796
Wilmington, DE 19886

AUTHORIZED SIGNATURE



⑈018910⑈ ⑆103112594⑆ 04000121004⑈

PRYOR AREA CHAMBER OF COMMERCE, INC.

018910

Vendor ID: BOFAMERICA

Name: Business Card
Check Date:
Check Amount:

07/05/22
1,385.67

MEMO:

Acct. # 5474976700308445

PRYOR AREA CHAMBER OF COMMERCE, INC.

018910

Vendor ID: BOFAMERICA

Name: Business Card
Check Date:
Check Amount:

07/05/22
1,385.67

MEMO:

Acct. # 5474976700308445

bacc
PRYOR AREA
CHAMBER OF COMMERCE

Pryor Area Chamber of Commerce
100 E. Graham Ave.
Pryor, OK 74361
918.825.0157
info@pryorchamber.com

LEAF - COPIER/SCANNER

Check #	Amount
CREDIT	\$ 169.55
18715	\$ 162.49
18735	\$ 306.45
18755	\$ 318.73
Online Payment	\$ 753.50
18788	\$ 96.83
ACH (Dec. 2021)	\$ 301.75
ACH (Jan. 2022)	\$ 365.69
ACH (Feb. 2022)	\$ 394.95
ACH (March 2022)	\$ 363.53
ACH (Apr. 2022)	\$ 401.17
ACH (May 2022)	\$ 384.49
ACH (June 2022)	\$ 349.71
TOTAL	\$ 4,368.84

LEAF
P.O. BOX 5066
HARTFORD, CT 06102-5066

866-219-7924

Address Service Requested

Please provide address/contact changes on the reverse side.

Remittance Section

Contract Number: 100-4111989-001
Invoice Number: 11959195
Invoice Due Date: 07/01/2021
Current Invoice Due:
Total Amount Due: \$160.55
Amount Remitted: \$

Payments received after 06/06/2021 are not reflected on this invoice.

Use enclosed envelope and make payable to:

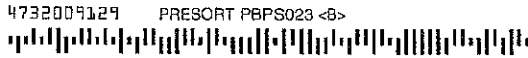

PRYOR AREA CHAMBER OF COMMERCE
PO BOX 367
PRYOR OK 74362-0367

LEAF
P.O. BOX 5066
HARTFORD, CT 06102-5066

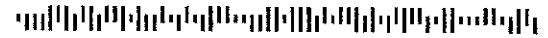

no action needed - June credit.

011004111989001000094695300119591950000169558

Keep lower portion for your records - Please return upper portion with your payment

LEAF
P.O. BOX 5066
HARTFORD, CT 06102-5066

Account Name: Pryor Area Chamber Of Commerce
Invoice Date: 06/06/2021
Invoice Due Date: 07/01/2021
Contract Number: 100-4111989-001
Invoice Number: 11959195
Total Due: \$160.55

Important Messages account # 15500

MyLEAFNow Gives You More Time for What Matters Most

Focus less on bills and more on business in today's demanding business environment with MyLEAFNow, an easier way to make sure invoices are paid on time, every time. With MyLEAFNow, everything you need to take control of your equipment financing is available right at your fingertips, wherever you work, on any connected device. Log in today at www.MyLEAFNow.com.

CONTRACT NUMBER	DESCRIPTION	CONTRACT PAYMENT	SALES/USE TAX	LATE CHARGES	TOTAL
100-4111989-001	Xerox C8045HX Copier System DATE DUE 07/01/21	\$59.90	\$21.20		\$81.10
	COLOR DATE DUE 07/01/21	\$65.05	\$6.42		\$71.47
	INSURANCE DATE DUE 07/01/21	\$16.98			\$16.98

PLEASE PAY THIS AMOUNT

160.55

Usage Report

Usage Profile Name	Meter Type	Reference # / Contract #	Previous Date	Current Date	Usage Credits	USAGE
Asset#	Make / Model / Serial	Location	Previous Meter	Current Meter		
Color	Color Xerox	100-4111989-001	2021-05-01	2021-06-01	0	1048

If you have questions regarding your bill, or if you would like to pay by phone please give us a call and we will be happy to assist you.

866-219-7924

(2)



Usage Report *continued*

Usage Profile Name	Meter Type Make / Model / Serial	Reference # / Contract # Location	Previous Date Previous Meter	Current Date Current Meter	Usage Credits	USAGE	
Color (Continued)	C8045 8TB555565	Office 100 East Graham Ave PRYOR OK 74361	27815	28863		1048	
			ALLOWANCE	EXCESS USAGE		RATE	CHARGE
			350	698		0.093200	\$65.05
Mono	B&W Xerox C8045 8TB555565	100-4111989-001 Office 100 East Graham Ave PRYOR OK 74361	2021-05-01 69546	2021-06-01 69972	0	426	
			ALLOWANCE	EXCESS USAGE		RATE	CHARGE
			1000	0		0.013300	\$0.00

Remittance Section

Contract Number: 100-4111989-001
 Invoice Number: 12069530
 Invoice Due Date: 08/01/2021
 Current Invoice Due:
 Total Amount Due: \$162.49
 Amount Remitted: \$ _____

Payments received after 07/07/2021 are not reflected on this invoice.

Use enclosed envelope and make payable to:

LEAF
 P.O. BOX 5066
 HARTFORD, CT 06102-5066



LEAF
 P.O. BOX 5066
 HARTFORD, CT 06102-5066

866-219-7924

Address Service Requested

Please provide address/contact changes on the reverse side.

4478006662 PRESORT PBPS017

 PRYOR AREA CHAMBER OF COMMERCE
 PO BOX 367
 PRYOR OK 74362-0367

011004111989001000094695300120695300000162498

Keep lower portion for your records - Please return upper portion with your payment

LEAF	Account Name: Pryor Area Chamber Of Commerce	Contract Number: 100-4111989-001
P.O. BOX 5066	Invoice Date: 07/07/2021	Invoice Number: 12069530
HARTFORD, CT 06102-5066	Invoice Due Date: 08/01/2021	Total Due: \$162.49

Important Messages

MyLEAFNow Gives You More Time for What Matters Most

Focus less on bills and more on business in today's demanding business environment with MyLEAFNow, an easier way to make sure invoices are paid on time, every time. With MyLEAFNow, everything you need to take control of your equipment financing is available right at your fingertips, wherever you work, on any connected device. Log in today at www.MyLEAFNow.com.

CONTRACT NUMBER	DESCRIPTION	CONTRACT PAYMENT	SALES/USE TAX	LATE CHARGES	TOTAL
100-4111989-001	Xerox C8045HX Copier System				
	DATE DUE 08/01/21	\$59.90	\$21.20		\$81.10
	COLOR				
	DATE DUE 08/01/21	\$58.62	\$5.79		\$64.41
	INSURANCE				
	DATE DUE 08/01/21	\$16.98			\$16.98
PLEASE PAY THIS AMOUNT					\$162.49

Usage Report

Usage Profile Name	Meter Type	Reference # / Contract #	Previous Date	Current Date	Usage Credits	USAGE
Asset#	Make / Model / Serial	Location	Previous Meter	Current Meter		
Color	Color Xerox	100-4111989-001	2021-06-01	2021-07-01	0	979

If you have questions regarding your bill, or if you would like to pay by phone please give us a call and we will be happy to assist you.

866-219-7924

LEAF
P.O. BOX 5066
HARTFORD, CT 06102-5066

Account Name:
Invoice Date:
Invoice Due Date:

Pryor Area Chamber Of Commerce
07/07/2021
08/01/2021

Contract Number:
Invoice Number:
Total Due:

100-4111989-001
12069530
\$162.49

FILE

Usage Report *continued*

Usage Profile Name Asset#	Meter Type Make / Model / Serial	Reference # / Contract # Location	Previous Date Previous Meter	Current Date Current Meter	Usage Credits	USAGE	
Color (Continued)	C8045 8TB555565	Office 100 East Graham Ave PRYOR OK 74361	28863	29842		979	
			ALLOWANCE	EXCESS USAGE		RATE	CHARGE
			350	629		0.093200	\$58.62
Mono	B&W Xerox C8045 8TB555565	100-4111989-001 Office 100 East Graham Ave PRYOR OK 74361	2021-06-01 69972	2021-07-01 70219	0	247	
			ALLOWANCE	EXCESS USAGE		RATE	CHARGE
			1000	0		0.013300	\$0.00

PRYOR AREA
CHAMBER OF COMMERCE, INC.

P.O. BOX 367
PRYOR, OK 74362

BUILDING A BETTER COMMUNITY TODAY - FOR TOMMORROW

RCB BANK

P.O. Box 8 Pryor, OK 74362
(918)825-4321 Member FDIC

018715

PAY **** ONE HUNDRED SIXTY TWO & 49/100 DOLLARS

TO THE
ORDER OF:

DATE

AMOUNT

07/21/21

\$

**162.49

LEAF
PO Box 5066
Hartford, CT, 06102

VOID AFTER 90 DAYS

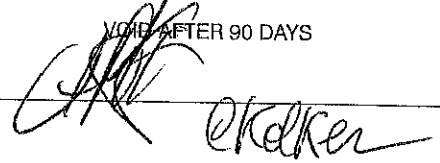

AUTHORIZED SIGNATURE



⑈018715⑈ ⑆103112594⑆ 04000121004⑈

PRYOR AREA CHAMBER OF COMMERCE, INC.

018715

Vendor ID: LEAF

Name: LEAF
Check Date:
Check Amount:

07/21/21
162.49

MEMO:

Inv no. 12069530

PRYOR AREA CHAMBER OF COMMERCE, INC.

018715

Vendor ID: LEAF

Name: LEAF
Check Date:
Check Amount:

07/21/21
162.49

MEMO:

Inv no. 12069530

LEAF
 P.O. BOX 5066
 HARTFORD, CT 06102-5066

866-219-7924

Address Service Requested



Please provide address/contact changes on the reverse side.

Remittance Section

Contract Number: 100-4111989-001
 Invoice Number: 12180939
 Invoice Due Date: 09/01/2021
 Current Invoice Due:
 Total Amount Due:
 Amount Remitted: \$ 306.45

Payments received after 08/07/2021 are not reflected on this invoice.

Use enclosed envelope and make payable to:

1654009965 PRESORT PBPS025

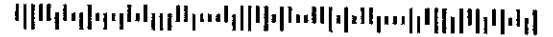
 PRYOR AREA CHAMBER OF COMMERCE
 PO BOX 367
 PRYOR OK 74362-0367

LEAF
 P.O. BOX 5066
 HARTFORD, CT 06102-5066

011004111989001000094695300121809390000306457

Keep lower portion for your records - Please return upper portion with your payment

LEAF
 P.O. BOX 5066
 HARTFORD, CT 06102-5066

Account Name: Pryor Area Chamber Of Commerce Contract Number: 100-4111989-001
 Invoice Date: 08/07/2021 Invoice Number: 12180939
 Invoice Due Date: 09/01/2021 Total Due: \$306.45

Important Messages

MyLEAFNow Gives You More Time for What Matters Most

Focus less on bills and more on business in today's demanding business environment with MyLEAFNow, an easier way to make sure invoices are paid on time, every time. With MyLEAFNow, everything you need to take control of your equipment financing is available right at your fingertips, wherever you work, on any connected device. Log in today at www.MyLEAFNow.com.

acct. # 15500

IDENTIFICATION NUMBER	DESCRIPTION	PAYMENT	SALES/USE TAX	LATE CHARGES	TOTAL
Contract Number 100-4111989-001	Xerox C8045HX Copier System DATE DUE 09/01/21 COLOR	\$166.27	\$21.20		\$187.47
	DATE DUE 09/01/21 INSURANCE	\$92.83	\$9.17		\$102.00
	DATE DUE 09/01/21	\$16.98			\$16.98
PLEASE PAY THIS AMOUNT					\$306.45

Usage Report

Usage Profile Name	Meter Type Make / Model / Serial	Reference # / Contract # Location	Previous Date Previous Meter	Current Date Current Meter	Usage Credits	USAGE
Color	Color					

If you have questions regarding your bill, or if you would like to pay by phone please give us a call and we will be happy to assist you.

866-219-7924

LEAF
P.O. BOX 5066
HARTFORD, CT 06102-5066

Account Name:
Invoice Date:
Invoice Due Date:

Pryor Area Chamber Of Commerce
08/07/2021
09/01/2021

Contract Number:
Invoice Number:
Total Due:

100-4111989-001
12180939
\$306.83



Usage Report *continued*

Usage Profile Name	Meter Type Make / Model / Serial	Reference # / Contract # Location	Previous Date Previous Meter	Current Date Current Meter	Usage Credits	USAGE	
Color (Continued)	Xerox C8045 8TB555565	100-4111989-001 Office 100 East Graham Ave PRYOR OK 74361	2021-07-01 29842	2021-08-01 31188	0	1346	
						1346	
			ALLOWANCE	EXCESS USAGE		RATE	CHARGE
			350	996		0.093200	\$92.83
Mono	B&W Xerox C8045 8TB555565	100-4111989-001 Office 100 East Graham Ave PRYOR OK 74361	2021-07-01 70219	2021-08-01 70980	0	761	
						761	
			ALLOWANCE	EXCESS USAGE		RATE	CHARGE
			1000	0		0.013300	\$0.00

PRYOR AREA
CHAMBER OF COMMERCE, INC.

P.O. BOX 367
PRYOR, OK 74362

BUILDING A BETTER COMMUNITY TODAY - FOR TOMMORROW

RCB BANK

P.O. Box 8 Pryor, OK 74362
(918)825-4321 Member FDIC

018735

**** THREE HUNDRED SIX & 45/100 DOLLARS

TO THE
ORDER OF:

DATE
08/24/21

AMOUNT
\$ **306.45

LEAF
PO Box 5066
Hartford, CT, 06102

VOID AFTER 90 DAYS

AUTHORIZED SIGNATURE



⑈018735⑈ ⑆103112594⑆ 04000121004⑈

PRYOR AREA CHAMBER OF COMMERCE, INC.

018735

Vendor ID: LEAF

Name: LEAF

Check Date:

08/24/21

Check Amount:

306.45

MEMO:

Invoice #12180939

PRYOR AREA CHAMBER OF COMMERCE, INC.

018735

Vendor ID: LEAF

Name: LEAF

Check Date:

08/24/21

Check Amount:

306.45

MEMO:

Invoice #12180939

LEAF
P.O. BOX 5066
HARTFORD, CT 06102-5066
866-219-7924

Address Service Requested



Please provide address/contact changes on the reverse side.

Remittance Section

Contract Number: 100-4111989-001
Invoice Number: 12288518
Invoice Due Date: 10/01/2021
Current Invoice Due:
Total Amount Due: \$318.73
Amount Remitted: \$ _____

Payments received after 09/06/2021 are not reflected on this invoice.

Use enclosed envelope and make payable to:

9816009760 PRESORT PBPS025

 PRYOR AREA CHAMBER OF COMMERCE
PO BOX 367
PRYOR OK 74362-0367

LEAF
P.O. BOX 5066
HARTFORD, CT 06102-5066



011004111989001000094695300122885180000318733

Keep lower portion for your records - Please return upper portion with your payment

LEAF
P.O. BOX 5066
HARTFORD, CT 06102-5066

Account Name: Pryor Area Chamber Of Commerce Contract Number: 100-4111989-001
Invoice Date: 09/06/2021 Invoice Number: 12288518
Invoice Due Date: 10/01/2021 Total Due: \$318.73

Important Messages

MyLEAFNow Gives You More Time for What Matters Most

Focus less on bills and more on business in today's demanding business environment with MyLEAFNow, an easier way to make sure invoices are paid on time, every time. With MyLEAFNow, everything you need to take control of your equipment financing is available right at your fingertips, wherever you work, on any connected device. Log in today at www.MyLEAFNow.com.

Acct. # 15500

IDENTIFICATION NUMBER	DESCRIPTION	PAYMENT	SALES/USE TAX	LATE CHARGES	TOTAL
Contract Number 100-4111989-001	Xerox C8045HX Copier System DATE DUE 10/01/21	\$280.55	\$21.20		\$301.75
	INSURANCE DATE DUE 10/01/21	\$16.98			\$16.98
PLEASE PAY THIS AMOUNT					\$318.73

Usage Report

Usage Profile Name	Meter Type Make / Model / Serial	Reference # / Contract # Location	Previous Date Previous Meter	Current Date Current Meter	Usage Credits	USAGE
Color	Color Xerox C8045	100-4111989-001 Office	2021-08-01 31188	2021-09-01 31520	0	332

If you have questions regarding your bill, or if you would like to pay by phone please give us a call and we will be happy to assist you. 866-219-7924

LEAF
P.O. BOX 5066
HARTFORD, CT 06102-5066

Account Name:
Invoice Date:
Invoice Due Date:

City Area Chamber of Commerce
09/06/2021
10/01/2021

Contract Number:
Invoice Number:
Total Due:

100-411989-001
12288518
\$318.73



Usage Report *continued*

Usage Profile Name Asset#	Meter Type Make / Model / Serial	Reference # / Contract # Location	Previous Date Previous Meter	Current Date Current Meter	Usage Credits	USAGE	
Color (Continued)	8TB555565	100 East Graham Ave PRYOR OK 74361				332	
			ALLOWANCE	EXCESS USAGE		RATE	CHARGE
			350	0		0.093200	\$0.00
Mono	B&W Xerox C8045 6TB555565	100-411989-001 Office 100 East Graham Ave PRYOR OK 74361	2021-08-01 70980	2021-09-01 71107	0	127	
			ALLOWANCE	EXCESS USAGE		RATE	CHARGE
			1000	0		0.013300	\$0.00

018755

PRYOR AREA

MEMBER OF COMMERCE, INC.

P.O. BOX 367

PRYOR, OK 74362

BUILDING A BETTER COMMUNITY TODAY - FOR TOMMORROW

RCB NK

P.O. Box 8 Pryor, OK 74362
(918)825-4321 Member FDIC

**** THREE HUNDRED EIGHTEEN & 73/100 DOLLARS

PAY

TO THE
ORDER OF:

LEAF
PO Box 5066
Hartford, CT, 06102

DATE AMOUNT
09/16/21 \$ **318.73

VOID AFTER 90 DAYS

[Handwritten Signature]

AUTHORIZED SIGNATURE



⑈018755⑈ ⑆0312594⑆ 04000121004⑈

PRYOR AREA CHAMBER OF COMMERCE, INC.

018755

Vendor ID: LEAF

Name: LEAF

Check Date: 09/16/21

Check Amount: 318.73

MEMO:

Invoice #12288518

LEAF
P.O. BOX 5066
HARTFORD, CT 06102-5066

866-219-7924

Address Service Requested

Please provide address/contact changes on the reverse side.

Remittance Section

Contract Number: 100-4111989-001
Invoice Number: 12402067
Invoice Due Date: 11/01/2021
Current Invoice Due:
Total Amount Due: \$753.50
Amount Remitted: \$ 753.50

Payments received after 10/07/2021 are not reflected on this invoice.

Use enclosed envelope and make payable to:

LEAF
P.O. BOX 5066
HARTFORD, CT 06102-5066

1840006749 PRESORT PBPS017
PRYOR AREA CHAMBER OF COMMERCE
PO BOX 367
PRYOR OK 74362-0367

011004111989001000094695300124020670000753506

Keep lower portion for your records - Please return upper portion with your payment

LEAF Account Name: Pryor Area Chamber Of Commerce Contract Number: 100-4111989-001
P.O. BOX 5066 Invoice Date: 10/07/2021 Invoice Number: 12402067
HARTFORD, CT 06102-5066 Invoice Due Date: 11/01/2021 Total Due: \$753.50

Important Messages

MyLEAFNow Gives You More Time for What Matters Most

Focus less on bills and more on business in today's demanding business environment with MyLEAFNow, an easier way to make sure invoices are paid on time, every time. With MyLEAFNow, everything you need to take control of your equipment financing is available right at your fingertips, wherever you work, on any connected device. Log in today at www.MyLEAFNow.com.

IDENTIFICATION NUMBER	DESCRIPTION	PAYMENT	SALES/USE TAX	LATE CHARGES	TOTAL
Contract Number 100-4111989-001	Xerox C8045HX Copier System DATE DUE 11/01/21 COLOR	\$280.55	\$21.20		\$301.75
	DATE DUE 11/01/21 B&W	\$358.14	\$35.37		\$393.51
	DATE DUE 11/01/21 INSURANCE	\$37.55	\$3.71		\$41.26
	DATE DUE 11/01/21	\$16.98			\$16.98
PLEASE PAY THIS AMOUNT					\$753.50

account # 15500

If you have questions regarding your bill, or if you would like to pay by phone please give us a call and we will be happy to assist you.

866-219-7924

LEAF
P.O. BOX 5066
HARTFORD, CT 06102-5066

Account Name:
Invoice Date:
Invoice Due Date:

Pryor Area Chamber Of Commerce
10/07/2021
11/01/2021

Contract Number:
Invoice Number:
Total Due:

100-4111989-001
12402067
\$753.50



Usage Report

Usage Profile Name	Meter Type Make / Model / Serial	Reference # / Contract # Location	Previous Date Previous Meter	Current Date Current Meter	Usage Credits	USAGE	
Color (Continued)	Color Xerox C8045 8TB555565	100-4111989-001 Office 100 East Graham Ave PRYOR OK 74361	2021-09-01 31520	2021-10-01 35364	0	3844	
						3844	
			ALLOWANCE	EXCESS USAGE		RATE	CHARGE
			350	3494		0.102500	\$358.14
Mono	B&W Xerox C8045 8TB555565	100-4111989-001 Office 100 East Graham Ave PRYOR OK 74361	2021-09-01 71107	2021-10-01 74679	0	3572	
						3572	
			ALLOWANCE	EXCESS USAGE		RATE	CHARGE
			1000	2572		0.014600	\$37.55

LEAF
P.O. BOX 5066
HARTFORD, CT 06102-5066

866-219-7924

Address Service Requested

Please provide address/contact changes on the reverse side.

PRYOR AREA CHAMBER OF COMMERCE
PO BOX 367
PRYOR OK 74362-0367

Remittance Section

Contract Number: 100-4111989-001
Invoice Number: 12514601
Invoice Due Date: 12/01/2021
Current Invoice Due:
Total Amount Due: \$96.83
Amount Remitted: \$ _____

Payments received after 11/06/2021 are not reflected on this invoice.

Use enclosed envelope and make payable to:

LEAF
P.O. BOX 5066
HARTFORD, CT 06102-5066



011004111989001000094695300125146010000096832

Keep lower portion for your records - Please return upper portion with your payment

LEAF
P.O. BOX 5066
HARTFORD, CT 06102-5066

Account Name: Pryor Area Chamber Of Commerce Contract Number: 100-4111989-001
Invoice Date: 11/06/2021 Invoice Number: 12514601
Invoice Due Date: 12/01/2021 Total Due: \$96.83

Important Messages

MyLEAFNow Gives You More Time for What Matters Most

Focus less on bills and more on business in today's demanding business environment with MyLEAFNow, an easier way to make sure invoices are paid on time, every time. With MyLEAFNow, everything you need to take control of your equipment financing is available right at your fingertips, wherever you work, on any connected device. Log in today at www.MyLEAFNow.com.

IDENTIFICATION NUMBER	DESCRIPTION	PAYMENT	SALES/USE TAX	LATE CHARGES	TOTAL
Contract Number 100-4111989-001	Xerox C8045HX Copier System COLOR				
	DATE DUE 12/01/21	\$72.67	\$7.18		\$79.85
	INSURANCE DATE DUE 12/01/21	\$16.98			\$16.98
PLEASE PAY THIS AMOUNT					\$96.83

Usage Report

Usage Profile Name Asset#	Meter Type Make / Model / Serial	Reference # / Contract # Location	Previous Date Previous Meter	Current Date Current Meter	Usage Credits	USAGE
Color	Color Xerox	100-4111989-001	2021-10-01	2021-11-01	0	1059

If you have questions regarding your bill, or if you would like to pay by phone please give us a call and we will be happy to assist you.

866-219-7924

LEAF
P.O. BOX 5066
HARTFORD, CT 06102-5066

ACCOUNT NAME:
Invoice Date:
Invoice Due Date:

Plyor Area Chamber Of Commerce Contract Number:
11/06/2021 Invoice Number:
12/01/2021 Total Due:

100-4111989-001
12514601
\$96.83

Usage Report *continued*

Usage Profile Name Asset#	Meter Type Make / Model / Serial	Reference # / Contract # Location	Previous Date Previous Meter	Current Date Current Meter	Usage Credits	USAGE
Color (Continued)	C8045 8TB555565	Office 100 East Graham Ave PRYOR OK 74361	35364	36423		1059
			ALLOWANCE	EXCESS USAGE		RATE CHARGE
			350	709		0.102500 \$72.67
Mono	B&W Xerox C8045 8TB555565	100-4111989-001 Office 100 East Graham Ave PRYOR OK 74361	2021-10-01 74679	2021-11-01 75208	0	529
			ALLOWANCE	EXCESS USAGE		RATE CHARGE
			1000	0		0.014600 \$0.00

PRYOR AREA
CHAMBER OF COMMERCE, INC.

P.O. BOX 367
PRYOR, OK 74362

BUILDING A BETTER COMMUNITY TODAY - FOR TOMMORROW

RCB BANK

P.O. Box 8 Pryor, OK 74362
(918)825-4321 Member FDIC

018788

PAY **** NINETY SIX & 83/100 DOLLARS

TO THE
ORDER OF:

DATE
11/22/21

AMOUNT
\$ **96.83

LEAF
PO Box 5066
Hartford, CT, 06102

VOID AFTER 90 DAYS

[Handwritten Signature]

AUTHORIZED SIGNATURE



⑈018788⑈ ⑆103112594⑆ 04000121004⑈

PRYOR AREA CHAMBER OF COMMERCE, INC.

018788

Vendor ID: LEAF

Name: LEAF

Check Date:

11/22/21

Check Amount:

96.83

MEMO:

Invoice Number 12514601

PRYOR AREA CHAMBER OF COMMERCE, INC.

018788

Vendor ID: LEAF

Name: LEAF

Check Date:

11/22/21

Check Amount:

96.83

MEMO:

Invoice Number 12514601

100-4111989-001 Pryor Area Chamber of Commerce

Payment Rcvd	Date Rcvd	Amount Rcvd	Invoice
ACH	12/1/2021	\$ 301.75	12523077

acct. # 15500

LEAF
P.O. BOX 5066
HARTFORD, CT 06102-5066

866-219-7924

Address Service Requested



Please provide address/contact changes on the reverse side.

Remittance Section

Contract Number: 100-4111989-001
Invoice Number: 12627567
Invoice Due Date: 01/01/2022
Current Invoice Due:
Total Amount Due: \$365.69
Amount Remitted: \$

Payments received after 12/07/2021 are not reflected on this invoice.

Use enclosed envelope and make payable to:

8736006915 PRESORT PBPS018

 PRYOR AREA CHAMBER OF COMMERCE
PO BOX 367
PRYOR OK 74362-0367

LEAF
P.O. BOX 5066
HARTFORD, CT 06102-5066



011004111989001000094695300126275670000365695

Keep lower portion for your records - Please return upper portion with your payment

LEAF
P.O. BOX 5066
HARTFORD, CT 06102-5066

Account Name: Pryor Area Chamber Of Commerce Contract Number: 100-4111989-001
Invoice Date: 12/07/2021 Invoice Number: 12627567
Invoice Due Date: 01/01/2022 Total Due: \$365.69

Important Messages

MyLEAFNow Gives You More Time for What Matters Most

Focus less on bills and more on business in today's demanding business environment with MyLEAFNow, an easier way to make sure invoices are paid on time, every time. With MyLEAFNow, everything you need to take control of your equipment financing is available right at your fingertips, wherever you work, on any connected device. Log in today at www.MyLEAFNow.com.

acct. # 15500

IDENTIFICATION NUMBER	DESCRIPTION	PAYMENT	SALES/USE TAX	LATE CHARGES	TOTAL
Contract Number 100-4111989-001	Xerox C8045HX Copier System P.O.NUM: ACH-DO NOT PAY DATE DUE 01/01/22 COLOR	\$280.55	\$21.20		\$301.75
	DATE DUE 01/01/22 INSURANCE	\$42.74	\$4.22		\$46.96
	DATE DUE 01/01/22	\$16.98			\$16.98
PLEASE PAY THIS AMOUNT					\$365.69

LLPA
P.O. BOX 5066
HARTFORD, CT 06102-5066

Account Name:
Invoice Date:
Invoice Due Date:

Pryor Area Chapter of Commerce
12/07/2021
01/01/2022

Contract Number:
Invoice Number:
Total Due:

100-4111989-001
12627567
\$365.69



Usage Report

Usage Profile Name	Meter Type Make / Model / Serial	Reference # / Contract # Location	Previous Date Previous Meter	Current Date Current Meter	Usage Credits	USAGE	
Color (Continued)	Color Xerox C8045 8TB555565	100-4111989-001 Office 100 East Graham Ave PRYOR OK 74361	2021-11-01 36423	2021-12-01 37190	0	767	
						767	
			ALLOWANCE	EXCESS USAGE		RATE	CHARGE
			350	417		0.102500	\$42.74
Mono	B&W Xerox C8045 8TB555565	100-4111989-001 Office 100 East Graham Ave PRYOR OK 74361	2021-11-01 75208	2021-12-01 75543	0	335	
						335	
			ALLOWANCE	EXCESS USAGE		RATE	CHARGE
			1000	0		0.014600	\$0.00

LEAF
P.O. BOX 5066
HARTFORD, CT 06102-5066

866-219-7924

Address Service Requested

Please provide address/contact changes on the reverse side.

2892006913 PRESORT PBPS018



PRYOR AREA CHAMBER OF COMMERCE
PO BOX 367
PRYOR OK 74362-0367

Remittance Section

Contract Number: 100-4111989-001
Invoice Number: 12742464
Invoice Due Date: 02/01/2022
Current Invoice Due:
Total Amount Due: \$394.95
Amount Remitted: \$ 394.95

Payments received after 01/07/2022 are not reflected on this invoice.

Use enclosed envelope and make payable to:

ACH

LEAF
P.O. BOX 5066
HARTFORD, CT 06102-5066



011004111989001000094695300127424640000394954

Keep lower portion for your records - Please return upper portion with your payment

LEAF
P.O. BOX 5066
HARTFORD, CT 06102-5066

Account Name: Pryor Area Chamber Of Commerce Contract Number: 100-4111989-001
Invoice Date: 01/07/2022 Invoice Number: 12742464
Invoice Due Date: 02/01/2022 Total Due: \$394.95

Important Messages

MyLEAFNow Gives You More Time for What Matters Most

Focus less on bills and more on business in today's demanding business environment with MyLEAFNow, an easier way to make sure invoices are paid on time, every time. With MyLEAFNow, everything you need to take control of your equipment financing is available right at your fingertips, wherever you work, on any connected device. Log in today at www.MyLEAFNow.com.

account # 15500

IDENTIFICATION NUMBER	DESCRIPTION	PAYMENT	SALES/USE TAX	LATE CHARGES	TOTAL
Contract Number 100-4111989-001	Xerox C8045HX Copier System P.O.NUM: ACH-DO NOT PAY DATE DUE 02/01/22 COLOR	\$280.55	\$21.20		\$301.75
	DATE DUE 02/01/22 2021 PROPERTY TAX	\$18.04	\$1.78		\$19.82
	DATE DUE 02/01/22 INSURANCE	\$51.33	\$5.07		\$56.40
	DATE DUE 02/01/22	\$16.98			\$16.98
PLEASE PAY THIS AMOUNT					\$394.95

LEAF
P.O. BOX 5066
HARTFORD, CT 06102-5066

Account Name:
Invoice Date:
Invoice Due Date:

Pryor Area Chamber Of Commerce
01/07/2022
02/01/2022

Contract Number: 100-411989-001
Invoice Number: 12742464
Total Due: \$394.95



Usage Report

Usage Profile Name	Meter Type Make / Model / Serial	Reference # / Contract # Location	Previous Date Previous Meter	Current Date Current Meter	Usage Credits	USAGE	
Color (Continued)	Color Xerox C8045 8TB555565	100-411989-001 Office 100 East Graham Ave PRYOR OK 74361	2021-12-01 37190	2022-01-01 37716	0	526	
						526	
			ALLOWANCE	EXCESS USAGE		RATE	CHARGE
			350	176		0.102500	\$18.04
Mono	B&W Xerox C8045 8TB555565	100-411989-001 Office 100 East Graham Ave PRYOR OK 74361	2021-12-01 75543	2022-01-01 76209	0	666	
						666	
			ALLOWANCE	EXCESS USAGE		RATE	CHARGE
			1000	0		0.014600	\$0.00

LEAF
P.O. BOX 5066
HARTFORD, CT 06102-5066

866-219-7924

Address Service Requested

Please provide address/contact changes on the reverse side.

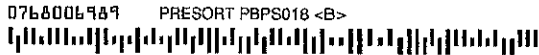

PRYOR AREA CHAMBER OF COMMERCE
PO BOX 367
PRYOR OK 74382-0367

Remittance Section

Contract Number: 100-4111989-001
Invoice Number: 12855057
Invoice Due Date: 03/01/2022
Current Invoice Due:
Total Amount Due: \$363.56
Amount Remitted: \$ 363.53

Payments received after 02/04/2022 are not reflected on this invoice.

Use enclosed envelope and make payable to:

ACH

LEAF
P.O. BOX 5066
HARTFORD, CT 06102-5066



011004111989001000094695300128550570000363562

Keep lower portion for your records - Please return upper portion with your payment

LEAF
P.O. BOX 5066
HARTFORD, CT 06102-5066

Account Name: Pryor Area Chamber Of Commerce Contract Number: 100-4111989-001
Invoice Date: 02/04/2022 Invoice Number: 12855057
Invoice Due Date: 03/01/2022 Total Due: \$363.56

Important Messages

MyLEAFNow Gives You More Time for What Matters Most

Focus less on bills and more on business in today's demanding business environment with MyLEAFNow, an easier way to make sure invoices are paid on time, every time. With MyLEAFNow, everything you need to take control of your equipment financing is available right at your fingertips, wherever you work, on any connected device. Log in today at www.MyLEAFNow.com.

acct. # 15500

IDENTIFICATION NUMBER	DESCRIPTION	PAYMENT	SALES/USE TAX	LATE CHARGES	TOTAL
Contract Number 100-4111989-001	Xerox C8045HX Copier System P.O.NUM: ACH-DO NOT PAY DATE DUE 03/01/22 COLOR	\$280.55	\$21.20		\$301.75
	DATE DUE 03/01/22 INSURANCE	\$40.80	\$4.03		\$44.83
	DATE DUE 03/01/22	\$16.98			\$16.98
PLEASE PAY THIS AMOUNT					\$363.56

If you have questions regarding your bill, or if you would like to pay by phone please give us a call and we will be happy to assist you.

866-219-7924



Usage Report

Usage Profile Name	Meter Type Make / Model / Serial	Reference # / Contract # Location	Previous Date Previous Meter	Current Date Current Meter	Usage Credits	USAGE		
Color (Continued)	Color Xerox C8045 8TB555565	100-4111989-001 Office 100 East Graham Ave PRYOR OK 74361	2022-01-01 37716	2022-02-01 38464	0	748		
							748	
			ALLOWANCE	EXCESS USAGE		RATE	CHARGE	
			350	398		0.102500	\$40.80	
Mono	B&W Xerox C8045 8TB555565	100-4111989-001 Office 100 East Graham Ave PRYOR OK 74361	2022-01-01 76209	2022-02-01 76610	0	401		
							401	
			ALLOWANCE	EXCESS USAGE		RATE	CHARGE	
			1000	0		0.014600	\$0.00	

LEAF
P.O. BOX 5066
HARTFORD, CT 06102-5066

866-219-7924

Address Service Requested



Please provide address/contact changes on the reverse side.

Remittance Section

Contract Number: 100-4111989-001
Invoice Number: 12972299
Invoice Due Date: 04/01/2022
Current Invoice Due:
Total Amount Due:
Amount Remitted: \$ 401.17

Payments received after 03/07/2022 are not reflected on this invoice.

Use enclosed envelope and make payable to:

3022008328 PRESORT PBPS021

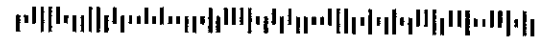
 PRYOR AREA CHAMBER OF COMMERCE
PO BOX 367
PRYOR OK 74362-0367

LEAF
P.O. BOX 5066
HARTFORD, CT 06102-5066

011004111989001000094695300129722990000401174

Keep lower portion for your records - Please return upper portion with your payment

LEAF
P.O. BOX 5066
HARTFORD, CT 06102-5066

Account Name: Pryor Area Chamber Of Commerce Contract Number: 100-4111989-001
Invoice Date: 03/07/2022 Invoice Number: 12972299
Invoice Due Date: 04/01/2022 Total Due: 501.17

Important Messages

MyLEAFNow Gives You More Time for What Matters Most

Focus less on bills and more on business in today's demanding business environment with MyLEAFNow, an easier way to make sure invoices are paid on time, every time. With MyLEAFNow, everything you need to take control of your equipment financing is available right at your fingertips, wherever you work, on any connected device. Log in today at www.MyLEAFNow.com.

IDENTIFICATION NUMBER	DESCRIPTION	PAYMENT	SALES/USE TAX	LATE CHARGES	TOTAL
Contract Number 100-4111989-001	Xerox C8045HX Copier System P.O.NUM: ACH-DO NOT PAY DATE DUE 04/01/22 COLOR	\$280.55	\$21.20		\$301.75
	DATE DUE 04/01/22 INSURANCE	\$75.03	\$7.41		\$82.44
	DATE DUE 04/01/22	\$16.98			\$16.98
TOTAL PAYABLE AMOUNT					\$399.17

acct. # 15500

If you have questions regarding your bill, or if you would like to pay by phone please give us a call and we will be happy to assist you.



Usage Report

Usage Profile Name	Meter Type Make / Model / Serial	Reference # / Contract # Location	Previous Date Previous Meter	Current Date Current Meter	Usage Credits	USAGE			
Color (Continued)	Color Xerox C8045 8TB555565	100-4111989-001 Office 100 East Graham Ave PRYOR OK 74361	2022-02-01 38464	2022-03-01 39546	0	1082			
						1082			
						ALLOWANCE	EXCESS USAGE	RATE	CHARGE
						350	732	0.102500	\$75.03
Mono	B&W Xerox C8045 8TB555565	100-4111989-001 Office 100 East Graham Ave PRYOR OK 74361	2022-02-01 76610	2022-03-01 77002	0	392			
						392			
						ALLOWANCE	EXCESS USAGE	RATE	CHARGE
						1000	0	0.014600	\$0.00

LEAF
P.O. BOX 5066
HARTFORD, CT 06102-5066

866-219-7924

Address Service Requested



Please provide address/contact changes on the reverse side.

Remittance Section

Contract Number: 100-4111989-001
Invoice Number: 13089585
Invoice Due Date: 05/01/2022
Current Invoice Due:
Total Amount Due:
Amount Remitted: \$ 384.49

Payments received after 04/06/2022 are not reflected on this invoice.

Use enclosed envelope and make payable to:

6668007028 PRESORT PBPS018

 PRYOR AREA CHAMBER OF COMMERCE
PO BOX 367
PRYOR OK 74362-0367

LEAF
P.O. BOX 5066
HARTFORD, CT 06102-5066



011004111989001000094695300130895850000384493

Keep lower portion for your records - Please return upper portion with your payment

LEAF
P.O. BOX 5066
HARTFORD, CT 06102-5066

Account Name: Pryor Area Chamber Of Commerce
Invoice Date: 04/06/2022 Invoice Number: 13089585
Invoice Due Date: 05/01/2022

Important Messages

MyLEAFNow Gives You More Time for What Matters Most

Focus less on bills and more on business in today's demanding business environment with MyLEAFNow, an easier way to make sure invoices are paid on time, every time. With MyLEAFNow, everything you need to take control of your equipment financing is available right at your fingertips, wherever you work, on any connected device. Log in today at www.MyLEAFNow.com.

acct # 15500

IDENTIFICATION NUMBER	DESCRIPTION	PAYMENT	SALES/USE TAX	LATE CHARGES	TOTAL
Contract Number 100-4111989-001	Xerox C8045HX Copier System P.O.NUM: ACH-DO NOT PAY DATE DUE 05/01/22 COLOR	\$280.55	\$21.20		\$301.75
	DATE DUE 05/01/22 INSURANCE	\$59.86	\$5.90		\$65.76
	DATE DUE 05/01/22	\$16.98			\$16.98

PLEASE PAY WITH CHECK

15500

If you have questions regarding your bill, or if you would like to pay by phone please give us a call and we will be happy to assist you.

LEAF
P.O. BOX 5066
HARTFORD, CT 06102-5066

Account Name:
Invoice Date:
Invoice Due Date:

Pryor Area Chamber Of Commerce
04/06/2022
05/01/2022

Contract Number:
Invoice Number:
Total Due:

100-4111989-001
13089585
13089585



Usage Report

Usage Profile Name Asset#	Meter Type Make / Model / Serial	Reference # / Contract # Location	Previous Date Previous Meter	Current Date Current Meter	Usage Credits	USAGE	
Color (Continued)	Color Xerox C8045 8TB555565	100-4111989-001 Office 100 East Graham Ave PRYOR OK 74361	2022-03-01 39546	2022-04-01 40480	0	934	
						934	
			ALLOWANCE	EXCESS USAGE		RATE	CHARGE
			350	584		0.102500	\$59.86
Mono	B&W Xerox C8045 8TB555565	100-4111989-001 Office 100 East Graham Ave PRYOR OK 74361	2022-03-01 77002	2022-04-01 77337	0	335	
						335	
			ALLOWANCE	EXCESS USAGE		RATE	CHARGE
			1000	0		0.014600	\$0.00

LEAF
P.O. BOX 5066
HARTFORD, CT 06102-5066

866-219-7924

Address Service Requested

Please provide address/contact changes on the reverse side.

Remittance Section

Contract Number: 100-4111989-001
Invoice Number: 13208452
Invoice Due Date: 06/01/2022
Current Invoice Due:
Total Amount Due: \$ ~~349.71~~
Amount Remitted: \$ **349.71**

Payments received after 05/07/2022 are not reflected on this invoice.

Use enclosed envelope and make payable to:

3722010631 PRESORT PBPS027



PRYOR AREA CHAMBER OF COMMERCE
PO BOX 367
PRYOR OK 74362-0367

LEAF
P.O. BOX 5066
HARTFORD, CT 06102-5066



011004111989001000094695300132084520000349713

Keep lower portion for your records - Please return upper portion with your payment

LEAF
P.O. BOX 5066
HARTFORD, CT 06102-5066

Account Name: Pryor Area Chamber Of Commerce Contract Number: 100-4111989-001
Invoice Date: 05/07/2022 Invoice Number: 13208452
Invoice Due Date: 06/01/2022 Total Due: \$349.71

Important Messages

We're excited to announce that as of April 2, 2022, our parent company, People's United Bank, N.A., has merged into M&T Bank.

As a subsidiary of M&T Bank, we'll still be the same LEAF you've come to rely on, and you can continue to count on outstanding service and support from the team you know and trust.

acct # 15500 - ACH

IDENTIFICATION NUMBER	DESCRIPTION	PAYMENT	SALESUSE TAX	LATE CHARGES	TOTAL
Contract Number 100-4111989-001	Xerox C8045HX Copier System P.O.NUM: ACH-DO NOT PAY DATE DUE 06/01/22 COLOR	\$280.55	\$21.20		\$301.75
	DATE DUE 06/01/22 INSURANCE	\$28.19	\$2.79		\$30.98
	DATE DUE 06/01/22	\$16.98			\$16.98
PLEASE PAY THIS AMOUNT					\$349.71

LEAF
P.O. BOX 5066
HARTFORD, CT 06102-5066

Account Name:
Invoice Date:
Invoice Due Date:

Pryor Area Chamber Of Commerce
05/07/2022
06/01/2022

Contract Number:
Invoice Number:
Total Due:

100-4111989-001
13208452
\$349.71



Usage Report

Usage Profile Name	Meter Type Make / Model / Serial	Reference # / Contract # Location	Previous Date Previous Meter	Current Date Current Meter	Usage Credits	USAGE	
Color (Continued)	Color Xerox C8045 8TB555565	100-4111989-001 Office 100 East Graham Ave PRYOR OK 74361	2022-04-01 40480	2022-05-01 41105	0	625	
						625	
			ALLOWANCE	EXCESS USAGE		RATE	CHARGE
			350	275		0.102500	\$28.19
Mono	B&W Xerox C8045 8TB555565	100-4111989-001 Office 100 East Graham Ave PRYOR OK 74361	2022-04-01 77337	2022-05-01 77960	0	623	
						623	
			ALLOWANCE	EXCESS USAGE		RATE	CHARGE
			1000	0		0.014600	\$0.00

baac
PRYOR AREA
CHAMBER OF COMMERCE

Pryor Area Chamber of Commerce
100 E. Graham Ave.
Pryor, OK 74361
918.825.0157
info@pryorchamber.com

MEMBERCLICKS

Check #	Description	Amount
ACH	Software Renewal (July 2021)	\$ 267.41
ACH	Software Renewal (August 2021)	\$ 267.41
ACH	Domain Renewal	\$ 36.75
ACH	Software Renewal (September 2021)	\$ 267.41
ACH	Software Renewal (October 2021)	\$ 267.41
ACH	Software Renewal (November 2021)	\$ 267.41
ACH	Software Renewal (December 2021)	\$ 267.41
ACH	Software Renewal (January 2022)	\$ 280.79
ACH	Software Renewal (February 2022)	\$ 280.79
ACH	Software Renewal (March 2022)	\$ 280.78
ACH	Software Renewal (April 2022)	\$ 280.78
ACH	Software Renewal (May 2022)	\$ 280.78
ACH	Software Renewal (June 2022)	\$ 280.78
TOTAL		\$ 3,325.91

MemberClicks

3495 Piedmont Road NE
Building 11, Suite 800
Atlanta, GA 30305
Ph: 404-879-2844

Invoice #: CINV-042303
Invoice Date: 07/01/2021
Due Date: 07/01/2021
Terms: DOR
Customer ID: C01238
Customer PO:

Bill To:
Pryor Area Chamber of Commerce
PO Box 367
Pryor, OK 74362

Ship To:
Pryor Area Chamber of Commerce
PO Box 367
Pryor, OK 74362

Message

Item	Description	Unit	Quantity	Unit Price	Amount
WLC-Accelerate	WLC - Accelerate	Each	1	\$267.41	\$267.41
SUBTOTAL					\$267.41
Sales Tax					\$0.00
TOTAL					\$267.41
PAYMENTS/CREDITS APPLIED					\$0.00
BALANCE DUE					\$267.41



Kaite Thibodeaux <k...@pryorchamber.com>

MemberClicks LLC Order Receipt

1 message

MemberClicks <billing@memberclicks.com>
To: katie@pryorchamber.com

Wed, Jul 7, 2021 at 3:28 PM



Phone 800.914.2441
Fax 404.879.0017
Support 404.879.2800
3495 Piedmont Road NE
Building 11, Suite 800
Atlanta, GA 30305



Customer Number: C01238
Customer Name: Pryor Area Chamber of Commerce
Invoice Number: CP-20210707132811819
Invoice Date: 7/7/2021 4:28:12 PM -04:00
Due On: 7/8/2021 3:00:00 AM -04:00
Description: 156209

MemberClicks
3495 Piedmont Road NE
Building 11, Suite 800
Atlanta, GA 30305
(800) 914-2441

Item	Display Name	Price	Quantity	Discount	Sales Tax	Extended	Total
WLC-Accelerate	WLC - Accelerate	267.41	1	0.00		267.41	\$267.41
Payment Information							000001
Authorization Number							#####1004
Account Number							ACH
Card Type							Pryor Area Chamber of Commerce
Account/Card Holder Name							
AVS							
CVV							
Transaction Type:							Sale
Entry Method:							Keyed



495 Piedmont Road NE
 Building 11, Suite 800
 Atlanta, GA 30305
 Ph: 404-879-2844

Invoice #: CINV-043309
Invoice Date: 08/01/2021
Due Date: 08/01/2021
Terms: DOR
Customer ID: C01238
Customer PO:

Bill To:
 Pryor Area Chamber of Commerce
 PO Box 367
 Pryor, OK 74362

Ship To:
 Pryor Area Chamber of Commerce
 PO Box 367
 Pryor, OK 74362

Message

Item	Description	Unit	Quantity	Unit Price	Amount
WLC-Accelerate	WLC - Accelerate	Each	1	\$267.41	\$267.41
SUBTOTAL					\$267.41
Sales Tax					\$0.00
TOTAL					\$267.41
PAYMENTS/CREDITS APPLIED					\$0.00
BALANCE DUE					\$267.41



Katie Thibodeaux <Katie@pryorchamber.com>

MemberClicks LLC Order Receipt

1 message

MemberClicks <billing@memberclicks.com>
To: katie@pryorchamber.com

Sun, Aug 1, 2021 at 10:24 PM



Phone 800.914.2441
Fax 404.879.0017
Support 404.879.2800
3495 Piedmont Road NE
Building 11, Suite 800
Atlanta, GA 30305



MemberClicks
3495 Piedmont Road NE
Building 11, Suite 800
Atlanta, GA 30305
(800) 914-2441

Customer Number: C01238
Customer Name: Pryor Area Chamber of Commerce

Invoice Number: CINV-043309

Invoice Date: 8/1/2021 11:24:48 PM -04:00

Due On: 8/1/2021 3:00:00 AM -04:00

Description: Contract Invoice-CINV-043309

PO Box 387
Pryor OK 74362
(918) 825-0157
Item
WLC-Accelerate

Display Name
WLC - Accelerate

Price
267.41

Quantity
1

Discount
0.00

Sales Tax

Extended
267.41
0.00
Total: \$267.41

Payment Information
Authorization Number
Account Number
Card Type
Account/Card Holder Name
AVS
CVV
Transaction Type:
Entry Method:

000001
#####1004
ACH
Pryor Area Chamber of Commerce

Sale
Keyed



495 Piedmont Road NE
Building 11, Suite 800
Atlanta, GA 30305
Ph: 404-879-2844

Invoice #: CINV-043310
Invoice Date: 08/01/2021
Due Date: 08/01/2021
Terms: DOR
Customer ID: C01238
Customer PO:

Bill To:
Pryor Area Chamber of Commerce
PO Box 367
Pryor, OK 74362

Ship To:
Pryor Area Chamber of Commerce
PO Box 367
Pryor, OK 74362

Message

Item	Description	Unit	Quantity	Unit Price	Amount
Domain Renew	Domain Renewal	Each	1	\$36.75	\$36.75
SUBTOTAL					\$36.75
Sales Tax					\$0.00
TOTAL					\$36.75
PAYMENTS/CREDITS APPLIED					\$0.00
BALANCE DUE					\$36.75



Katie Thibodeaux <katie@pryorchamber.com>

MemberClicks LLC Order Receipt

1 message

MemberClicks <billing@memberclicks.com>
To: katie@pryorchamber.com

Tue, Aug 3, 2021 at 12:01 AM



Phone 800.914.2441
Fax 404.879.0017
Support 404.879.2800
3495 Piedmont Road NE
Building 11, Suite 800
Atlanta, GA 30305



Customer Number: C01238
Customer Name: Pryor Area Chamber of Commerce
Invoice Number: CINV-043310
Invoice Date: 8/3/2021 1:01:06 AM -04:00
Due On: 8/1/2021 3:00:00 AM -04:00
Description: Contract Invoice-CINV-043310

MemberClicks
3495 Piedmont Road NE
Building 11, Suite 800
Atlanta, GA 30305
(800) 914-2441

PO Box 367
Pryor OK 74362
(918) 825-0157

Item Domain Renewal
Display Name Domain Renewal

Price 36.75
Quantity 1

Discount 0.00

Sales Tax

Extended 36.75
Total: \$36.75

Payment Information
Authorization Number
Account Number
Card Type
Account/Card Holder Name
AVS
CVV
Transaction Type:
Entry Method:

000001
#####1004
ACH
Pryor Area Chamber of Commerce
Sale
Keyed



195 Piedmont Road NE
 Building 11, Suite 800
 Atlanta, GA 30305
 Ph: 404-879-2844

Invoice #: CINV-044335
Invoice Date: 09/01/2021
Due Date: 09/01/2021
Terms: DOR
Customer ID: C01238
Customer PO:

Please note our remit to address has changed to:

Payments via US Postal Service
 MemberClicks, LLC
 P.O. Box 736054
 Dallas, TX 75373-6054

Overnight information
 JPMorgan Chase
 TX1-0029
 MemberClicks 736054
 14800 Frye Rd., 2nd Floor
 Ft. Worth, TX 76155

Bill To:
 Pryor Area Chamber of Commerce
 PO Box 367
 Pryor, OK 74362

Ship To:
 Pryor Area Chamber of Commerce
 PO Box 367
 Pryor, OK 74362

Message

Item	Description	Unit	Quantity	Unit Price	Amount
WLC-Accelerate	WLC - Accelerate	Each	1	\$267.41	\$267.41
SUBTOTAL					\$267.41
Sales Tax					\$0.00
TOTAL					\$267.41
PAYMENTS/CREDITS APPLIED					\$0.00
BALANCE DUE					\$267.41



MemberClicks LLC Order Receipt

1 message

MemberClicks <billing@memberclicks.com>
To: katie@pryorchamber.com

Wed, Sep 1, 2021 at 6:20 AM



Phone 800.914.2441
Fax 404.879.0017
Support 404.879.2800
 3495 Piedmont Road NE
 Building 11, Suite 800
 Atlanta, GA 30305



Customer Number: C01238
Customer Name: Pryor Area Chamber of Commerce
Invoice Number: CINV-044335
Invoice Date: 9/1/2021 7:19:21 AM -04:00
Due On: 9/1/2021 3:00:00 AM -04:00
Description: Contract Invoice-CINV-044335

MemberClicks
3495 Piedmont Road NE
Building 11, Suite 800
Atlanta, GA 30305
(800) 914-2441

PO Box 367
 Pryor OK 74362
 (918) 825-0157

Item: WLC-Accelerate
 Display Name: WLC - Accelerate

Payment Information
 Authorization Number
 Account Number
 Card Type
 Account/Card Holder Name
 AVS
 CVV
 Transaction Type:
 Entry Method:

Quantity	Price	Discount	Extended
1	267.41	0.00	267.41
			Total: \$267.41

000001
 #####1004
 ACH
 Pryor Area Chamber of Commerce

Sale
 Keyed



195 Piedmont Road NE
 Building 11, Suite 800
 Atlanta, GA 30305
 Ph: 404-879-2844

Invoice #: CINV-045431
Invoice Date: 10/01/2021
Due Date: 10/01/2021
Terms: DOR
Customer ID: C01238
Customer PO:

Please note our remit to address has changed to:

Payments via US Postal Service

MemberClicks, LLC
 P.O. Box 736054
 Dallas, TX 75373-6054

Overnight information

JPMorgan Chase
 TX1-0029
 MemberClicks 736054
 14800 Frye Rd., 2nd Floor
 Ft. Worth, TX 76155

Bill To:

Pryor Area Chamber of Commerce
 PO Box 367
 Pryor, OK 74362

Ship To:

Pryor Area Chamber of Commerce
 PO Box 367
 Pryor, OK 74362

Message

acct. # 127400

Item	Description	Unit	Quantity	Unit Price	Amount
WLC-Accelerate	WLC - Accelerate	Each	1	\$267.41	\$267.41
SUBTOTAL					\$267.41
Sales Tax					\$0.00
TOTAL					\$267.41
PAYMENTS/CREDITS APPLIED					\$0.00
BALANCE DUE					\$267.41



Kaite Thibodeaux <kaite@pryorchamber.com>

MemberClicks LLC Order Receipt

1 message

MemberClicks <billing@memberclicks.com>
To: kaite@pryorchamber.com

Fri, Oct 1, 2021 at 12:00 PM



Phone 800.914.2441
Fax 404.879.0017
Support 404.879.2800
 3495 Piedmont Road NE
 Building 11, Suite 800
 Atlanta, GA 30305

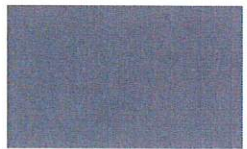

Customer Number: C01238
Customer Name: Pryor Area Chamber of Commerce
Invoice Number: CINV-045431
Invoice Date: 10/1/2021 12:58:46 PM -04:00
Due On: 10/1/2021 3:00:00 AM -04:00
Description: Contract Invoice-CINV-045431

MemberClicks
3495 Piedmont Road NE
Building 11, Suite 800
Atlanta, GA 30305
(800) 914-2441

PO Box 367
 Pryor OK 74362
 (918) 825-0157

Item WLC-Accelerate
Display Name WLC - Accelerate

Payment Information
 Authorization Number
 Account Number
 Card Type
 Account/Card Holder Name
 AVS
 CVV
 Transaction Type:
 Entry Method:

Quantity	Price	Discount	Sales Tax	Extended
1	267.41	0.00		267.41
				0.00
				Total: \$267.41

00001
 #####1004
 ACH
 Pryor Area Chamber of Commerce
 Sale
 Keyed



195 Piedmont Road NE
 Building 11, Suite 800
 Atlanta, GA 30305
 Ph: 404-879-2844

Invoice #: CINV-046579
Invoice Date: 11/01/2021
Due Date: 11/01/2021
Terms: DOR
Customer ID: C01238
Customer PO:

Please note our remit to address has changed to:

Payments via US Postal Service
 MemberClicks, LLC
 P.O. Box 736054
 Dallas, TX 75373-6054

Overnight information
 JPMorgan Chase
 TX1-0029
 MemberClicks 736054
 14800 Frye Rd., 2nd Floor
 Ft. Worth, TX 76155

Bill To:
 Pryor Area Chamber of Commerce
 PO Box 367
 Pryor, OK 74362

Ship To:
 Pryor Area Chamber of Commerce
 PO Box 367
 Pryor, OK 74362

Message

Item	Description	Unit	Quantity	Unit Price	Amount
WLC-Accelerate	WLC - Accelerate	Each	1	\$267.41	\$267.41
SUBTOTAL					\$267.41
Sales Tax					\$0.00
TOTAL					\$267.41
PAYMENTS/CREDITS APPLIED					\$0.00
BALANCE DUE					\$267.41



MemberClicks LLC Order Receipt

1 message

MemberClicks <billing@memberclicks.com>
To: katie@pryorchamber.com

Mon, Nov 1, 2021 at 6:15 AM



Phone 800.914.2441
Fax 404.879.0017
Support 404.879.2800
3495 Piedmont Road NE
Building 11, Suite 800
Atlanta, GA 30305



Customer Number: C01238
Customer Name: Pryor Area Chamber of Commerce
Invoice Number: CINV-046579
Invoice Date: 11/1/2021 7:11:55 AM -04:00
Due On: 11/1/2021 3:00:00 AM -04:00
Description: Contract Invoice-CINV-046579

MemberClicks
3495 Piedmont Road NE
Building 11, Suite 800
Atlanta, GA 30305
(800) 914-2441

PO Box 367
Pryor OK 74352
(918) 825-0157

Item WLC-Accelerate
Display Name WLC - Accelerate

Price 267.41
Quantity 1

Discount 0.00

Sales Tax

Extended 267.41
Total: \$267.41

Payment Information
Authorization Number
Account Number
Card Type
Account/Card Holder Name
AVS
CVV
Transaction Type:
Entry Method:

000001
#####1004
ACH
Pryor Area Chamber of Commerce

Sale Keyed



495 Piedmont Road NE
 Building 11, Suite 800
 Atlanta, GA 30305
 Ph: 404-879-2844

Invoice #: CINV-047460
Invoice Date: 12/01/2021
Due Date: 12/01/2021
Terms: DOR
Customer ID: C01238
Customer PO:

Please note our remit to address has changed to:

Payments via US Postal Service

MemberClicks, LLC
 P.O. Box 736054
 Dallas, TX 75373-6054

Overnight information

JPMorgan Chase
 TX1-0029
 MemberClicks 736054
 14800 Frye Rd., 2nd Floor
 Ft. Worth, TX 76155

Bill To:

Pryor Area Chamber of Commerce
 PO Box 367
 Pryor, OK 74362

Ship To:

Pryor Area Chamber of Commerce
 PO Box 367
 Pryor, OK 74362

Message

Item	Description	Unit	Quantity	Unit Price	Amount
WLC-Accelerate	WLC - Accelerate	Each	1	\$267.41	\$267.41
SUBTOTAL					\$267.41
Sales Tax					\$0.00
TOTAL					\$267.41
PAYMENTS/CREDITS APPLIED					\$0.00
BALANCE DUE					\$267.41



Katie Thibodeaux <katie@pryorchamber.com>

MemberClicks LLC Order Receipt

1 message

MemberClicks <billing@memberclicks.com>
katie@pryorchamber.com

Thu, Dec 2, 2021 at 8:50 PM



Phone 800.914.2441
Fax 404.879.0017

Support 404.879.2800

3495 Piedmont Road NE
Building 11, Suite 800
Atlanta, GA 30305

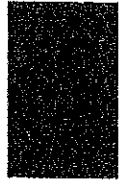

MemberClicks
3495 Piedmont Road NE
Building 11, Suite 800
Atlanta, GA 30305
(800) 914-2441

Customer Number: C01238
Customer Name: Pryor Area Chamber of Commerce
Invoice Number: CINV-047480
Invoice Date: 12/2/2021 7:47:11 PM -05:00
Due On: 12/1/2021 3:00:00 AM -05:00
Description: Contract Invoice-CINV-047480

PO Box 367
Pryor OK 74362
(918) 825-0157

Item	Display Name	Price	Quantity	Discount	Extended	Sales Tax
WLC-Accelorate	WLC - Accelorate	267.41	1	0.00	267.41	0.00
						Total: \$267.41

Payment Information
 Authorization Number
 Account Number
 Card Type
 Account/Card Holder Name
 AVS
 CVV
 Transaction Type:
 Entry Method:

000001
 #####1004
 ACH
 Pryor Area Chamber of Commerce
 Sales
 Keycard



195 Piedmont Road NE
 Building 11, Suite 800
 Atlanta, GA 30305
 Ph: 404-879-2844

Invoice #: CINV-048563
Invoice Date: 01/01/2022
Due Date: 01/01/2022
Terms: DOR
Customer ID: C01238
Customer PO:

Please note our remit to address has changed to:

Payments via US Postal Service
 MemberClicks, LLC
 P.O. Box 736054
 Dallas, TX 75373-6054

Overnight information
 JPMorgan Chase
 TX1-0029
 MemberClicks 736054
 14800 Frye Rd., 2nd Floor
 Ft. Worth, TX 76155

Bill To:
 Pryor Area Chamber of Commerce
 PO Box 367
 Pryor, OK 74362

Ship To:
 Pryor Area Chamber of Commerce
 PO Box 367
 Pryor, OK 74362

Message

Item	Description	Unit	Quantity	Unit Price	Amount
WLC-Accelerate	WLC - Accelerate	Each	1	\$280.79	\$280.79
SUBTOTAL					\$280.79
Sales Tax					\$0.00
TOTAL					\$280.79
PAYMENTS/CREDITS APPLIED					\$0.00
BALANCE DUE					\$280.79



Katie Thibodeaux <@pryorchamber.com>

MemberClicks LLC Order Receipt

1 message

MemberClicks <billing@memberclicks.com>
To: katie@pryorchamber.com

Sat, Jan 1, 2022 at 6:15 AM



Phone 800.914.2441
Fax 404.879.0017
Support 404.879.2800
3495 Piedmont Road NE
Building 11, Suite 800
Atlanta, GA 30305



Customer Number: C01238
Customer Name: Pryor Area Chamber of Commerce
Invoice Number: CINV-048563
Invoice Date: 1/1/2022 7:11:04 AM -05:00
Due On: 1/1/2022 3:00:00 AM -05:00
Description: Contract Invoice-CINV-048563

MemberClicks
3495 Piedmont Road NE
Building 11, Suite 800
Atlanta, GA 30305
(800) 914-2441

PO Box 367

Pryor OK 74362

(918) 825-0157

Item
WLC-Accelerate

Payment Information
Authorization Number
Account Number
Card Type
Account/Card Holder Name
AVS
CVV

Transaction Type:
Entry Method:

Display Name
WLC - Accelerate

Price
280.79

Quantity
1

Discount
0.00

Sales Tax

Extended
280.79
0.00
Total: \$280.79

000001
#####1004
ACH
Pryor Area Chamber of Commerce

Sale
Keyed

PRYOR AREA
CHAMBER OF COMMERCE, INC.
P.O. BOX 367
PRYOR, OK 74362

BUILDING A BETTER COMMUNITY TODAY - FOR TOMMORROW

RCB BANK
P.O. Box 8 Pryor, OK 74362
(918)825-4321 Member FDIC

018820

AY **** TWO HUNDRED EIGHTY & 79/100 DOLLARS

TO THE
ORDER OF:

DATE
01/05/22

AMOUNT
\$ **280.79

Member Clicks
3495 Piedmont Road NE
Building 11, Suite 800
Atlanta, GA 30305

VOID AFTER 90 DAYS

AUTHORIZED SIGNATURE



⑈018820⑈ ⑆1031⑆2594⑆ 04000121004⑈

PRYOR AREA CHAMBER OF COMMERCE, INC.

018820

Vendor ID: MEMBER C

Name: Member Clicks
Check Date:
Check Amount:

01/05/22
280.79

MEMO:

Customer ID: C01238
Invoice #CINV-048563

PRYOR AREA CHAMBER OF COMMERCE, INC.

018820

Vendor ID: MEMBER C

Name: Member Clicks
Check Date:
Check Amount:

01/05/22
280.79

MEMO:

Customer ID: C01238
Invoice #CINV-048563



2495 Piedmont Road NE
 Building 11, Suite 800
 Atlanta, GA 30305
 Ph: 404-879-2844

Invoice #: CINV-049667
Invoice Date: 02/01/2022
Due Date: 02/01/2022
Terms: DOR
Customer ID: C01238
Customer PO:

Please note our remit to address has changed to:

Payments via US Postal Service
 MemberClicks, LLC
 P.O. Box 736054
 Dallas, TX 75373-6054

Overnight information
 JPMorgan Chase
 TX1-0029
 MemberClicks 736054
 14800 Frye Rd., 2nd Floor
 Ft. Worth, TX 76155

Bill To:
 Pryor Area Chamber of Commerce
 PO Box 367
 Pryor, OK 74362

Ship To:
 Pryor Area Chamber of Commerce
 PO Box 367
 Pryor, OK 74362

Message

acct. # 127400 - ACH receipt attached

Item	Description	Unit	Quantity	Unit Price	Amount
WLC-Accelerate	WLC - Accelerate	Each	1	\$280.79	\$280.79
SUBTOTAL					\$280.79
Sales Tax					\$0.00
TOTAL					\$280.79
PAYMENTS/CREDITS APPLIED					\$0.00
BALANCE DUE					\$280.79



MemberClicks LLC Order Receipt

1 message

MemberClicks - billing@memberclicks.com
To: katie@pryorchamber.com

Katie Thibodeaux - katie@pryorchamber.com

Tue, Feb 1, 2022 at 8:45 AM

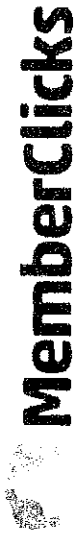

Phone 800.914.2441
Fax 404.879.0017
Support 404.879.2800
3495 Piedmont Road NE
Building 11, Suite 800
Atlanta, GA 30305



Customer Number: C01238
Customer Name: Pryor Area Chamber of Commerce
Invoice Number: CINVA049867
Invoice Date: 2/1/2022 9:44:46 AM -05:00
Due On: 2/1/2022 3:00:00 AM -05:00
Description: Contract Invoices-CINVA049867

MemberClicks
3495 Piedmont Road NE
Building 11, Suite 800
Atlanta, GA 30305
(800) 914-2441

PO Box 367
Pryor OK 74362
(918) 825-0157

Item: WLC-Accelerate
Display Name: WLC - Accelerate
Price: 280.79
Quantity: 1
Discount: 0.00
Sales Tax
Extended: 280.79
Total: 280.79
Payment Information
Authorization Number: 000001
Account Number: #####1004
Card Type: ACH
Account/Card Holder Name: Pryor Area Chamber of Commerce
AVS: CVV
Transaction Type: Sale
Entry Method: Koyed



Invoice

Bill To:

Pryor Area Chamber of Commerce
 PO Box 367
 Pryor OK 74362
 United States

Invoice #: INVMT-50668
Invoice Date: 1/1/2022
Due Date: 1/1/2022

To pay by check, Remit Payment To:	
Payment via US Postal Service:	MemberClicks, LLC P.O. Box 736054 Dallas, TX 75373-6054
Payments via Overnight Courier (FedEx, UPS, etc.):	JPMorgan Chase (TX1-0029) Attn: MemberClicks #736054 14800 Frye Rd., 2nd Floor Ft. Worth, TX 76155

To pay by credit card or ACH, please use the link below or reach out to billing@memberclicks.com to adjust or review autopay details.

Project Name:

PO#: MemberClicks - Contract Conversion

Month of Service: March

Invoice Description: Delivery: All software to be electronically delivered, and no tangible medium for software will be provided. Late charges will be assessed monthly on unpaid balances per Terms.

Item	Subscription Start Date	Subscription End Date	Amount
account # 127400 MC Trade	1/1/2022	12/31/2022	\$280.78

Subtotal	\$280.78
Tax Total (%)	\$0.00
Total	\$280.78
Payments/Credits	\$0.00
Balance Due	\$280.78



Invoice

Bill To:
 Pryor Area Chamber of Commerce
 PO Box 367
 Pryor OK 74362
 United States

Invoice #: INVMT-50846
Invoice Date: 3/1/2022
Due Date: 4/30/2022

To pay by check, Remit Payment To:	
Payment via US Postal Service:	MemberClicks, LLC P.O. Box 736054 Dallas, TX 75373-6054
Payments via Overnight Courier (FedEx, UPS, etc.):	JPMorgan Chase (TX1-0029) Attn: MemberClicks #736054 14800 Frye Rd., 2nd Floor Ft. Worth, TX 76155

To pay by credit card or ACH, please use the link below or reach out to billing@memberclicks.com to adjust or review autopay details.

Month of Service: April

Invoice Description: Delivery: All software to be electronically delivered, and no tangible medium for software will be provided. Late charges will be assessed monthly on unpaid balances per Terms.

Item	Subscription Start Date	Subscription End Date	Amount
MC Trade acct. # 127400	1/1/2022	12/31/2022	\$280.78
		Subtotal	\$280.78
		Tax Total (%)	\$0.00
		Total	\$280.78
		Payments/Credits	\$0.00
		Balance Due	\$280.78





Invoice

Bill To:
C3828 Pryor Area Chamber of Commerce

Invoice #: INVMT-50940
Invoice Date: 4/1/2022
Due Date: 5/31/2022

To pay by check, Remit Payment To:	
Payment via US Postal Service:	MemberClicks, LLC P.O. Box 736054 Dallas, TX 75373-6054
Payments via Overnight Courier (FedEx, UPS, etc.):	JPMorgan Chase (TX1-0029) Attn: MemberClicks #736054 14800 Frye Rd., 2nd Floor Ft. Worth, TX 76155

If you are enrolled in autopay, payment will be withdrawn from the payment method below on **5/31/2022**.

Autopay details: Payment Method - **ACH xxxx4**

If you are not enrolled in autopay, to pay by credit card or ACH, please use the **"PAY NOW"** link below or send a check to the remittance address above.

Reach out to billing@memberclicks.com to update your autopayment method or enroll in autopay.

Month of Service: May

PO#/Other Notes:

Invoice Description: Delivery: All software to be electronically delivered, and no tangible medium for software will be provided. Late charges will be assessed monthly on unpaid balances per Terms.

Item	Subscription Start Date	Subscription End Date	Amount
MC Trade	1/1/2022	12/31/2022	\$280.78
Subtotal			\$280.78
Tax Total (%)			\$0.00
Total			\$280.78
Payments/Credits			\$0.00
Balance Due			\$280.78



Invoice

Bill To:
C3828 Pryor Area Chamber of Commerce

Invoice #: INVMT-51027
Invoice Date: 5/1/2022
Due Date: 6/30/2022

To pay by check, Remit Payment To:	
Payment via US Postal Service:	MemberClicks, LLC P.O. Box 736054 Dallas, TX 75373-6054
Payments via Overnight Courier (FedEx, UPS, etc.):	JPMorgan Chase (TX1-0029) Attn: MemberClicks #736054 14800 Frye Rd., 2nd Floor Ft. Worth, TX 76155

If you are enrolled in autopay, payment will be withdrawn from the payment method below on **6/30/2022**.

Autopay details: Payment Method - **ACH xxxx4**

If you are not enrolled in autopay, to pay by credit card or ACH, please use the "**PAY NOW**" link below or send a check to the remittance address above.
Reach out to billing@memberclicks.com to update your autopayment method or enroll in autopay.

Month of Service: June

PO#/Other Notes:

Invoice Description: Delivery: All software to be electronically delivered, and no tangible medium for software will be provided. Late charges will be assessed monthly on unpaid balances per Terms.

Item	Subscription Start Date	Subscription End Date	Amount
MC Trade	1/1/2022	12/31/2022	\$280.78
		Subtotal	\$280.78
		Tax Total (%)	\$0.00
		Total	\$280.78
		Payments/Credits	\$0.00
		Balance Due	\$280.78

S&J Storage & Rentals

PO Box 793
 Pryor, OK 74362

Statement

Date
8/23/2023

To:
Pryor Area Foundation PO Box 367 Pryor, OK 74362

		Amount Due	Amount Enc.		
		\$0.00			
Date	Transaction	Amount	Balance		
06/30/2021	Balance forward		0.00		
07/01/2021	INV #2929. Due 07/01/2021.	65.00	65.00		
07/01/2021	PMT	-65.00	0.00		
08/01/2021	INV #2972. Due 08/01/2021.	65.00	65.00		
08/02/2021	PMT	-65.00	0.00		
09/01/2021	INV #3017. Due 09/01/2021.	65.00	65.00		
09/08/2021	PMT	-65.00	0.00		
10/01/2021	INV #3063. Due 10/01/2021.	65.00	65.00		
10/01/2021	PMT #RBL166735685. ACCB (Recurring Payment)	-65.00	0.00		
11/01/2021	INV #3110. Due 11/01/2021.	65.00	65.00		
11/01/2021	PMT #RBL170622775. ACCB (Recurring Payment)	-65.00	0.00		
12/01/2021	INV #3164. Due 12/01/2021.	65.00	65.00		
12/01/2021	PMT #RBL174225545. ACCB (Recurring Payment)	-65.00	0.00		
01/01/2022	INV #3221. Due 01/01/2022.	65.00	65.00		
01/01/2022	PMT #RBL177970135. ACCB (Recurring Payment)	-65.00	0.00		
02/01/2022	INV #3273. Due 02/01/2022.	65.00	65.00		
02/01/2022	PMT #RBL181932005. ACCB (Recurring Payment)	-65.00	0.00		
03/01/2022	INV #3324. Due 03/01/2022.	65.00	65.00		
03/01/2022	PMT #RBL185516475. ACCB (Recurring Payment)	-65.00	0.00		
04/01/2022	INV #3379. Due 04/01/2022.	65.00	65.00		
04/01/2022	PMT #RBL189388615. ACCB (Recurring Payment)	-65.00	0.00		
05/01/2022	INV #3432. Due 05/01/2022.	65.00	65.00		
05/01/2022	PMT #RBL193064205. ACCB (Recurring Payment)	-65.00	0.00		
06/01/2022	INV #3486. Due 06/01/2022.	65.00	65.00		
06/01/2022	PMT #RBL196876825. ACCB (Recurring Payment)	-65.00	0.00		
CURRENT	1-30 DAYS PAST DUE	31-60 DAYS PAST DUE	61-90 DAYS PAST DUE	OVER 90 DAYS PAST DUE	Amount Due
0.00	0.00	0.00	0.00	0.00	\$0.00

8/23/2022
09:42

Pryor Area Chamber of Commerce
Cumulative General Ledger
From: 7/1/21 To: 12/31/22

Company: PCC
Page: 1

<u>Date</u>	<u>Mt</u>	<u>Reference</u>	<u>Account</u>	<u>Description</u>	<u>Current</u>	<u>Year-to-Date</u>
Beginning Balance			15800	Facility Rental		390.00*
7/2/21	7	CD7	15800	S&J Storage & Rentals LLC	65.00	
8/3/21	8	CD8	15800	S&J Storage & Rentals LLC	65.00	
9/9/21	9	CD9	15800	S&J Storage & Rentals LLC	65.00	
11/4/21	11	18780	15800	BOA/S&J Storage	65.00	
12/7/21	12	18796	15800	BOA/S&J Storage	65.00	
1/3/22	1	18814	15800	BOA/S&J Storage	65.00	
1/5/22	1	18817	15800	Open Door Venue	350.00	
2/2/22	2	18833	15800	BOA/S&J Storage	65.00	
3/8/22	3	18845	15800	BOA/S&J Storage	65.00	
4/6/22	4	18857	15800	BOA/S&J Storage	65.00	
4/27/22	4	18870	15800	BOA/S&J Storage	65.00	
6/30/22	6	JE1	15800	To Ret Ck#18817 Venue Deposit	-350.00	
6/7/22	6	18897	15800	BOA/S&J Storage	65.00	
7/5/22	7	18910	15800	BOA/S&J Storage	65.00	
				Ending Balance =	780.00*	1,170.00**

This is a partial G/L.

General Ledger is Out-of-Balance

1,170.00**

14 Transactions

Y-T-D Loss (1,170.00)

BARBARA K HAWKINS

SHIPPING ADDRESS

Barbara K Hawkins
100 E Graham Ave
Pryor, OK 74361-2439

PAYMENT INFORMATION

Billing Address Payment Method
Barbara K
Hawkins
Po Box 367
Pryor, OK
74362-0367
VISA
Visa ending in **41

DELIVERED

Order Id: 1837497236
Standard Ground
Shipping

HP 17.3" Touchscreen Pentium 12GB RAM
256GB SSD Laptop w/Office 365



ITEM 810-954
\$669.99
FREE SHIPPING
Rose Gold

Subtotal \$669.99
S&H \$0.00
Tax ? \$66.16
ORDER TOTAL \$736.15

BUY AGAIN

RETURN OPTIONS

EXCHANGE

TRACK ORDER

~~\$~~996.10

REFER & GET \$50 X

BARBARA K HAWKINS

SHIPPING ADDRESS

Barbara K Hawkins
100 E Graham Ave
Pryor, OK 74361-2439

PAYMENT INFORMATION

Billing Address Payment Method
Barbara K
Hawkins **VISA**
Po Box 367 Visa ending in **41
Pryor, OK
74362-0367

SHIPPED

Order Id: 1837497551
Estimated Delivery 3-7
Business Days
Standard Ground
Shipping

3-Year Laptop Computer HSN Protection
Plan \$600-\$699

ITEM 534-859
\$159.95
FREE SHIPPING

Subtotal	\$159.95
S&H	\$0.00
Tax (?)	\$0.00
ORDER TOTAL	\$159.95

REFER & GET \$50 X

BARBARA K HAWKINS

SHIPPING ADDRESS

Barbara K Hawkins
100 E Graham Ave
Pryor, OK 74361-2439

PAYMENT INFORMATION

Billing Address Payment Method
Barbara K
Hawkins
Po Box 367
Pryor, OK
74362-0367



MasterCard ending in
**74

DELIVERED

Order Id: 1837489327

Standard Ground
Shipping

HP 17.3" Touchscreen Pentium 12GB RAM
256GB SSD Laptop w/Office 365



ITEM 810-954
\$669.99
FREE SHIPPING
Blue

Subtotal	\$669.99
S&H	\$0.00
Tax (?)	\$66.16
ORDER TOTAL	\$736.15

BUY AGAIN

RETURN OPTIONS

EXCHANGE

TRACK ORDER

\$996.10

REFER & GET \$50 X

BARBARA K HAWKINS



SHIPPING ADDRESS

Barbara K Hawkins
100 E Graham Ave
Pryor, OK 74361-2439

PAYMENT INFORMATION

Billing Address Payment Method

Barbara K
Hawkins
Po Box 367
Pryor, OK
74362-0367



MasterCard ending in
**74

SHIPPED

Order Id: 1837490261
Estimated Delivery 3-7
Business Days
Standard Ground
Shipping

3-Year Laptop Computer HSN Protection
Plan \$600-\$699

Subtotal \$159.95
S&H \$0.00
Tax (?) \$0.00

ITEM 534-859
\$159.95
FREE SHIPPING

ORDER TOTAL \$159.95

REFER & GET \$50 X

PRYOR AREA CHAMBER OF COMMERCE

Pryor Area Chamber of Commerce
 100 E. Graham Ave.
 Pryor, OK 74361
 918.825.0157
 info@pryorchamber.com

MISCELLANEOUS

Check #	Payee	Description	Amount
18717	Pryor Main Street	Fundraiser Table	\$ 260.00
18719	Dell Business Credit	Monitor	\$ 208.75
18845	Business Card	Uline (Promo Wall Supplies)	\$ 799.41
18857	Business Card	Uline (Promo Wall Supplies)	\$ 116.53
18886	Rachel Jackson	Mayes County Shopping Guide Travel	\$ 159.76
18886	Rachel Jackson	Mayes County Shopping Guide Design Software	\$ 269.00
18895	The Book Exchange	The Oklahomans Vol. 2	\$ 400.00
18911	Katie Thibodeaux (for Rustin Thibodeaux)	Labor for Promotional Slat Wall	\$ 150.00
18910	Business Card	Home Depot (Promotional Slat Wall Supplies)	\$ 76.87
18910	Business Card	USPS PO Boxes Online	\$ 70.00
18910	Business Card	USPS PO Boxes Online	\$ 160.00
	Business Card	S&J Storage (Storage - Event Supplies) \$65.00x12 months	\$ 780.00
	Business Card	Laptop Computer for Volunteers (Order #183794727)	\$ 996.10
	Barbara Hawkins Reimbursement	Laptop Computer for Volunteers (Order #1837947236)	\$ 996.10
TOTAL			\$ 5,442.52



PRYOR MAIN STREET

8 South Vann Pryor, OK 74361

PO BOX 216 Pryor, OK 74362

mainstreetpryor@gmail.com

FR: Pryor Main Street

Invoice to:
Pryor Area Chamber of Commerce

Invoice Reason:
Fundraiser Table-DWTPS

Amount:
\$260

Invoice Number:
3322

Date:
7/13/21

acct # 125361

PRYOR AREA.
CHAMBER OF COMMERCE, INC.
 P.O. BOX 367 -
 PRYOR, OK 74362
 BUILDING A BETTER COMMUNITY TODAY - FOR TOMORROW.

RCB BANK
 P.O. Box 8 Pryor, OK 74362
 (516)826-4321 Member FDIC

018717

PAY ***** TWO HUNDRED SIXTY & 00/100 DOLLARS

DATE 07/21/21 AMOUNT \$ 280.00

TO THE ORDER OF
 Pryor Main Street
 8 South Veon
 Pryor, OK 74361

90 DAYS AFTER 90 DAYS

[Signature]
 ALTHEA B. COLKKA

RCB BANK
 P.O. BOX 8 PRYOR, OK 74362
 (516) 826-4321

CHAMBER OF COMMERCE, INC.
 P.O. BOX 367 PRYOR, OK 74362
 (516) 826-4321

MEMBER FDIC

① CHECK HERE IF MOBILE DEPOSIT
 (ACTIVATED FOR AN ONLINE INSTITUTION ONLY)

② CHECK HERE TO DEPOSIT TO THE ACCOUNT OF THE
 WITHDRAWN PAYEE
 RCB Bank

③ CHECK HERE TO DEPOSIT TO THE ACCOUNT OF THE
 WITHDRAWN PAYEE
 RCB Bank



Dell Business Credit

Account Number 6879 4502 0401 7473 582

For the billing period ending July 13, 2021

Special Messages for PRYOR AREA CHAMBER

Save big with exclusive SB Month offers and pay over time when using Dell Business Credit. Call (877) 289-3355 or visit www.Dell.com/DBC for more details.

Summary of Account Activity

Previous Balance	\$755.51	Statement Date	July 13, 2021
Payments & Credits	\$755.51	Credit Limit	\$10,000.00
Purchases/Other Charges	\$208.75	Available Credit Limit	\$9,791.25
Finance Charges	\$0.00	Amount Over Credit Limit	\$0.00
New Balance	\$208.75		
		Payment Due Date	August 07, 2021
		Current Month Minimum Payment	\$15.00
		Past Due Amount	\$0.00
		Minimum Payment Due	\$15.00

Finance Charge Summary

View a summary of the plan details for this plan.

Plan Type	Promotion Expiration Date	Balance Subject to Finance Charge	Daily Periodic Rate	Corresponding Interest Rate	Days in Cycle	Finance Charges	Promotion Plan Deferred Finance Charges	New Plan Balance	Minimum Amount Due Per Plan
Standard Plan	7/13/21	\$755.51	0.000000	0.000000	31	\$0.00	\$0.00	\$755.51	\$15.00
Standard Plan	7/13/21	\$208.75	0.000000	0.000000	31	\$0.00	\$0.00	\$208.75	\$15.00
Standard Plan	7/13/21	\$0.00	0.000000	0.000000	31	\$0.00	\$0.00	\$0.00	\$15.00

Finance charges are calculated on the outstanding balance of your account. Finance charges are calculated on the outstanding balance of your account. Finance charges are calculated on the outstanding balance of your account.

View a summary of the plan details for this plan. View a summary of the plan details for this plan. View a summary of the plan details for this plan.

000924 1/3



Dell Financial Services



Offered by WebBank, Member FDIC
Services by Dell Financial Services

Dell Business Credit

Account Number 6879 4502 0401 7473 582

The billing period ending July 13, 2021

Page 3 of 4

Transaction Detail

Transaction Date	Description	Detail	Amount
06-25-21	DELL PURCHASE - THANK YOU!	DELL #908441883	\$208.75
06-28-21	PAYMENT - THANK YOU		-\$755.51

000924 2/3

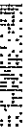

Dell Customer Service: (800) 624-9897
 Dell Technical Support: (800) 624-9896
 Dell Online: Dell.com

Customer Reference Number:
 Order Date: 06/02/21
 Order Number: 908441883

Account Number: 6879450204017473582
 DFS Customer Service: (866) 413-3355

SHIP TO:
 US529997422764
 BARBARA HAWKINS
 PO BOX 367
 PRYOR, 74362-0367

SHIP TO:
 PRYOR AREA CHAMBER OF COMMERCE
 KATIE THIBODEAUX
 100 EAST GRAHAM AVE
 PRYOR, OK 74361-2439

Ordered	Item Number	Description
1	210-AUNG	Dell 24 Monitor - E2420HS, 60.5cm (23.81
1	814-9340	Dell Limited Hardware Warranty
1	814-9341	Advanced Exchange Service, 3 Years

000924 3/3

Please use the enclosed Billing Statement to remit your monthly payment.

System Service Tag/Serial Number(s)
 86T70D3

Shipping and/or Handling	\$0.00
Subtotal	\$189.99
Tax	\$18.76
Order Total	\$208.75
DBC Financed Amount	\$208.75

000924 3/3

**PRYOR AREA
CHAMBER OF COMMERCE, INC.**

P.O. BOX 367
PRYOR, OK 74362

BUILDING A BETTER COMMUNITY TODAY - FOR TOMMORROW

018719

RCB BANK

P.O. Box 8 Pryor, OK 74362
(918)825-4321 Member FDIC

PAY **** TWO HUNDRED EIGHT & 75/100 DOLLARS

TO THE
ORDER OF:

DATE 07/26/21 AMOUNT \$ **208.75

Dell Business Credit
Payment Processing Center
PO Box 5275
Carol Stream, IL 60197

VOID AFTER 90 DAYS

[Handwritten Signature]
AUTHORIZED SIGNATURE

⑈018719⑈ ⑆103112594⑆ 04000121004⑈

PRYOR AREA CHAMBER OF COMMERCE, INC.

018719

Vendor ID: DELL

Name: Dell Business Credit
Check Date: 07/26/21
Check Amount: 208.75

PRYOR AREA CHAMBER OF COMMERCE, INC.

018719

Vendor ID: DELL

Name: Dell Business Credit
Check Date: 07/26/21
Check Amount: 208.75



PRYOR AREA CHMBR OF COMM

January 19, 2022 - February 18, 2022

Page 3 of 8

Transactions

Posting Date	Transaction Date	Description	Reference Number	Amount
02/10	02/09	PAYMENT - THANK YOU	0411530000000531119053	
TOTAL PAYMENTS AND OTHER CREDITS FOR THIS PERIOD				

HAWKINS, BARBARA
Account Number: 1774

01/31	01/29	TOTAL PAYMENTS AND OTHER CREDITS FOR THIS PERIOD			
Purchases and Other Charges					

01/27	01/27	ULINE *SHIP SUPPLIES 800-295-5510 WI	55432862027200260941042	799.41
-------	-------	--------------------------------------	-------------------------	--------

TOTAL PURCHASES AND OTHER CHARGES FOR THIS PERIOD

Finance Charge Calculation

Annual Percentage Rate (APR) is the annual interest rate on your account.

	Annual Percentage Rate	Balance Subject to Interest Rate	Finance Charges by Transaction Type
PURCHASES		\$0.00	\$0.00
CASH		\$0.00	\$0.00

V = Variable Rate (rate may vary), Promotional Balance = APR for limited time on specified transactions.

Important Messages

YOUR FINANCE CHARGES IN 2021 WERE

Reward Summary

Beginning Balance		Other Bonuses
Earned		
Redeemed	.00	
Adjustments	.00	Ending Balance

To redeem your Cash Rewards call 1.800.673.1044, or visit www.bankofamerica.com

PRYOR AREA
CHAMBER OF COMMERCE, INC.

P.O. BOX 367
PRYOR, OK 74362

BUILDING A BETTER COMMUNITY TODAY - FOR TOMMORROW

RCB BANK
P.O. Box 8 Pryor, OK 74362
(918)825-4321 Member FDIC

018845

PAY ***** ONE THOUSAND ONE HUNDRED SEVENTY SEVEN & 55/100 DOLLARS

TO THE
ORDER OF:

DATE
03/08/22

AMOUNT
\$ **1177.55

Business Card
PO Box 15796
Wilmington, DE 19886

VOID AFTER 90 DAYS



AUTHORIZED SIGNATURE



⑈018845⑈ ⑆103112594⑆ 04000121004⑈

PRYOR AREA CHAMBER OF COMMERCE, INC.

018845

Vendor ID: BOFAMERICA

Name: Business Card

Check Date:

03/08/22

Check Amount:

1,177.55

MEMO:

Acct. # 5474976700308445

PRYOR AREA CHAMBER OF COMMERCE, INC.

018845

Vendor ID: BOFAMERICA

Name: Business Card

Check Date:

03/08/22

Check Amount:

1,177.55

MEMO:

Acct. # 5474976700308445



PRYOR AREA CHMBR OF COMM

February 19, 2022 - March 18, 2022

Page 3 of 4

Cardholder Activity Summary

Account Number	Credit Limit	Total Activity	Payments and Other Credits	Balance Transfer Activity	Cash Advance Activity	Purchases and Other Charges	Fees Charged
HAWKINS BARBARA			0.00	0.00	0.00		0.00

Transactions

Posting Date	Transaction Date	Description	Reference Number	Amount
PRYOR AREA CHMBR OF COMM				
Account Number: 8445				
		Payments and Other Credits		
03/11	03/10	PAYMENT - THANK YOU	07015300000000590765428	
		TOTAL PAYMENTS AND OTHER CREDITS FOR THIS PERIOD		
HAWKINS, BARBARA				
Account Number: 1774				
		Purchases and Other Charges		

03/18	03/18	ULINE *SHIP SUPPLIES 800-295-5510 WI	55432862077200281951342	116.53
		TOTAL PURCHASES AND OTHER CHARGES FOR THIS PERIOD		

Finance Charge Calculation

Your Annual Percentage Rate (APR) is the annual interest rate on your account.

	Annual Percentage Rate	Balance Subject to Interest Rate	Finance Charges by Transaction Type
PURCHASES		\$0.00	\$0.00
CASH		\$0.00	\$0.00

V = Variable Rate (rate may vary). Promotional Balance = APR for limited time on specified transactions.

Reward Summary

Beginning Balance		Other Bonuses
Earned		
Redeemed	.00	
Adjustments	.00	Ending Balance

To redeem your Cash Rewards call 1.800.673.1044, or visit www.bankofamerica.com

PRYOR AREA
CHAMBER OF COMMERCE, INC.

P.O. BOX 367
PRYOR, OK 74362

BUILDING A BETTER COMMUNITY TODAY - FOR TOMMORROW

RCB BANK

P.O. Box 8 Pryor, OK 74362
(918)825-4321 Member FDIC

018857

**** ONE THOUSAND TWO HUNDRED EIGHTY NINE & 6/100 DOLLARS

TO THE
ORDER OF:

DATE

04/06/22

AMOUNT

\$ **1289.06

Business Card
PO Box 15796
Wilmington, DE 19886

VOID AFTER 90 DAYS

Cholke
AUTHORIZED SIGNATURE



⑈018857⑈ ⑆103112594⑆ 04000121004⑈

PRYOR AREA CHAMBER OF COMMERCE, INC.

018857

Vendor ID: BOFAMERICA

Name: Business Card

Check Date:

04/06/22

Check Amount:

1,289.06

MEMO:

Acct. # 5474976700308445

PRYOR AREA CHAMBER OF COMMERCE, INC.

018857

Vendor ID: BOFAMERICA

Name: Business Card

Check Date:

04/06/22

Check Amount:

1,289.06

MEMO:

Acct. # 5474976700308445

Reimbursement Itemization

Payee: Rachel Jackson

Date Submitted: 5/13/2022

Date	Account Number	Amount	Memo
March - Current	126700 - Travel (Promotions)	\$159.76	Mayes County Shopping Guide Travel
4/24/2022	127400 - Web Services (Promotions)	\$269.00	Mayes County Shopping Guide Design Software

PRYOR AREA
CHAMBER OF COMMERCE, INC.

P.O. BOX 367
PRYOR, OK 74362

BUILDING A BETTER COMMUNITY TODAY - FOR TOMMORROW

RCB BANK

P.O. Box 8 Pryor, OK 74362
(918)825-4321 Member FDIC

018886

AY ***** SIX HUNDRED TWENTY ONE & 30/100 DOLLARS

TO THE
ORDER OF:

DATE

05/16/22

AMOUNT

\$ **621.30

Rachel Jackson

VOID AFTER 90 DAYS



AUTHORIZED SIGNATURE



⑈018886⑈ ⑆103112594⑆ 04000121004⑈

PRYOR AREA CHAMBER OF COMMERCE, INC.

018886

Vendor ID: JACKSON

Name: Rachel Jackson

Check Date:

05/16/22

Check Amount:

621.30

MEMO:

Various accts reimbursement

PRYOR AREA CHAMBER OF COMMERCE, INC.

018886

Vendor ID: JACKSON

Name: Rachel Jackson

Check Date:

05/16/22

Check Amount:

621.30

MEMO:

Various accts reimbursement

acct. # 125361
promotional expense

**THE BIBLE BOOKSTORE
THE BOOK EXCHANGE**

3 N. ADAIR ST.
PRYOR, OK 74361
(918) 825-6015

CUSTOMER'S ORDER NO.		PHONE		DATE	
				6-1-22	
NAME					
Pryor Area					
ADDRESS					
Commerce of Commerce					
CASH	G.O.D.	CHARGE	ON ACCT.	MOSE. RET'D.	PAID OUT
		<input checked="" type="checkbox"/>			
10		Oklahoma's	140.00		400.00
					TAX
SOLD BY		RECEIVED BY			

PRYOR AREA
CHAMBER OF COMMERCE, INC.
P.O. BOX 367
PRYOR, OK 74362

BUILDING A BETTER COMMUNITY TODAY - FOR TOMMORROW

RCB BANK
P.O. Box 8 Pryor, OK 74362
(918)825-4321 Member FDIC

018895

PAY **** FOUR HUNDRED & 0/100 DOLLARS

TO THE
ORDER OF:

The Book Exchange
3 North Adair Street
Pryor, OK 74361

DATE

AMOUNT

06/07/22

\$

**400.00

VOID AFTER 90 DAYS

[Handwritten Signature]
AUTHORIZED SIGNATURE



⑈018895⑈ ⑆103112594⑆ 04000121004⑈

PRYOR AREA CHAMBER OF COMMERCE, INC.

018895

Vendor ID: BOOK

Name: The Book Exchange

Check Date: 06/07/22

Check Amount: 400.00

MEMO:

6/1/22 Invoice
Oklahomans II (10)

PRYOR AREA CHAMBER OF COMMERCE, INC.

018895

Vendor ID: BOOK

Name: The Book Exchange

Check Date: 06/07/22

Check Amount: 400.00

MEMO:

6/1/22 Invoice
Oklahomans II (10)

INVOICE

Date: 6/29/22
INVOICE # 100

Pryor Chamber Area Chamber of Commerce
100 E Graham
Pryor, OK 74361

Katie Thibodeaux
(for Rustin Thibodeaux)
604 SE 17th St
Pryor, OK 74361

Qty	Description	Unit Price	Line Total
1	Hang Slat Wall for tourist info – bid by job	150.00	150.00

Subtotal
Sales Tax
Total 150.00

Make all checks payable to Company Name
Thank you for your business!

PRYOR AREA
CHAMBER OF COMMERCE, INC.

P.O. BOX 367
PRYOR, OK 74362

BUILDING A BETTER COMMUNITY TODAY - FOR TOMMORROW

RCB BANK

P.O. Box 8 Pryor, OK 74362
(918)825-4321 Member FDIC

018911

PAY **** ONE HUNDRED FIFTY & 0/100 DOLLARS

TO THE
ORDER OF:

DATE

AMOUNT

07/05/22

\$

**150.00

Katelyn M. Thibodeaux
604 SE 17th St.
Pryor, OK 74361

VOID AFTER 90 DAYS

[Handwritten Signature]
AUTHORIZED SIGNATURE



⑈018911⑈ ⑆103112594⑆ 04000121004⑈

PRYOR AREA CHAMBER OF COMMERCE, INC.

018911

Vendor ID: THIBODEAUX

Name: Katelyn M. Thibodeaux

Check Date: 07/05/22

Check Amount: 150.00

MEMO:

Carpentry work

PRYOR AREA CHAMBER OF COMMERCE, INC.

018911

Vendor ID: THIBODEAUX

Name: Katelyn M. Thibodeaux

Check Date: 07/05/22

Check Amount: 150.00

MEMO:

Carpentry work

nsactions

Posting Date	Transaction Date	Description	Reference Number	Amount
06/13	06/12	PAYMENT - THANK YOU	1641530000000571332179	
TOTAL PAYMENTS AND OTHER CREDITS FOR THIS PERIOD				

HAWKINS, BARBARA
 Account Number: 1774

06/13	06/10	HOMEDEPOT COM	800-430-3376 GA	52707152162010184001575	76.87
-------	-------	---------------	-----------------	-------------------------	-------

Your Annual Percentage Rate (APR) is the annual interest rate on your account

	Annual Percentage Rate	Balance Subject to Interest Rate	Finance Charges by Transaction Type
PURCHASES		\$0.00	\$0.00
CASH		\$0.00	\$0.00

V = Variable Rate (rate may vary) Promotional Balance = APR for limited time on specified transactions

Beginning Balance		Other Bonuses
Earned		
Redeemed	00	
Adjustments	00	Ending Balance

To redeem your Cash Rewards call 1 800 673 1044 or visit www.bankofamerica.com



Order #WP35568418

Placed on: May 23, 2022

Billing Information

Barbara Hawkins

Po Box 367

PRYOR OK 74362

Payment Method: MC ***1774

Item	Price/Item	Qty	Line Total
Ship To Home (1 item)			
100 E GRAHAM AVE , PRYOR, OK 74361			
ROPPE Saturn 0.75 in. Thick x 0.75 in. Wide x 94 in. Length Wood Quarter Round Molding	\$34.98	2	\$69.96

Expect it on Jun 13

Subtotal	\$69.96
Shipping	FREE
Sales Tax	\$6.91
Total	\$76.87
You Saved	\$5.99

Need help?

Online Customer Support:
1-800-430-3376

Call 7 days a week:
6 a.m. to 2 a.m. EST



Katie Thibodeaux <katie@pryorchamber.com>

USPS - PO Box Payment Received, Thank You

2 messages

donotreply@usps.com <donotreply@usps.com>

Thu, Jun 2, 2022 at 3:41 PM

To: katie@pryorchamber.com

**Hello KATELYN THIBODEAUX,**

Thank you for your payment to the USPS in the amount of \$70.00 for the PO Box listed below. This payment has been applied to your account and your credit or debit card has been charged.

Transaction number:	91002265303064
Payment amount:	\$70.00
Payment period:	12 months
Payment method:	MASTERCARD credit-card ✓
Next payment due:	06/30/2023
PO Box number:	1523
Post Office location:	111 S ADAIR ST PRYOR, OK 74361-9998

Take the stress out of remembering to make your next payment by signing up for our Automatic Renewal payment program. It's free, it's fast, and it's easy! Sign in at usps.com/poboxes and go to the Manage Your Account page. Then, click on Setup Auto Renewal under Next Payment Due. Be sure to review the Terms and Conditions governing automatic payments when you select this option.

Thank you for choosing the United States Postal Service[®]. We appreciate your business.

Please do not respond to this system-generated email.

If you need assistance with PO Boxes Online, please visit USPS [Help](#) or [Contact Us](#).

Download USPS Mobile[®]

Payment Successful

Your payment was successful.

Payment Received - PO Box™ 1523

Date 06.02.2022	Payment Period	Transaction#	Card
Amount \$70.00	12 Months	91002265303064	 **** * 1774

PO Box Details

PO BOX LOCATION	PO BOX SIZE	PAYMENT PERIOD	AUTO RENEWAL
PRYOR - Post Office™ 111 S ADAIR ST, PRYOR, OK 74361 (918) 825-6562	 Size 1-XS 3" x 5.5"	12 Months \$70.00	OFF NEXT PAYMENT DUE 06.30.2023



This is an automated email please do not reply to this message. This message is for the designated recipient only and may contain privileged, proprietary, or otherwise private information. If you have received it in error, please delete. Any other use of the email by you is prohibited.

donotreply@usps.com <donotreply@usps.com>
To: katie@pryorchamber.com

Thu, Jun 2, 2022 at 3:43 PM



Hello FREDA ATKINS,

Thank you for your payment to the USPS in the amount of \$160.00 for the PO Box listed below. This payment has been applied to your account and your credit or debit card has been charged.

Transaction number:	91002265306751
Payment amount:	\$160.00
Payment period:	12 months
Payment method:	MASTERCARD credit-card ✓
Next payment due:	06/30/2023
PO Box number:	367
Post Office location:	111 S ADAIR ST PRYOR, OK 74361-9998

Take the stress out of remembering to make your next payment by signing up for our Automatic Renewal payment program. It's free, it's fast, and it's easy! Sign in at usps.com/poboxes and go to the Manage Your Account page. Then, click on Setup Auto Renewal under Next Payment Due. Be sure to review the Terms and Conditions governing automatic payments when you select this option.

Thank you for choosing the United States Postal Service®. We appreciate your business.

Please do not respond to this system-generated email.

If you need assistance with PO Boxes Online, please visit USPS [Help](#) or [Contact Us](#).

[Quoted text hidden]

Payment Successful

Your payment was successful.

Payment Received - PO Box™ 367

Date **06.02.2022**

Payment Period

Transaction#

Card

Amount **\$160.00**

12 Months

91002265306751

 **** * 1774

PO Box Details

PO BOX LOCATION

PRYOR - Post Office™
111 S ADAIR ST, PRYOR,
OK 74361
(918) 825-6562

PO BOX SIZE



Size 3-M
5.5" x 11"

PAYMENT PERIOD

12 Months
\$160.00

AUTO RENEWAL
OFF

NEXT PAYMENT DUE
06.30.2023

PRYOR AREA
CHAMBER OF COMMERCE, INC.

P.O. BOX 367
PRYOR, OK 74362

BUILDING A BETTER COMMUNITY TODAY - FOR TOMMORROW

RCB BANK

P.O. Box 8 Pryor, OK 74362
(918)825-4321 Member FDIC

018910

PAY **** ONE THOUSAND THREE HUNDRED EIGHTY FIVE & 67/100 DOLLARS

TO THE
ORDER OF:

DATE
07/05/22

AMOUNT

\$ **1385.67

VOID AFTER 90 DAYS

Business Card
PO Box 15796
Wilmington, DE 19886

[Handwritten Signature]
AUTHORIZED SIGNATURE



⑈018910⑈ ⑆103112594⑆ 04000121004⑈

PRYOR AREA CHAMBER OF COMMERCE, INC.

018910

Vendor ID: BOFAMERICA

Name: Business Card
Check Date:
Check Amount:

07/05/22
1,385.67

MEMO:

Acct. # 5474976700308445

PRYOR AREA CHAMBER OF COMMERCE, INC.

018910

Vendor ID: BOFAMERICA

Name: Business Card
Check Date:
Check Amount:

07/05/22
1,385.67

MEMO:

Acct. # 5474976700308445

THIS CHECK OR THIS DOCUMENT INCLUDES MICROPRINTED ENDORSEMENT LINE

bacc
PRYOR AREA
CHAMBER OF COMMERCE

Pryor Area Chamber of Commerce
100 E. Graham Ave.
Pryor, OK 74361
918.825.0157
info@pryorchamber.com

NORTHEAST OKLAHOMA
REGIONAL ALLIANCE

Check #	Description	Amount
	2022 Annual Membership	\$ 150.00
TOTAL		\$ 150.00

baac
PRYOR AREA
CHAMBER OF COMMERCE

Pryor Area Chamber of Commerce
100 E. Graham Ave.
Pryor, OK 74361
918.825.0157
info@pryorchamber.com

Print & Digital Advertising & Promotion

Check #	Payee	Description	Amount
18773	PHS Yearbook	1/2 Page Ad	\$ 130.00
18861	Nationwide Hotel Guides	Full Page Ad	\$ 100.00
18909	Arrowhead Outdoor LLC	LED Billboard Advertising (8/1/22 - 7/31/23)	\$ 5,130.00
TOTAL			\$ 5,360.00

Ad Invoice/Statement

~~Pryor High School
1100 SE 9TH ST
PRYOR, OK 74361-7234
(918) 825-2340~~

PHS Yearbook
PO BOX 548
PRYOR, OK 74362

Date: Oct 11, 2021
Order #: Y3710828

To:
Pryor Chamber of Commerce
100 East Graham Ave
Pryor, OK 74361

acct # 125000

Size	Type	Color	Ad Price	Amount Paid	Balance Due	Payment Date
1/2 Page	Business	Color	\$ 130.00	\$ 0.00	\$ 130.00	

PAYMENT SUMMARY

Ad Price: \$ 130.00
Discount: \$ 0.00
Net Amount: \$ 130.00
Payment: \$ 0.00
Balance Due: \$ 130.00

AD SCHEDULE

Photo/Text Due:
Photos/Text Received:

PRYOR AREA
CHAMBER OF COMMERCE, INC.

P.O. BOX 367
PRYOR, OK 74362

BUILDING A BETTER COMMUNITY TODAY - FOR TOMMORROW

018773

RCB BANK

P.O. Box 8 Pryor, OK 74362
(918)825-4321 Member FDIC

PAY **** ONE HUNDRED THIRTY & 0/100 DOLLARS

TO THE
ORDER OF:

DATE

AMOUNT

10/18/21

\$

**130.00

PHS Yearbook
P. O. Box 548
Pyror, OK 74362

VOID AFTER 90 DAYS

Cholke

AUTHORIZED SIGNATURE



⑈018773⑈ ⑆103112594⑆ 04000121004⑈

PRYOR AREA CHAMBER OF COMMERCE, INC.

018773

Vendor ID: PHS YB

Name: PHS Yearbook

Check Date:

10/18/21

Check Amount:

130.00

MEMO:

1/2 Page Ad
Order #Y3710828

PRYOR AREA CHAMBER OF COMMERCE, INC.

018773

Vendor ID: PHS YB

Name: PHS Yearbook

Check Date:

10/18/21

Check Amount:

130.00

MEMO:

1/2 Page Ad
Order #Y3710828

Nationwide Hotel Guides

11110 Edgemont Rd.
Edgemont, AR 72044

Invoice

Date	Invoice #
3/9/2022	109159

Bill To
CHAMBER OF COMMERCE ATTN: BARBARA, DIRECTOR 100 E. GRAHAM AVE. PRYOR, OK 74361

P.O. No.	Terms	Due Date	Rep	Account #	Project
	NET 45	4/25/2022			

Description	Amount
FULL-PAGE COLOR ADVERTISEMENT IN GUEST ROOM DIRECTORIES FOR ONE YEAR AT THE FOLLOWING PROPERTIES: PRYOR HOTELS IN PRYOR, OKLAHOMA	100.00
<p>acct # 125000</p>	
Total	\$100.00

Phone #	Fax #	E-mail
501-723-8338	501-723-8182	ntgihotelguides2017@gmail.com

PRYOR AREA
CHAMBER OF COMMERCE, INC.

P.O. BOX 367
PRYOR, OK 74362

BUILDING A BETTER COMMUNITY TODAY - FOR TOMMORROW

RCB BANK

P.O. Box 8 Pryor, OK 74362
(918)825-4321 Member FDIC

018861

AY **** ONE HUNDRED & 0/100 DOLLARS

TO THE
ORDER OF:

DATE AMOUNT
04/08/22 \$ **100.00

Nationwide Hotel Guides
11110 Edgemond Rd.
Edgemont, AR 72044

VOID AFTER 90 DAYS

Cholke
AUTHORIZED SIGNATURE



⑈018861⑈ ⑆103112594⑆ 04000121004⑈

PRYOR AREA CHAMBER OF COMMERCE, INC.

018861

Vendor ID: NATHOTGU

Name: Nationwide Hotel Guides
Check Date: 04/08/22
Check Amount: 100.00

MEMO:
Invoice #109159

PRYOR AREA CHAMBER OF COMMERCE, INC.

018861

Vendor ID: NATHOTGU

Name: Nationwide Hotel Guides
Check Date: 04/08/22
Check Amount: 100.00

MEMO:
Invoice #109159

Arrowhead Outdoor LLC

PO Box 1381
 Pittsburg, KS 66762

INVOICE

Invoice Number: 14624
 Invoice Date: Jun 30, 2022
 Page: 1

Voice: 620-778-3010
 Fax:

Bill To:
Pryor Chamber of Commerce 100 E Graham Ave Pryor, OK 74361

Ship to:
Pryor Chamber of Commerce 100 E Graham Ave Pryor, OK 74361

Customer ID	Customer PO	Payment Terms	
Pryor Chamber of Com		Net 10 Days	
Sales Rep ID	Shipping Method	Ship Date	Due Date
Mike McCollough			7/10/22

Quantity	Item	Description	Unit Price	Amount
		08/01/2022 - 07/31/2023		
12.00	Pryor, OK Board	LED Billboard Ad - Pryor, OK	450.00	5,400.00
12.00	Pryor, OK Board	5% discount for up front payment	22.50	-270.00

Subtotal	5,130.00
Sales Tax	
Total Invoice Amount	5,130.00
Payment/Credit Applied	
TOTAL	5,130.00

Check/Credit Memo No:

PRYOR AREA
CHAMBER OF COMMERCE, INC.

P.O. BOX 367
PRYOR, OK 74362

BUILDING A BETTER COMMUNITY TODAY - FOR TOMMORROW

RCB BANK

P.O. Box 8 Pryor, OK 74362
(918)825-4321 Member FDIC

018909

PAY **** FIVE THOUSAND ONE HUNDRED THIRTY & 0/100 DOLLARS

DATE

AMOUNT

06/30/22

\$

**5130.00

VOID AFTER 90 DAYS

[Handwritten Signature]
AUTHORIZED SIGNATURE



TO THE
ORDER OF:

Arrowhead Outdoor LLC
PO Box 1381
Pittsburg, KS 66762

⑈018909⑈ ⑆103112594⑆ 04000121004⑈

PRYOR AREA CHAMBER OF COMMERCE, INC.

018909

Vendor ID: ARROWHEAD

Name: Arrowhead Outdoor LLC

Check Date: 06/30/22

Check Amount: 5,130.00

MEMO:

Inv # 14624

PRYOR AREA CHAMBER OF COMMERCE, INC.

018909

Vendor ID: ARROWHEAD

Name: Arrowhead Outdoor LLC

Check Date: 06/30/22

Check Amount: 5,130.00

MEMO:

Inv # 14624

baac
PRYOR AREA
CHAMBER OF COMMERCE

Pryor Area Chamber of Commerce
100 E. Graham Ave.
Pryor, OK 74361
918.825.0157
info@pryorchamber.com

SPONSORSHIPS

Description	Amount
2022 Pryor Creek Music Festivals T-Shirt Sponsor	\$ 3,000.00
2022 DAM J.A.M. T-Shirt Sponsor	\$ 1,500.00
TOTAL	\$ 4,500.00

pace
PRYOR AREA
 CHAMBER OF COMMERCE

Invoice
 27637

Pryor Area Chamber of Commerce
 PO Box 367
 100 E Graham Ave
 Pryor, OK 74362

Invoicing Date: 06/23/2022
Member ID: 277
Invoice Due: 06/23/2022

Larry Lees
 City of Pryor
 PO Box 1167
 Pryor, OK 74362

Description	Qty	Rate	Amount
2022 Rocklahoma and Born & Raised Volunteer T-Shirt Sponsor In-Kind Sponsorship	2.00	1,500.00	3,000.00 -3,000.00

We sincerely appreciate your support of our community and the Pryor Area Chamber of Commerce.

Total:	0.00
Amt Paid:	0.00
Balance Due:	0.00

✂

Member ID	Invoice	Due Date	Total Due	Total Payment Enclosed
277	27637	06/23/2022	\$0.00	\$

Please verify address and provide corrections

Larry Lees
 City of Pryor
 PO Box 1167
 Pryor, OK 74362

Correct Address

Make checks payable to:

Pryor Area Chamber of Commerce
 PO Box 367
 100 E Graham Ave
 Pryor, OK 74362

MasterCard

Visa

Card No.

Exp. Date

Signature

Sec. Code

Convenient online payment option at: <http://www.pryorchamber.com>



Invoice
27638

Invoicing Date: 06/23/2022
Member ID: 277
Invoice Due: 06/23/2022

Pryor Area Chamber of Commerce
PO Box 367
100 E Graham Ave
Pryor, OK 74362

Larry Lees
City of Pryor
PO Box 1167
Pryor, OK 74362

Description	Qty	Rate	Amount
2022 DAM J.A.M. T-Shirt Sponsor	1.00	1,500.00	1,500.00
In-Kind Sponsorship			-1,500.00

We sincerely appreciate your support of our community and the Pryor Area Chamber of Commerce.

Total:	0.00
Amt Paid:	0.00
Balance Due:	0.00

Member ID	Invoice	Due Date	Total Due	Total Payment Enclosed
277	27638	06/23/2022	\$0.00	\$

Please verify address and provide corrections

Larry Lees
City of Pryor
PO Box 1167
Pryor, OK 74362

Correct Address

Make checks payable to:

Pryor Area Chamber of Commerce
PO Box 367
100 E Graham Ave
Pryor, OK 74362

MasterCard

Visa

Card No.

Exp. Date

Signature

Sec. Code

Convenient online payment option at: <http://www.pryorchamber.com>

M&M Properties, LLC
22 South Adair Street
Pryor, OK 74361
(918) 630-1231
montylittlefield@gmail.co
m



ADDRESS

City of Pryor Creek
24 South Rowe Street
Pryor, Oklahoma 74361

ESTIMATE # 1460
DATE 08/16/2022

P.O. NUMBER

Chamber of Commerce

Scope of Work	Construct wall on top of current short wall, 2x4 frame at 16-inch center, insulation R-13 batt, sheetrock, compound joint tape with orange peel finish texture, wall paint primer and 2 coats 1 color, add solid core 6 panel door, door hardware satin nickel, door and trim paint with pro-classic extra white.	9,889.65
----------------------	---	----------

This estimate is a rough bid and all prices are subject to change in accordance to product and labor pricing. The above fee is based on information provided and the assumption that unexpected circumstances will not be encountered during the project. If significant additional labor or material is necessary, we will discuss it with you and arrive at a new fee estimate before incurring additional costs. Unless otherwise stated, payment is due upon presentation of the invoice. At a minimum, billing will be performed at the completion of each scope of work. Balances 30 days past due will accrue a monthly 6% late fee.

TOTAL

\$9,889.65

Accepted By

Accepted Date

**CITY OF PRYOR CREEK
HOTEL/MOTEL FUND**

P.O. BOX 1167
PRYOR CREEK, OKLAHOMA 74362

RCB BANK
CLAREMORE - PRYOR - OWASSO
COLLINSVILLE - INOLA
SKIATOOK - BROKEN ARROW
86-1259-1031

VOID AFTER 60 DAYS

FISCAL YEAR
.021-2022

ENCUMBRANCE NO.

DATE
9/21/2021

WARRANT NO.
285

AMOUNT
45,270.35

Forty-Five Thousand Two Hundred Seventy and 35/100 Dollars

BY ORDER OF THE GOVERNING BOARD:

CHAMBER OF COMMERCE

[Signature]
MAYOR

PAY
TO THE
ORDER
OF

100 E GRAHAM
PO BOX 367
PRYOR CREEK OK 74362

Eva Smith
CLERK

Lou Thompson
TREASURER

⑈000285⑈ ⑆103112594⑆ 00000103416⑈

CITY OF PRYOR CREEK HOTEL/MOTEL FUND

285

VENDOR: 2156 CHAMBER OF COMMERCE

9/21/2021

Check No: 285

INVOICE #	PO #	INV DATE	DESCRIPTION	INV AMOUNT
2020 CHRISTMAS P	2020201190	9/21/2021	HOTEL/MOTEL - PARADE OF LIGHTS - 202	1,532.95
2021/2022 40%	2120210699	9/21/2021	HOTEL/MOTEL - 2021 - 2022 FY - 40% ALL	43,737.40

TOTAL AMOUNT 45,270.35

CITY OF PRYOR CREEK
 BALANCE SHEET
 JUNE 30, 2022

HOTEL MOTEL TAX REVENUE ACCOUN

<u>ASSETS</u>			
75-000-1025	RCB - GENERAL CHECKING		124,248.79
	TOTAL ASSETS		<u>124,248.79</u>
<u>LIABILITIES AND EQUITY</u>			
<u>LIABILITIES</u>			
75-000-2005	ENCUMBRANCES PAYABLE	(2,500.00)	
	TOTAL LIABILITIES		(2,500.00)
<u>FUND EQUITY</u>			
75-000-3010	FUND BALANCE		109,343.51
	UNAPPROPRIATED FUND BALANCE: REVENUE OVER EXPENDITURES - YTD	<u>17,405.28</u>	
	BALANCE - CURRENT DATE		<u>17,405.28</u>
	TOTAL FUND EQUITY		<u>126,748.79</u>
	TOTAL LIABILITIES AND EQUITY		<u>124,248.79</u>

HOTEL / MOTEL TAX ALLOCATION BUDGET 2022 - 2023

BUDGET								
Recipient	Budget	Approval Dates	Actual Expenditures	Total Unapproved Expenditures (Will be taken off next cycle)	Purchase Order #	Ck#	Date Paid	Follow up Date
Pryor Area Chamber of Commerce (40%)	\$49,699.52	H/M Board:						
		Budget Com:						
		City Council:						
Pryor Public Schools (20%)	\$24,849.76	H/M Board:						
		Budget Com:						
		City Council:						
Pryor High School Band Day (Minimum \$2,500.00 from PPS Total)	\$0.00	H/M Board:						
		Budget Com:						
		City Council:						
Pryor Main Street (10%)	\$12,424.88	H/M Board:						
		Budget Com:						
		City Council:						
Grant Applications (20%)	\$24,849.75	H/M Board:						
		Budget Com:						
		City Council:						
Reserve (10%)	\$12,424.88	H/M Board:						
		Budget Com:						
		City Council:						
Grand Total	\$124,248.79		-					

HOTEL / MOTEL TAX GRANTS 2022 - 2023		Budget = \$24,849.75			Reserve = \$12,424.88			
RECIPIENT	AMT AWARDED	TO BE USED FOR	Receipts Received Total Amt of Receipts	Receipts Approved by CC	Purchase Order #	Ck#	Date Paid	Follow up Date
LAKE AREA SOFTBALL ASSOCIATION	H/M:			H/M Board:				
	Budget Com:			Budget Com:				
	City Council:			City Council:				
Amt requested:	\$5,000.00	Date Paid	ACCOUNT #					
	H/M:			H/M Board:				
	Budget Com:			Budget Com:				
	City Council:			City Council:				
Amt requested:		Date Paid	ACCOUNT #					
	H/M Board: \$			H/M Board:				
	Budget Com:			Budget Com:				
	City Council:			City Council:				
Amt requested:		Date Paid	ACCOUNT #					
	H/M Board:			H/M Board:				
	Budget Com:			Budget Com:				
	City Council:			City Council:				
Amt requested:		Date Paid	ACCOUNT #					
	H/M Board:			H/M Board:				
	Budget Com:			Budget Com:				
	City Council:			City Council:				
Amt requested:		Date Paid	ACCOUNT #					
	H/M Board:			H/M Board:				
	Budget Com:			Budget Com:				
	City Council:			City Council:				
Amt requested:		Date Paid	ACCOUNT #					
	H/M Board:			H/M Board:				
	Budget Com:			Budget Com:				
	City Council:			City Council:				
Amt requested:		Date Paid	ACCOUNT #					
	H/M Board:			H/M Board:				
	Budget Com:			Budget Com:				
	City Council:			City Council:				
Amt requested:		Date Paid	ACCOUNT #					
AMT REQUESTED	BUDGET	AMT AWARDED						
\$5,000.00	\$24,849.75							
Reserve (10%)	12,424.88							
TOTAL	\$37,274.63							
						Funding available	\$24,849.75	

HOTEL / MOTEL TAX ALLOCATION GRANT PROJECT APPLICATION



To be considered for the City of Pryor Creek Hotel / Motel Tax Allocation Grant, please complete the form below.

Street address:

Street address line 2:

City:

State:

Zip code:

Contact Person

First name:

Last name:

Phone number:

E-mail:

Is your organization a non-profit or public tax-exempt organization as defined under Section 501(c)(3) of the Internal Revenue Code?

Yes

No

Requested amount:

Applicant's Match amount:

Total Project Budget:

Description of event or project summary:

Provide a paragraph, a concise summary of your request and what it will accomplish. If your request is part of a larger project, you may briefly describe the over all project. However, please focus the bulk of your answer on the specific element for which you are requesting funding.

Where and when will the event take place?

Resources available for project / event:

PROJECT BUDGET

Please detail the budget for your project. Specify whether your various match items will be cash or in-kind.

Pro-Forma

Project Title:

Revenues:

Total Requested from Hotel / Motel:

Total Project Revenues:

Expenses:

Advertising

Promotional Printing

Miscellaneous expenses:

Total Expenses:

565795

MIBB CONSTRUCTION, INC

2633 S 426

PRYOR, OK 74361

Ph (918) 373-3413

CUSTOMER'S ORDER NO. DEPARTMENT DATE 7-25-22

NAME Pryor Softball

ADDRESS
CITY, STATE, ZIP

SOLD BY	CASH	C.O.D.	CHARGE	ON ACCT.	MDSE. RETD.	PAID OUT
---------	------	--------	--------	----------	-------------	----------

QUANTITY	DESCRIPTION	PRICE	AMOUNT
----------	-------------	-------	--------

6	metal framing + sheeting of bleacher shades	2500 each	15000
---	---	-----------	-------

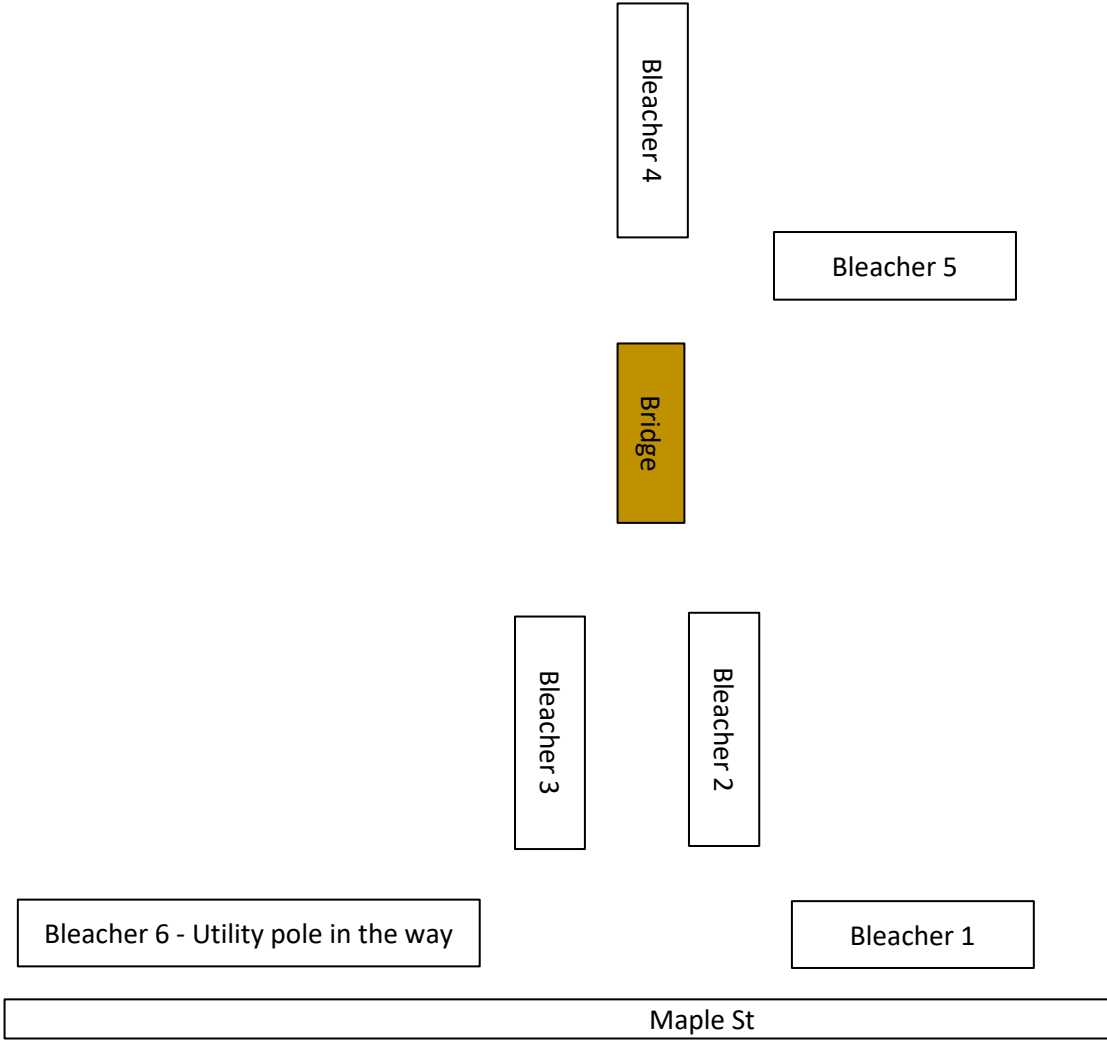

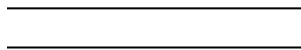

PLAY-BY-DESIGN

ESTIMATE



2929 E 56th Pl
 Tulsa, Ok 74105
 918-640-5348

LizM.PBD@gmail.com

Date
 7/29/2022

PROJECT GREEN COUNTRY SOFTBALL FIELDS
 ATTN: CAMBRA
 300 S. Maple St
 PRYOR, OK 74361

SHIPPING METHOD	SHIPPING TERMS	DELIVERY DATE
best way		

QTY	ITEM #	DESCRIPTION	UNIT PRICE	LINE TOTAL
1.00	Bleacher 1	Hanging cantilever shade - 24'x10'x12'		\$7,252.00
		INSTALL		\$8,750.00
		FREIGHT TO JOBSITE		\$1,557.00
2.00	Bleacher 2/3	Hanging cantilever shade - 24'x10'x10'	\$6,980.00	\$13,960.00
		INSTALL	\$8,750.00	\$17,500.00
		FREIGHT TO JOBSITE		\$2,998.00
2.00	Bleacher 4/5	Hanging cantilever shade - 23'x10'x12'	\$7,205.00	\$14,410.00
		INSTALL	\$8,750.00	\$17,500.00
		FREIGHT TO JOBSITE		\$3,092.00

SUBTOTAL	\$87,019.00
TAX	
TOTAL	\$87,019.00

¹
 ESTIMATE GOOD UNTIL AUGUST 31, 2022

 Date



TRUST == *the* == EXPERTS

For over a decade, our customers have entrusted us to provide safe and affordable playground and recreational equipment. Our team of Certified General Contractors and Playground Safety Inspectors will insure that your project is completed to perfection, providing truly turnkey service, with every step of the process from planning and budgeting, through the installation being handled under one roof.



1-800-573-7529 | www.proplaygrounds.com



Pro Playgrounds
8490 Cabin Hill Road
Tallahassee, FL 32311

Quote

Project Name
Jeff Shade Job



Date	Estimate #
7/19/2022	16079

Customer / Bill To
Green Country Softball Fields 112 S. Maple St Pryor, OK 74361

Ship To
112 S. Maple St Pryor, OK 74361



WE WILL BEAT ANY PRICE BY 5%!

Item	Description	Qty	Cost	Total:
22-TC301210SG	supply and install 6x spectator shades, T-cantilevers 30x12x11			
	4Rx27L-T-Cantilever 30 x 12 x 10 surface mount w/ glide	6	7,999.00	47,994.00
ENGDRAW	Engineered Drawings for Permitting	1	1,080.00	1,080.00
Shipping	Combined Shipping and Freight Charges		1,800.00	1,800.00
CLR	Colors: frame and fabric colors TBD			0.00
	Installation, Labor and raw materials approx 30-35K for a project like this. Local contractor will need to permit, could install and save some dollars if associated with your organization.			

AGREED AND ACCEPTED:
If the above total price, scope of work, specifications, terms and conditions are acceptable, sign below indicating your acceptance and authorization for Pro Playgrounds to proceed with the work and/or sales transaction described in this quotation. Upon signature and payment in accordance with this quote, Pro Playgrounds will proceed with the work and/or sales transaction.

_____/_____/_____
Signature Name / Title Date

Subtotal:	\$50,874.00
Sales Tax: (7.5%)	\$0.00
Total:	<u>\$50,874.00</u>

Terms and Conditions - Price valid for 30 days and subject to change. 1. If installation is not included with your purchase, client will be responsible for coordinating, receiving and unloading of all goods, delivery drivers will not help unload goods. 2. Client will be responsible to inspect goods for defect, damage or missing parts, any deficiency or missing parts must be noted on delivery slip. 3. Client will be responsible for costs due to cancelled or missed delivery appointments. 4. Client has reviewed all items, colors and descriptions on this quote for accuracy and correctness. 5. If quote includes installation of goods, the installation is subject to the terms and conditions of Pro Playgrounds "Standard Installation Agreement" a copy of which may be obtained from your Sales Representative.

Tee Cantilever Hip Shade

Length	30	Width	12	Entry Height	10
Peak Height	12.42	Elbow	Standard	Column Mount	Base Plate
Column Size	6060.25	Rafter Size	3.511	Ridge Size	3.511
Column Length	10.5	Rafter Length	8.53101548	Ridge Length	18.8810809

Dome Qty: 1 Column Qty: 2

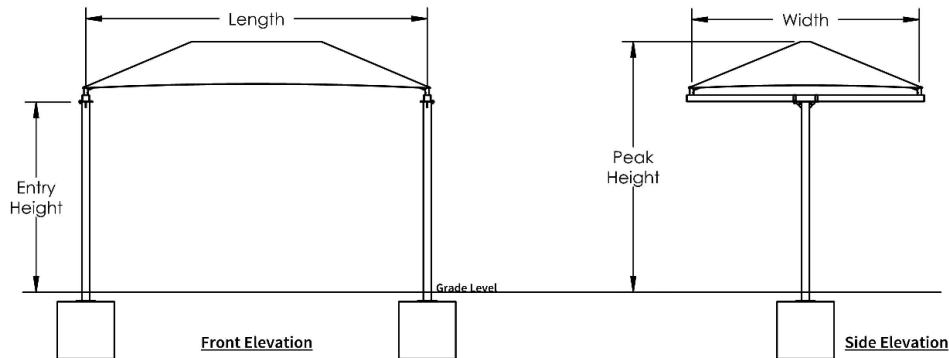
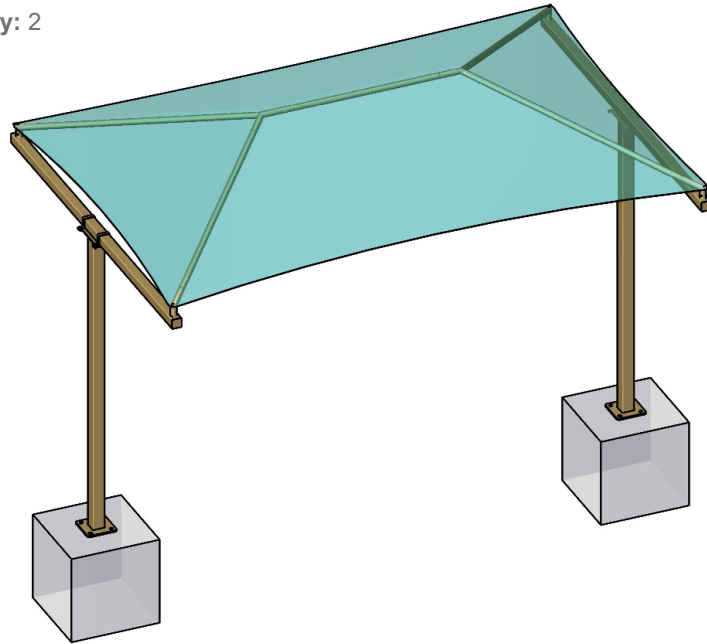

Square Footing		
Column	Length & Width	Depth
Single Cap	3.52	3
Double Cap	N/A	3

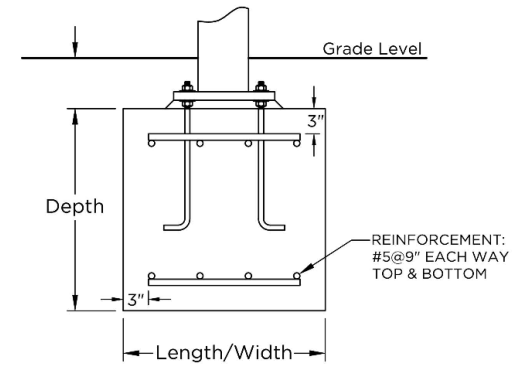

Auger Footing		
Diameter	Single Cap Depth	Double Cap Depth
1'-6"		
2'-0"	Out of range	N/A
2'-6"	Out of range	N/A
3'-0"	4.2	N/A

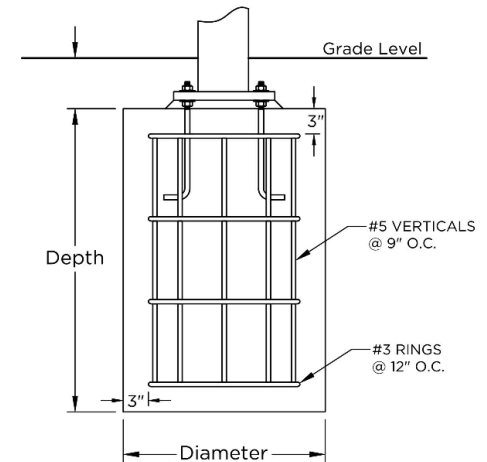

SHADE
BY SUPERIOR RECREATIONAL PRODUCTS

QUOTE

SHADE SIZE
30 X 12

SHADE STYLE
**Tee Cantilever
Hip Shade**

These drawings are for reference only and should not be used as construction details. They show the general character and rough dimensions of the structural features. Exact spans, fasteners, materials, and foundations can be determined by a licensed professional engineer upon request. Estimated footing size above is based on 1,500 PSF soil bearing pressure.





Untitled Map
Write a description for your map.

Legend
Green Country Softball Fields



Traditional Shade Fabric Colors



*Not California Fire Marshal certified

Frame Color Options



*Semi-gloss finish.

SHADE

BY SUPERIOR RECREATIONAL PRODUCTS

Shade Structure Material Specifications

FABRIC SPECIFICATIONS

- Shade fabric is made of UV stabilized cloth manufactured by ALNET or approved equal.
- The high density polyethylene material shall be manufactured with tensioned fabric structures in mind.
- The fabric knit is to be made using monofilament and tape filler which has a weight of 9.38 to 10.32 oz. sq. yd. Material to be Rachel-knitted to ensure material will not unravel if cut.
- Burst strength of 828 lbf (ASTM 3786).
- Cloth meets fire resistance tests as follows:

Alnet Extra Block: California State Fire Marshall Reg. #F-93501

Others: NFPA 701-99 (Test Method 2) and ASTM E-84

FABRIC PROPERTIES

STRETCH	STENTORED
Tear Tests (lbs/ft)	WARP 44.8 WEFT 44
Burst Tests (lbs ft)	828
Fabric Weight (oz/sqFT)	avg 1.02 to 1.07
Fabric Width	9'-10"
Roll Length	150'
Roll Size	63" x 16.5"
Weight	120 lbs.
Life Expectancy	10 years
Fading	Minimum fading after 6 years, 3 years for red and yellow
Temperature	-77 degrees
Maximum Temperature	+167 degrees

Continued on Page 2

- Shade protection and UV screen protection factors are as follows:

SHADE PROTECTION AND UV BLOCK OUT

Color	Shade Cover	UVR Block Out
True Blue	93%	89%
Beige	97%	87%
Forest Green	96%	94%
Sun Blaze	94%	91%
Silver	95%	93%
Black	98%	97%
River Gum Green	95%	92%
Sky Blue	95%	94%
Navy Blue	96%	95%
Turquoise	94%	94%
Yellow	76%	94%
Cream	74%	92%

THREAD

- Shall be 100% expanded PTFE fiber which carries a 10 year warranty that is high strength and low shrinkage.
- Shall have a wide temperature and humidity range.
- Abrasion resistant and UV radiation immunity.
- Shall be unaffected by non-hydrocarbon based cleaning agents, acid rain, mildew, chlorine, saltwater, and pollution.
- Lockstitch thread - 1200 Denier or equal.
- Chain stitch thread - 2400 Denier or equal.

STEEL TUBING

- All fabricated steel must be in accordance with approved shop drawings and calculations.
- All steel is cleaned, degreased or etched to ensure proper adhesion of Superdurable powder coat in accordance with manufacturer’s specifications.
- All Steel used on this project needs to be new and accompanied by the mill certificates if requested. Structural steel tubing up to 5”-7 gauge shall be galvanized per Allied Steel FLO-COAT specifications. Schedule 40 black pipe fabrications shall be sand-blasted and primed as described below.
- All non-hollow structural shapes comply with ASTM A-36, unless otherwise noted.
- All hollow structural steel shapes shall be cold formed HSS ASTM A-53 grade C, unless otherwise noted.
- Plate products shall comply with ASTM A-36.

SUPERDURABLE POWDER COATING & PRIMING

- All non-galvanized steel shade to be sand-blasted and primed prior to Superdurable powder coating using reclaimable blast media in a mixture of GL50 & GL80 Steel Grit.
- All non-galvanized steel must be coated with rust inhibiting primer prior to applying the Superdurable powder coat. Primer shall be Marine Grade Cardinal Industrial Finishes Corp. E396-GR1372 epoxy Superdurable powder coating semi-gloss smooth zinc rich primer.

- Welds shall be primed with rust inhibiting primer prior to applying the Superdurable powder coat. Primer shall be Marine Grade Cardinal Industrial Finishes Corp E396-GR1372 epoxy Superdurable powder coating semi-gloss smooth zinc rich primer.
- All steel parts shall be coated for rust protection and finished with a minimum 3.5 mil thick UV-inhibited weather resistant Superdurable powder coating.
- Powder used in the Superdurable powder coat process shall have the following characteristics:

CHARACTERISTICS

N.3.1	Specific Gravity	1.68+/-0.05
N.3.2	Theoretical Coverage	114+/- 4 ft 2/lb/mil
N.3.3	Mass Loss During Cure	<1%
N.3.4	Maximum Storage Temperature	75° F

- Superdurable powder coating shall meet the following tests:

TESTS

ASTM	Gloss at 60 Degree	85-95
HOI TM 10.219	PCI Powder Smoothness	7
ASTM D2454-91	Over-Bake Resistance Time	200%
ASTM D3363-92A	Pencil Hardness	H-2H
ASTM D2794-93	Dir/Rev Impact, Gardner	140/140 in/lbs
ASTM D3359-95B	Adhesion, Cross Hatch	5B Pass
ASTM D522-93A	Flexibility Mandrel	¼" dia. No fracture
ASTM B117-95	Salt Spray	1,000 hours
UL DtoV2	Organic Coating Steel Enclosures, Elect Eq.	Recognized

- Application criteria:

APPLICATION CRITERIA

N.5.1	Electrostatic Spray Cold	Substrate:0.032 in. CRS
N.5.2	Cure Schedule	10 minutes at 400° F
N.5.3	Pretreatment	Bonderite 1000
N.5.4	Film Thickness	3.5 Mils

WELDING

- All shop welds shall be executed in accordance with the latest edition of the American Welding Society Specifications.
- Welding procedures shall comply in accordance with the AWS D1.1-AWS Structural Welding Code-Steel.
- All welds to be performed by a certified welder. All welds shall be continuous where length is not given, unless otherwise shown or noted on drawings.
- All welds shall develop the full strength of the weaker member. All welds shall be made using E70xx.035 wire.
- Shop connections shall be welded unless noted otherwise. Field connections shall be indicated on the drawings. Field welded connections are not acceptable.
- All fillet welds shall be a minimum of ¼" unless otherwise noted.
- All steel shall be welded shut at terminations to prevent internal leakage.

- Internal weld sleeving is not acceptable.
- On-site welding of any component is not acceptable.

SEWING

- On-site sewing of a fabric will not be accepted.
- All corners shall be reinforced with extra non-tear cloth and strap to distribute the load.
- The perimeters that contain the cables shall be double lock stitched.

INSTALLATION HARDWARE

- Bolt and fastening hardware shall be determined based on calculated engineering loads.
- All bolts shall comply with SAE-J429 (Grade 8) or ASTM A325 (Grade BD). All nuts shall comply with ASTM F-594, alloy Group 1 or 2.
- Upon request, Stainless Steel hardware shall comply with ASTM A-304.
- 1/4" galvanized wire rope shall be 7x19 strand with a breaking strength of 7,000 lbs. for shades generally under 575 sq. ft. unless requested larger by the customer. For shades over 575 sq. ft., cable shall be 5/16" with a breaking strength of 9,800 lbs. Upon request, 1/4" Stainless Steel wire rope shall be 7x19 strand with a breaking strength of 6,400 lbs. 5/16" Stainless Steel wire rope shall be 7/19 strand with a breaking strength of 9,000 lbs.
- All fittings required for proper securing of the cable are hot dipped galvanized.

CONCRETE

- Concrete work shall be executed in accordance with the latest edition of American Concrete Building Code ACI 318 unless specified by the governing municipality.
- Concrete specifications shall comply in accordance with, and detailed as per plans as follows:
 1. 28 Days Strength F'c = 2500 psi
 2. Aggregate: HR
 3. Slump: 3-5
 4. Portland Cement shall conform to C-150
 5. Aggregate shall conform to ASTM C-33
- All reinforcement shall conform to ASTM A-615 grade 60.
- Reinforcing steel shall be detailed, fabricated and placed in accordance with the latest ACI Detailing Manual and manual of Standard Practice.
- Whenever daily ambient temperatures are below 80° Fahrenheit, the contractor may have mix accelerators and hot water added at the batch plant (see table).

- The contractor shall not pour any concrete when daily ambient temperature is below 55° Fahrenheit.

TEMPERATE

Temperature Range	% Accelerator	Type Accelerator
75-80°	1%	High Early (non calcium)
70-75°	2%	High Early (non calcium)
Below 70°	3%	High Early (non calcium)

FOOTINGS

- All anchor bolts set in new concrete shall be ASTM A-307, or ASTM F-1554 if specified by engineer.
- All anchor bolts shall be zinc plated unless specified otherwise.
- Footing shall be placed in accordance with and conform to engineered specifications and drawings.

Shade Warranty

GENERAL CONDITIONS

The warranty set forth shall be the purchaser's sole and exclusive warranty. All warranties below are effective from the date of delivery by Superior Shade, its subsidiaries, or agents. Superior Shade reserves the right to repair or replace any item covered by this warranty.

- This warranty will be void if the structures are not paid for in full. The warranty is void if the structures are not installed in strict compliance with the manufacturer specifications.
- Purchaser shall notify Superior Shade or its agent in writing detailing any defect for which a warranty claim is being made.
- Superior Shade shall not in any event be liable for indirect, special, consequential or liquidated damages.
- Superior Shade specifically denies the implied warranties of fitness for a particular purpose and merchantability.
- The warranty is void if any changes, modifications, additions or attachments are made to the structures or fabric without the written consent of the manufacturer.
- No signs, objects, ornaments, fans, lights, fixtures or decorations may be hung from the top part of the structure, unless specifically designed and engineered by the manufacturer. These items may interfere with the fabric causing the warranty to be voided.
- 1 year limited warranty on all moving parts and any item not specifically listed above.

THREAD

Thread shall be 100% expanded PTFE fiber that is high strength and low shrinkage, which carries a 10 year warranty. This warranties that the sewing thread will be free from defects in material and workmanship and will not be damaged by exposure to sunlight, weather and water. All other warranties disclaimed.

FABRIC

Superior Shade fabrics carry a ten-year limited manufacturer's warranty from the date of delivery against failure from significant fading*, deterioration, breakdown, outdoor heat, cold, or discoloration. Should the fabric need to be replaced under the warranty, Superior Shade will manufacture and ship a new fabric at no charge for the first six years, thereafter pro-rated at 18% per annum over the last four years.

**The colors Red and Yellow are warranted against significant fading for only two years.*

If the corners of the fabric are equipped with both holes in the fabric corner PLUS reinforcing straps, BOTH the strap and fabric hole must be placed over each corner hook or the fabric warranty is void.

Fabric curtains, valences or flat vertical panels are not covered under the warranty.

Fabric is not warranted where it is installed on a structure that is not engineered and built by Superior Shade or its agents.

This warranty shall be void if damage to or failure to the shade structure is caused by contact with chemicals, chlorine, bleaching agents, hydrocarbons or hydrocarbon containing solvents, misuse, vandalism or any act of God, including but not limited to wind in excess of the wind limitations set forth below.

All fabric tops are warranted for sustained winds up to 76mph (hurricane force 1) and for gusts of up to 3 seconds duration up to 90mph. Removal of the shade fabric is required if damaging winds are called for. Damage due to snow and/or ice accumulation is not covered by this warranty. Canopies should be removed during the "off season".

These structures have been designed to eliminate any friction between the rafters and the fabric. The warranty will, therefore, be voided if any modification (temporary or permanent) is made to the rafter, cross pieces or ridge beams, or if the fastening apparatus is not secured accordingly.

Superior Shade reserves the right, in cases where certain fabric colors have been discontinued, to offer the customer a choice of available colors to replace the warranted fabric of the discontinued color. The company does not warrant that any particular color will be available for any period of time and reserves the right to discontinue any color for any reason it may determine, without recourse by the owner of the discontinued fabric color.

STEEL STRUCTURE

The structural steel frames are covered for a period of twenty years against failure due to rust-through corrosion under normal environmental conditions. Workmanship is warranted for a period of five years.

Structures are warranted for winds up to 90 mph only if shade canopies have been removed as per requirement set forth above in the fabric paragraph. Removal and re-installation must be performed by a qualified person or authorized dealer following the instructions in APPENDIX A below.

This steel warranty shall be void if damage to the steel frame is caused by the installer or from physical damage, damage by salt spray or sprinkler systems, contact with chemicals, chlorine, pollution, misuse, vandalism, or any act of God.

SUPERDURABLE POWDER COAT FINISH

The limited warranty for powder coating provides for the following after a five year exposure period when applied according to the recommendations listed on the product's technical data sheet and appropriate surface preparation has been utilized.

- The coatings shall retain their original color with a ΔE of < 7.5 units for high chroma colors, (Yellows, Reds, Oranges, Etc.) and a ΔE of < 5.0 units for low chroma colors, when tested in accordance with ASTM D 2244.
- The coating shall retain a minimum of 50% of its original gloss level after washing, when tested in accordance with ASTM D 523.
- The coating shall exhibit chalking no worse than a numerical rating of 6, when evaluated in accordance with ASTM D 659-80.

ACTS OF NATURE

This warranty does not cover natural disasters, such as earthquakes, shifts of terrain, or tornadoes. If the structure is installed in an area exposed to hurricanes, removal of the shade fabric is required when a hurricane warning is issued.

Appendix A: Proper Care, Maintenance, and Safe Removal of the Shade Canopy

AVOID

SNOW, ICE, AND HIGH WINDS: Remove the canopy in winter conditions as ice and snow loads are not covered by the warranty. The same goes for winds in excess of hurricane force 1.

SHARP OBJECTS: Always avoid dragging the fabric across surfaces, etc. Roll or fold the fabric and carry it. Avoid sharp objects, bolts, snags, and other protrusions including mounting hardware.

OBSTRUCTIONS: Keep foliage, such as tree limbs, shrubbery, and bushes, trimmed back and away from fabric at least three to four feet.

SOURCES OF HEAT: Avoid contact with heat sources such as hot lights, torches, and avoid using grills, etc. under the fabric.

CLEANING THE FABRIC

The fabric itself is generally maintenance free with the exception of necessary removal due to weather or seasonal requirements. The fabric does not harbor mildew or mold, but residues such as tree sap, leaves, bird droppings, dust and dirt may need to be

removed. To clean the fabric, use water and mild soap. A soft mop or soft broom may also be used. Cleaners that do not contain hydrocarbons, solvents, bleach or ammonia may be used. Use of solvents, hydrocarbons, bleach, and ammonia type cleaners will void the fabric warranty. A pressure washer may be used if necessary using a wide-spray nozzle.

CABLES AND HARDWARE

It is recommended that the cables be replaced every 3 to 4 years or if corrosion is visible, whichever comes first. The cable ends must be wrapped with tape to secure any wires; thus, preventing the wires from tearing the fabric. Taping must be done when removing old cable as well as when installing new cable. Clamps should be replaced when the cable is replaced. If the cable appears slack on a still day (no wind), immediately have the cable and clamps re-tightened by a qualified person. The cable should not be slack.

GLIDE ELBOW™

Lubricate Glide Elbows™ annually and before operating. A waterproof grease is recommended such as a lithium-based grease or anti-seize thread lubricant.

STORAGE

Fabric must be stored in a clean, dry place free from snags, sharp edges, etcetera. The storage area must be rodent-free. Wrap all hardware fittings with rags or some other protector, as they can damage the fabric.

UNINSTALLING THE SHADE CANOPY

NECESSARY CARE: It is important to take necessary care when handling the fabric during removal and installation to prevent damage to the fabric as well as SAFE control of the fabric in a breeze or wind. The fabric is tough and engineered for use as a shade, but it can tear or cut when or if pulled over a snag or sharp item; it can puncture from bolts or other protruding objects; and it can melt from objects such as like cigarettes, matches, hot torch tips, sparks and the like. In addition, care must be exercised to avoid the fabric hooks after the fabric is unhooked from the elbow corners and sides of the structure where there are intermediate supports. It is best to wrap any connected mounting hardware to prevent it from harming the fabric.

PROPER AND SAFE: Based on the size of the canopy, several persons may be needed to properly and safely handle the fabric during the uninstalling process. You will need several commercial ladders or other means to work safely at heights such as scissor lifts, etc. It is advised that you pad the post side of the ladder and tie the ladder to the post. The pad is to protect the post finish. Also keep in mind that every 100 square feet of fabric (10' X 10') weighs approximately five pounds; a large canopy can get heavy fast. For proper control of the fabric, read below. It is best to remove the fabric on a still day. Do not attempt to remove the canopy in strong or gusty winds.

REMOVAL OF THE CANOPY: Do not attempt to remove the canopy in strong or gusty winds.

STANDARD ELBOWS: For shade structures with Standard Elbows, loosen the turnbuckle several turns in order to put enough slack in the cable to allow the fabric and cable to unhook from all the elbow hooks. Attach 3/8" or larger ropes to each corner of the fabric and cable before unhooking to secure and properly control the fabric from ground level. If uninstalling in breezy conditions, choose the windy side of the fabric and tie these corners to the posts with the ropes with enough slack to allow for unhooking the fabric from the structure. These ropes are to prevent the shade from flying away in the breeze and to help prevent injury to ground personnel. Once the corners have been secured to the posts, unhook the fabric and cables from each corner.

On the side away from the wind, release the corners of the fabric and cable and have a person hold on to each rope. It may help to wrap the rope around a column to help hold it from getting caught in the wind. Fold the fabric back away from the hooks. Now it will be necessary to remove the cable clamps to allow the cable to be free from the structure and the turnbuckle. If the cable ends are frayed, wrap them with tape. It is usually not necessary nor is it recommended that the cable be removed from the canopy. With a person on each rope, starting at the windy side, gently pull the canopy down in between the framework of the structure. The side away from the wind can be guided with the ropes toward the persons pulling the canopy down.

It is important when reinstalling the canopy, that it is put back in its original orientation to the structure. Starting at the turnbuckle corner, the fabric and cable corners should be returned to their original positions.

GLIDE ELBOWS: For shade structures with Glide Elbows, remove the protective covers from the ends of the glide elbows. Then, using the proper wrench, turn the hex nuts on the end of the Glide Elbow to run the glide hooks to their top most position. Do not loosen the cable clamps, leave the cable intact. Attach 3/8" ropes to each corner of the fabric and cable before unhooking to secure and properly control the fabric from ground level. If uninstalling in breezy conditions, choose the windy side of the fabric and tie these corners to the posts with the ropes with enough slack to allow for unhooking the fabric from the structure. These ropes are to prevent the shade from flying away in the wind and to help prevent injury to ground personnel. Once the corners have been secured to the posts, unhook the fabric and cables. On the side away from the wind, release the corners of the fabric and cable and have a person hold on to each rope. Fold the fabric back away from the hooks. It is a good idea to put the Glide Elbow protective covers back in place. With Glide Elbow installations it is not necessary to loosen or remove the cable clamps nor to remove the cable from the canopy. If the cable ends are frayed, wrap them with tape.

When uninstalling the canopy, mark or identify the corner of origin in such a way that when reinstalling the canopy, it is put back in its original orientation to the structure. The fabric and cable corners should be returned to their original positions when reinstalling the canopy. The cable and fabric should tighten properly when the glide elbows are adjusted down into their tension positions.

SHADE SAILS WITH FANS: For shade sails equipped with fans, loosen the adjustable threaded rod several turns in order to put enough slack in the cable to allow the shackle pin to be removed (do not remove the pins until the fabric corners have been secured with ropes). Attach 3/8" or larger ropes to each corner of the fabric and fan before unhooking to secure and properly control the fabric from ground level. If uninstalling in breezy conditions, choose the windy side of the fabric and tie these corners to the posts with the ropes with enough slack to allow for unhooking the shackle from the structure. These ropes are to prevent the shade from flying away in the breeze and to help prevent injury to ground personnel. Once the corners have been secured to the posts, unhook the shackles and lower the fabric and cable to the ground.

REINSTALLING HINTS

Using the same rope technique, install from the windy side (if it is breezy) making sure to secure these ropes to the posts. Then, throw the remaining corner ropes over the structure and gently pull the canopy into position. The cables and fabric corners can now be fastened on the hooks (and cable guides if so equipped). Next reinstall the clamps if applicable and tightened the cable with the turnbuckle or the Glide Elbows. Do not attempt to install the canopy in strong or gusty winds.



Quote Id: 27314737

ALL PURCHASE ORDERS MUST BE MADE OUT TO (VENDOR):

Deere & Company
2000 John Deere Run
Cary, NC 27513
FED ID: 36-2382580
UEID: FNSWEDARMK53

ALL PURCHASE ORDERS MUST BE SENT TO DELIVERING DEALER:

P & K Equipment, Inc.
4385 W 520
Pryor, OK 74361
918-824-8541
pryor@pkequipment.com

Prepared For:

CITY OF PRYOR CREEK CEMETARY DEPARTMENT

Proposal For:

Delivering Dealer:

Justin Marshall

P & K Equipment, Inc.

4385 W 520

Pryor, OK 74361

pryor@pkequipment.com

Quote Prepared By:

Justin Marshall

jmarshall@pkequipment.com

Date: 24 August 2022

Offer Expires: 23 September 2022

Confidential



ALL PURCHASE ORDERS MUST BE MADE OUT TO (VENDOR):

Deere & Company
2000 John Deere Run
Cary, NC 27513
FED ID: 36-2382580
UEID: FNSWEDARMK53

ALL PURCHASE ORDERS MUST BE SENT TO DELIVERING DEALER:

P & K Equipment, Inc.
4385 W 520
Pryor, OK 74361
918-824-8541
pryor@pkequipment.com

Quote Summary

Prepared For:

CITY OF PRYOR CREEK CEMETARY DEPARTMENT
1614 NE 1ST ST
PRYOR, OK 74361
PRYORCITYPARKS@SBCGLOBAL.NET

Delivering Dealer:

P & K Equipment, Inc.
Justin Marshall
4385 W 520
Pryor, OK 74361
Phone: 918-824-8541
jmarshall@pkequipment.com

Thank you - we appreciate your business!

Prices listed include all applicable bonuses & rebates.

Quote ID: 27314737
Created On: 24 August 2022
Last Modified On: 24 August 2022
Expiration Date: 23 September 2022

WARRANTY INFORMATION: FOR NEW EQUIPMENT, PLEASE SEE THE MANUFACTURER'S WARRANTY STATEMENT FOR DETAILS. FOR USED EQUIPMENT, EQUIPMENT IS SOLD "AS-IS" WITH NO WARRANTIES EITHER EXPRESSED OR IMPLIED.

By signing below, the customer acknowledges that he/she has received a copy of the operator's manual for new equipment.

Equipment Summary	Selling Price	Qty	Extended
JOHN DEERE Z997R DIESEL NA	\$ 22,425.25 X	1 =	\$ 22,425.25
Contract: OK Mowers SW0190(PG 1L CG 22)			
Price Effective Date:			
Equipment Total			\$ 22,425.25

* Includes Fees and Non-contract items

Quote Summary

Equipment Total	\$ 22,425.25
Trade In	
SubTotal	\$ 22,425.25
Est. Service Agreement Tax	\$ 0.00
Total	\$ 22,425.25
Down Payment	(0.00)
Rental Applied	(0.00)
Balance Due	\$ 22,425.25

Salesperson : X _____

Accepted By : X _____



Selling Equipment



Quote Id: 27314737 Customer Name: CITY OF PRYOR CREEK CEMETARY DEPARTMENT

ALL PURCHASE ORDERS MUST BE MADE OUT TO (VENDOR):

Deere & Company
2000 John Deere Run
Cary, NC 27513
FED ID: 36-2382580
UEID: FNSWEDARMK53

ALL PURCHASE ORDERS MUST BE SENT TO DELIVERING DEALER:

P & K Equipment, Inc.
4385 W 520
Pryor, OK 74361
918-824-8541
pryor@pkequipment.com

JOHN DEERE Z997R DIESEL NA

Hours: 0

Stock Number: 1065718

Contract: OK Mowers SW0190(PG 1L CG 22)

Selling Price *

Price Effective Date:

\$ 22,425.25

* Price per item - includes Fees and Non-contract items

Code	Description	Qty	List Price	Discount%	Discount Amount	Contract Price	Extended Contract Price
091QTC	JOHN DEERE Z997R COMMERCIAL DIESEL ZTRAK W/60" DECK, PNEUMATIC	1	\$ 28,019.00	22.00	\$ 6,164.18	\$ 21,854.82	\$ 21,854.82
Standard Options - Per Unit							
001A	COUNTRY CODE-US / CANADA	1	\$ 0.00	22.00	\$ 0.00	\$ 0.00	\$ 0.00
1150	26X12X12 PNEUMATIC TURF TIRE	1	\$ 0.00	22.00	\$ 0.00	\$ 0.00	\$ 0.00
1504	Z997R 60"SD DSL MOWER	1	\$ 0.00	22.00	\$ 0.00	\$ 0.00	\$ 0.00
Standard Options Total			\$ 0.00		\$ 0.00	\$ 0.00	\$ 0.00
Dealer Attachments/Non-Contract/Open Market							
TCB10953	Mulch Kit (1524-mm (60-in.) 7-Iron, 7-Iron II and 7-Iron PRO)	1	\$ 380.91	22.00	\$ 83.80	\$ 297.11	\$ 297.11
997BR/18 0485	ALLIED CANOPY	1	\$ 350.41	22.00	\$ 77.09	\$ 273.32	\$ 273.32
Dealer Attachments Total			\$ 731.32		\$ 160.89	\$ 570.43	\$ 570.43
Value Added Services Total			\$ 0.00			\$ 0.00	\$ 0.00
Total Selling Price			\$ 28,750.32		\$ 6,325.07	\$ 22,425.25	\$ 22,425.25

Attachment 4: Personnel Requisition Form

To: Mayor

Date of Request: 9/6/22

Request is hereby made to fill the vacancy in:

Department: Fire

Title of Position: Firefighter

Date of Vacancy: (1) 3/31/23

This vacancy is the result of:

Termination of Services of Capt Gibbs Retirement
(last name of terminated employee)

Increased Work in Department 3 New Firefighters

Applicants should report for interview to Chief Young

[Signature]
Signature of Department Head

Signature of Mayor

- Approved
- Denied

To Chief Young, Asst. Chief Baumert, and the City of Pryor Creek.

It is with great sorrow and happiness that I am informing you of my retirement from the Pryor Creek Fire Department effective March 31, 2023. It has been a pleasure and an honor to have been a part of one of the finest fire departments in the state of Oklahoma. I have seen so many wonderful changes take place that has led up to the department we have today. I have had the opportunity to serve this department for thirty-five years and my time has come to step aside, to enjoy life with my family.

I will turn in my dates of leave as I will exhaust my vacation, holiday, and comp time available. I would also ask that I be compensated for all sick leave hours that have been unused per policy and procedure section, 13-4: Termination and Sick Leave.

Once again, I cannot express enough how fortunate I have been to have worked along side these men past and present that I call brothers. If within these years if I have made but a small impact on someone's life, whether it be co worker or civilian, it has been a career well worth the sacrifice.

Sincerely,

A handwritten signature in cursive script that reads "Captain Randy Gibbs". The signature is written in black ink and is positioned to the right of the typed name.

Captain Randy Gibbs

Pryor Fire



PROPOSAL

DATE	ESTIMATE NO.
6/23/2022	13737

6229 S. 107th E. Ave - Tulsa, OK 74133
 P - (918)438-8995 F - (918)437-8798

Account Name
Pryor Fire Department

Location Address
Pryor Fire Station 833 South Elliot Pryor, OK 74361

Customer Phone	Job #	APPT DATE	Account #	CONTRACT P.O.	REP
		6/23/2022			BCS

QTY	PART #	DESCRIPTION	TOTAL
1	Complete ...	<p>Openpath access control system with 3 controlled doors</p> <p>**Please note the 4 controlled door cost included below for your review</p> <p>We propose all material and labor for a complete Openpath access control system as described below:</p> <ul style="list-style-type: none"> 1 - 4door Openpath controller 3 - Openpath smart readers 3 - Electric door strikes 3 - Door contacts Wiring Programming <p>**To add the 4th door is only another \$715.00 for a total install cost of: \$9953.00</p>	9,238.00
1	Subscripti...	<p>Openpath is a cloud based access control system that carries a yearly subscription. This subscription keeps your system up to date with the latest security features as well as any system upgrades, additional system features and GUI updates. These are pushed down from the cloud automatically by Openpath to your system.</p> <p>The yearly subscription cost for this system will be \$720.00 and will be billed by Openpath</p>	
TOTAL			\$9,238.00

Barrett Staudt - System Sales Representative

Signature: _____

Librarian II - Administrative & Systems Librarian

Overview

Description:

A full-time, non-exempt position requiring a wide familiarity with Library and City Hall procedures as well as a working knowledge of the Library's computer systems. Must have skills to organize and maintain library records according to City retention policy, keep computers up-to-date and operational, and help with event programming and implementation.

Examples of work performed:

- Obtains and reports all Library statistics
- Prepares all reports for Library Board meeting
- Records minutes at Library Board meetings
- Receives all bills and processes them for payment
- Maintains the documentation of the Material Safety Data Sheets
- Collects daily receipts and balances accounts
- Deposits all receipts at City Hall
- Keeps account of petty cash
- Assists Library Director in monitoring the Library's budget
- Orders, receives, and keeps inventory of all supplies
- Maintains office photocopier and other office equipment
- Maintains inventory of fixed assets
- Manages organization and storage of all Library records
- With the Library Director, installs and maintains library computers, including hardware and software maintenance, updates, and troubleshooting
- With the Adult Services Librarian, plans and implements programming, events, classes, and activities
- Creates promotional materials and updates Library social media and/or website as needed
- Assists at public service desks as needed
- Shelves materials as needed

Requirements for position:

- Bachelor's degree or experience commensurate with the position
- Ability to obtain Oklahoma Department of Libraries certification within two years
- Self-directed and able to learn new processes quickly
- Skill in application and interpretation of library policies and procedures
- Strong communication and public relation skills, both oral and written
- Must be able to maintain a professional demeanor under pressure
- High clerical aptitude, detail oriented, and excellent keyboard skills
- In-depth knowledge of basic computer programs and the internet
- Excellent grammar and telephone manners
- Strong organizational and problem solving skills

Librarian II - Adult Services Librarian

Overview

Description:

A full-time, non-exempt position requiring a wide familiarity with Library procedures and the Library collection, especially the adult collections. Must have skills to work closely with the public to build and maintain essential Library services.

Examples of work performed:

- Acts as Library Administrator in the absence of the Library Director
- Acts as Library representative to professional organizations and community groups as needed
- With Administrative Librarian, plans and implements programming, classes, events, and activities
- Creates promotional materials and updates Library social media and website
- Supervises part-time Library Assistant staff assigned to Adult Services area
- Supervises and performs circulation tasks such as checking materials in and out, creating new patron accounts, placing holds, etc.
- With the Collection Development Librarian, selects and deselects materials for adults
- Develops and supervises Adult Literacy and English Language Learning (ELL) services for Library patrons
- Creates displays to highlight collections or services
- Keeps departmental records and statistics
- Develops departmental goals and helps implement them
- Keeps abreast of professional developments
- Instructs patrons in basic library use
- Helps patrons find information in person, on the telephone, and via email
- Helps patrons locate materials in the department or library
- Provides readers advisory services
- Assists patrons with computer and printer use as needed

Requirements for position:

- Bachelor's degree or experience commensurate with the position
- Ability to obtain Oklahoma Department of Libraries certification within two years
- Self-directed and able to learn new processes quickly
- Skill in application and interpretation of library policies and procedures
- Strong communication and public relation skills, both oral and written
- Must be able to maintain a professional demeanor under pressure
- High clerical aptitude, detail oriented, and excellent keyboard skills
- In-depth knowledge of basic computer programs and the internet
- Excellent grammar and telephone manners
- Strong organizational and problem solving skills

Librarian II - Collection Development

Overview

Description:

A full-time, non-exempt position requiring a wide familiarity with Library policies and procedure as well as the Library collection. Must have skills to work closely with the public and various Library vendors to build and maintain essential Library services.

Examples of work performed:

- Maintains and curates the Library's collection through the selection, deselection, and processing of materials
- Includes appropriate Library staff in selection, deselection, and processing of materials to minimize potential for bias in the Library collection
- Stays abreast of book reviews, publishing trends, and local and general interests in order to identify materials to meet patron needs, enrich the Library's collections, and correct deficiencies
- Allocates funds to meet collection development goals
- Maintains the bibliographic database; performs original, contributed, and copy cataloging for Library materials in all formats
- Supervises part-time Library Assistant staff assigned to the Computer Lab
- Assists patrons with computers and printers/copiers as needed
- Enforces library policies
- Attends professional meetings and training workshops
- Keeps departmental records and statistics
- Develops departmental goals and helps implement them
- Plans and implements programming, events, classes, and activities as needed

Requirements for position:

- Bachelor's degree or experience commensurate with the position
- Ability to obtain Oklahoma Department of Libraries certification within two years
- Self-directed and able to learn new processes quickly
- Skill in application and interpretation of library policies and procedures
- Strong communication and public relation skills, both oral and written
- Must be able to maintain a professional demeanor under pressure
- High clerical aptitude, detail oriented, and excellent keyboard skills
- In-depth knowledge of basic computer programs and the internet
- Excellent grammar and telephone manners
- Strong organizational and problem solving skills

Librarian II - Genealogy & Research Librarian

Overview

Description:

A full-time, non-exempt position requiring a wide familiarity with Library policies and procedures, genealogical and general research procedures, and the Library's local history collection.

Examples of work performed:

- Maintains and curates the Library's genealogical and local history collection through the selection, deselection, and processing of materials
- Manages and curates departmental equipment
- With the Youth Services Librarian, manages and curates Makerspace equipment
- With the Youth Services Librarian, plans and implements activities in the Makerspace
- With the Collection Development Librarian, selects and deselects materials for adults
- Supervises part-time Library Assistant staff assigned to the Local History/Genealogy area
- With the Library Director, selects and maintains online resources and other subscriptions
- Assist patrons with online resource use
- Researches, orders, returns, and manages all Inter-Library Loan items
- Oversees test proctoring
- Assists patrons in finding information in person, on the phone, and via email
- Instructs patrons in basic library use
- Enforces library policies
- Attends professional meetings and training workshops
- Keeps abreast of professional developments
- Takes inventory of genealogy and local history materials
- Catalogs and manages archived materials and obituaries
- Manages newspapers and microfilm
- Archives and preserves materials as appropriate

Requirements for position:

- Bachelor's degree or experience commensurate with the position
- Ability to obtain Oklahoma Department of Libraries certification within two years
- Aptitude for working with the public
- Self-directed and able to learn new processes quickly
- Skill in application and interpretation of library policies and procedures
- Strong communication and public relation skills, both oral and written
- Must be able to maintain a professional demeanor under pressure
- High clerical aptitude, detail oriented and excellent keyboard skills
- In-depth knowledge of basic computer programs and the internet
- Excellent grammar and telephone manners
- Strong organizational and problem solving skills

Library Assistant

Overview

Description:

A part-time position assisting in all aspects of library service to the public. A Library Assistant may be asked to specialize in a particular area of Library service such as Youth Services, Adult Services, Computer Lab, Genealogy and Local History, etc. but will be expected to be able to assist in all areas of the Library.

Examples of work performed:

- Checks materials in and out
- Shelves books
- Assists in the processing of materials
- Handles patron account transactions
- Assists patrons with general, directional, and reference questions
- Assists patrons with general computer questions
- Assists with programming, events, classes, and activities as needed
- Assists full-time staff as needed

Requirements for position:

- High school diploma, equivalent, or ability to obtain diploma or equivalent within 2 years
- Self-directed and able to learn new processes quickly
- Good communication skills, both spoken and written
- Must be able to maintain a professional demeanor under pressure
- Working knowledge of basic computer programs and the internet
- Good grammar and telephone manners
- Excellent customer service skills
- Strong organizational and problem solving skills

City Department Head - Library Director

Overview

Description:

A full-time, exempt position requiring a wide familiarity with Library philosophies, procedures, and trends. Must have skills to work closely with the public as well as City officials and civic leaders to ensure the Library is a vibrant, active, and essential resource that the community is proud to support.

Examples of work performed:

- Drafts and recommends Library policy to the Library Board and City Council
- Plans for the implementation of Library goals and objectives
- Evaluates and oversees Library programs and services
- Directs the development and maintenance of the Library's collection
- Directs the development, repair, and maintenance of the Library's building
- Directs personnel actions such as hiring, termination, evaluation, etc.
- Supervises Library staff directly or through appropriate delegation to create a harmonious team environment
- Supervises volunteer program, including recruitment, training, scheduling, and evaluating
- With the Library Board President, creates and distributes Library Board agendas and minutes
- Prepares the annual Library budget and presents and defends budget requests before the Library Board and City Council
- Directs and controls the expenditure of Library fund allocations within the constraints of approved budget
- Prepares grant requests and administers grant funds awarded by state and federal agencies and nonprofit foundations
- Prepares regular narrative and statistical reports
- Stays informed on issues related to library services and management by attending conferences, workshops, and meetings and reading professional literature
- Prepares and files annual report with the Oklahoma Department of Libraries
- Represents the Library on regional and state committees and serves as the City's authority on library issues
- Assists with direct patron services as needed

Requirements for position:

- Master's degree in Library Science from an ALA accredited program with a minimum of 3 years supervisory experience
- Ability to obtain Oklahoma Department of Libraries certification within two years
- Commitment to the principles of unrestricted access to information
- Self-directed and able to learn new processes quickly
- Skill in application and interpretation of library policies and procedures
- Strong communication and public relation skills, both oral and written
- Must be able to maintain a professional demeanor under pressure
- In-depth knowledge of basic computer programs and the internet
- Strong organizational and problem solving skills

Librarian II - Youth Services Librarian

Overview

Description:

A full-time, non-exempt position requiring a wide familiarity with library procedures and the library collection, especially the children and teen collections. Must have skills to organize and conduct children and teen services, including programs, in a professional manner.

Examples of work performed:

- With the Collection Development Librarian, selects and deselects materials for the Youth Services Department
- Plans and conducts early literacy classes such as storytime
- Plans and conducts age appropriate programs, events, classes, and activities for children and teens
- Plans and conducts age appropriate summer reading programs, events, classes, and activities for children and teens
- Provides readers advisory services
- Provides outreach services to the community
- Supervises part-time Library Assistant staff assigned to Youth Services
- Maintains order in the department
- Helps patrons find information in person, on the telephone, and via email
- Helps patrons locate materials in the department or library
- Assists patrons with computers in the department
- Instructs patrons in basic library use
- Enforces library policies
- Attends professional meetings and training workshops
- Keeps abreast of professional developments
- Keeps departmental records and statistics
- Develops departmental goals and helps implement them
- Creates promotional material as needed

Requirements for position:

- Bachelor's degree or experience commensurate with the position
- Ability to obtain Oklahoma Department of Libraries certification within two years
- Aptitude for working with the public, especially children, teens, and their caregivers
- In-depth knowledge of children's and teen's literature and an interest in a variety of subjects
- Self-directed and able to learn new processes quickly
- Skill in application and interpretation of library policies and procedures
- Strong communication and public relation skills, both oral and written
- Ability to maintain a professional demeanor under pressure
- In-depth knowledge of basic computer programs and the internet
- Excellent grammar and telephone manners
- Strong organizational and problem solving skills